

STA-RITE® D Series

Self-Priming Centrifugal Pumps

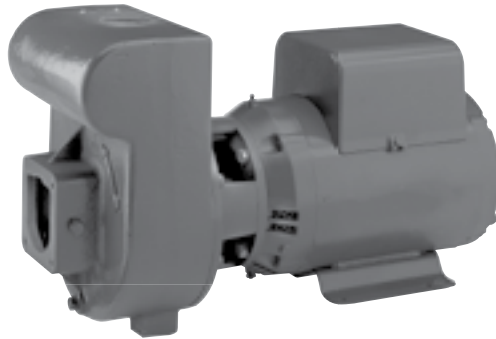

3 and 5 HP

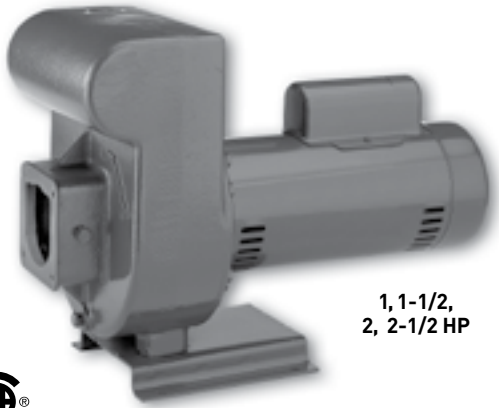

1, 1-1/2,
2, 2-1/2 HP



Order suction flange with flapper check separately.

SPECIFICATIONS

Body and Base: Close-grained cast iron

Impeller: Noryl® on 1 through 2-1/2 HP, bronze on 3 and 5 HP

Diffuser: Cast iron

Shaft: 1 through 2-1/2 HP: 416 stainless steel; 3 and 5 HP: Carbon steel inside removable shaft sleeve of stainless steel.

Max Inlet Pressure: 20 PSI

Max Discharge Pressure: 100 PSI

Max Liquid Temperature: 60°C/140°F

Max Ambient Air Temperature: 40°C/104°F

FEATURES

1 through 5 HP: Both high head and medium head models offer heavy-duty motors, easy service design, and air volume control tapping.

Drain Port: Provided for easy winterizing.

Medium Head Models: Deliver up to 115' of head with capacities to 159 GPM.

High Head Models: Deliver up to 138' of head with capacities to 162 GPM.

Easy Serviceability: Normal wearing parts are easily accessible for service and replacement, without disturbing piping or mounting.

Heavy-Duty Motors: Designed for continuous operation. Capacitor start, will not cause electrical interference with TV or other appliances. Nationally known motors have ball bearing, stainless steel shaft. For single- and three-phase operation, 3450 RPM.

Some of the fastest priming pumps on the market. Available in high head or medium head series. Features mechanical seals, easy service design, heavy-duty motors, rugged construction. Available in 1 through 5 HP.

Optional 6" and 8" Trap Packages are available.

APPLICATIONS

Lawn Sprinkling...operate from 1 to 30 or more heads. Can be safely operated by timer or other automatic device.

Contractors...for dewatering excavation, jetting, water transfer and supply operations.

Agriculture...seed bed and plot irrigation, stock watering, fire protection.

Industrial...sump drainage, fire protection, marine pumping, liquid transfer and supply operations.

Noryl® is a registered trademark of General Electric Co.
All other brand or product names are trademarks or registered trademarks of Pentair Ltd.

STA-RITE® D Series

Self-Priming Centrifugal Pumps

ORDERING INFORMATION

HIGH HEAD

Catalog Number	HP	Pipe Tapping Sizes			Motor Voltage	Phase	Approx. Wt. Lbs.
		Suction Flanges*	Top Discharge	Side Discharge**			
DHE	1	PKG 53	1-1/2"	1-1/2"	115/230	1	65
DHE3	1	PKG 53	1-1/2"	1-1/2"	208-230/460	3	65
DHF	1-1/2	PKG 53	1-1/2"	1-1/2"	115/230	1	72
DHF3	1-1/2	PKG 53	1-1/2"	1-1/2"	208-230/460	3	72
DHG	2	PKG 72	2"	-	115/230	1	113
DHG3	2	PKG 72	2"	-	208-230/460	3	113
DHHG	2-1/2	PKG 72	2"	-	115/230	1	120
DHHG3	2-1/2	PKG 72	2"	-	208-230/460	3	120
DH2H	3	PKG 53	2"	-	200	1	144
DHH	3	PKG 53	1-1/2"	-	230	1	144
DH2H3	3	PKG 53	2"	-	200	3	144
DHH3	3	PKG 53	1-1/2"	-	208-230/460	3	144
DH2J	5	PKG 72	2"	-	200	1	184
DHJ	5	PKG 72	2"	-	230	1	184
DH2J3	5	PKG 72	2"	-	200	3	184
DHJ3	5	PKG 72	2"	-	208-230/460	3	184

MEDIUM HEAD

DMG	2	PKG 53	1-1/2"	1-1/2"	115/230	1	86
DMG3	2	PKG 53	1-1/2"	1-1/2"	208-230/460	3	86
DMMG	2-1/2	PKG 72	2"	1-1/2"	115/230	1	93
DMMG3	2-1/2	PKG 72	2"	1-1/2"	208-230/460	3	93
DM2H	3	PKG 72	2-1/2"	-	200	1	127
DMH	3	PKG 72	2"	-	230	1	137
DM2H3	3	PKG 72	2-1/2"	-	200	3	137
DMH3	3	PKG 72	2"	-	208-230/460	3	137
DM2J	5	PKG 73	3"	-	200	3	184
DMJ	5	PKG 73	2-1/2"	-	230	1	184
DM2J3	5	PKG 73	3"	-	200	3	184
DMJ3	5	PKG 73	2-1/2"	-	230/460	3	184

*Suction flanges must be ordered separately. See chart below.

**Pumps with Side discharge Tap of 1-1/2" are shipped with a 1-1/2" Square Head Pipe Plug in tap.

SUCTION FLANGES (Order separately – required for suction tap sizes)

Package 52 -	Package 53 -	Package 72 -	Package 73 -
1-1/2"	2"	2-1/2"	3"



PKG 52
1-1/2"

PKG 53
2" NPT



PKG 72
2-1/2"

PKG 73
3" NPT

STA-RITE® D Series

Self-Priming Centrifugal Pumps

6" AND 8" TRAP PACKAGES

Catalog Number	Description	Suction Port Size	Approx. Wt. Lbs.
PKG 51	6" Cast Iron Trap with Basket (For C, CC, and D Series Pumps)	2" NPT	20
PKG 76	Cast Iron Flange for Remote Installation	3" NPT	4
PKG 98	8" Cast Iron Trap with Basket (For C, CC, and D Series Pumps)	3" NPT	40

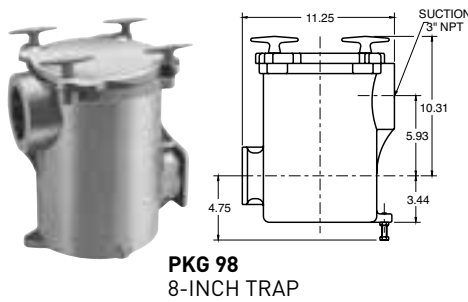
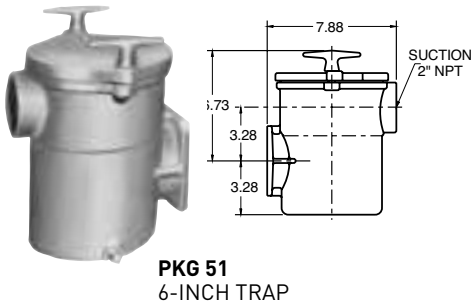

SUCTION TRAP PSI LOSS CURVE

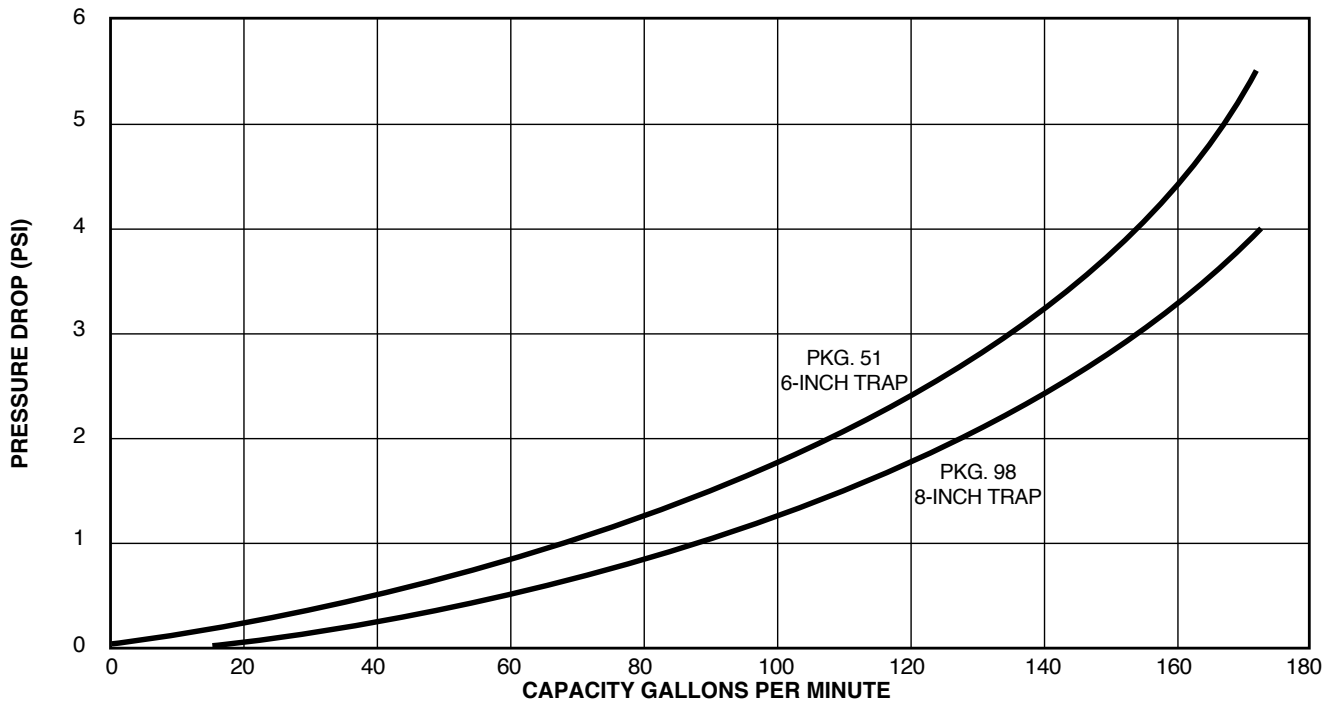

STA-RITE® D Series

Self-Priming Centrifugal Pumps

PUMP PERFORMANCE: HIGH HEAD

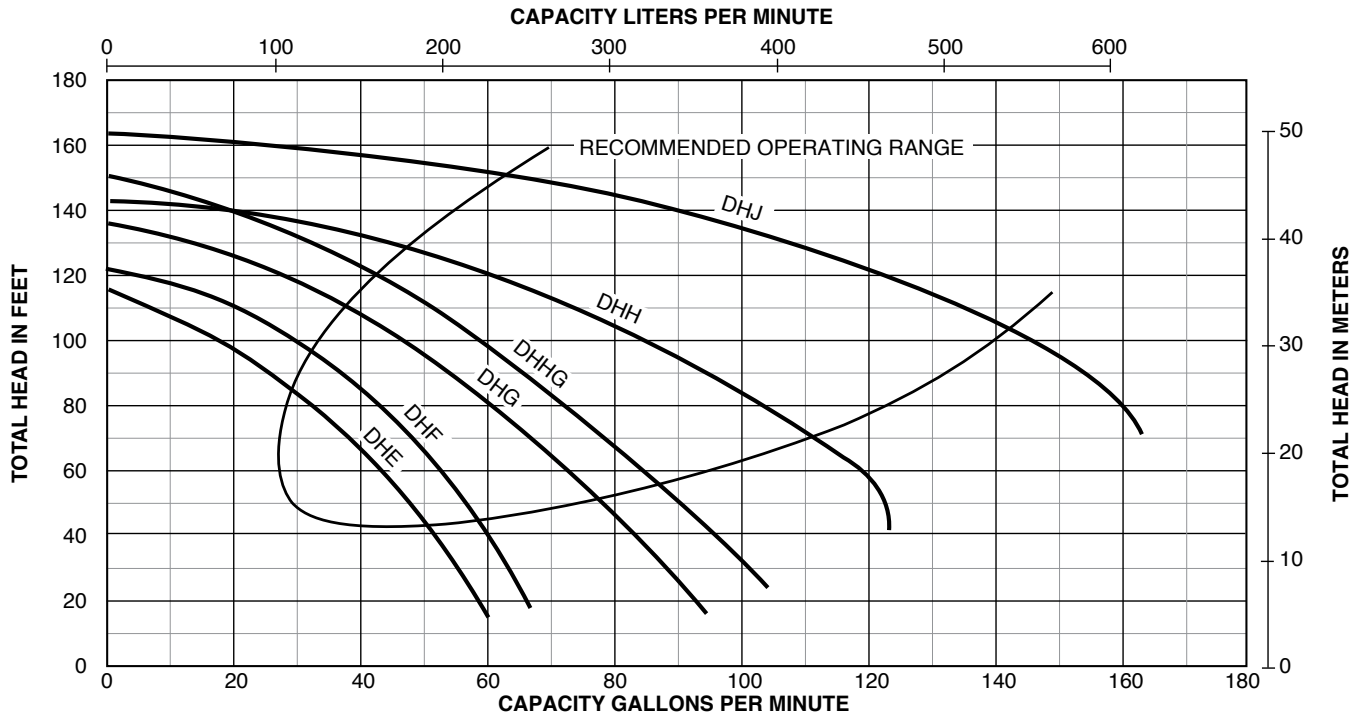

PUMP PERFORMANCE (CAPACITY IN GALLONS PER MINUTE)

HIGH HEAD

Cat. No.	HP	Discharge		Suction Lift in Feet				
		PSI	Feet Head	5'	10'	15'	20'	25'
DHE	1	20	46.2	46	43	41	40	38
		30	69.3	35	32	29	25	21
		40	92.4	19	15	-	-	-
		50	115.5	-	-	-	-	-
		60	138.6	-	-	-	-	-
DHF	1-1/2	20	46.2	55	53	51	49	48
		30	69.3	45	42	39	36	32
		40	92.4	31	27	22	15	-
		50	115.5	-	-	-	-	-
		60	138.6	-	-	-	-	-
DHG	2	20	46.2	77	74	71	68	65
		30	69.3	63	60	56	53	49
		40	92.4	48	44	40	36	30
		50	115.5	30	20	13	-	-
		60	138.6	-	-	-	-	-

PUMP PERFORMANCE (CAPACITY IN GALLONS PER MINUTE)

HIGH HEAD

Cat. No.	HP	Discharge		Suction Lift in Feet				
		PSI	Feet Head	5'	10'	15'	20'	25'
DHHG	2-1/2	20	46.2	89	85	82	80	76
		30	69.3	75	72	68	64	60
		40	92.4	60	57	51	49	42
		50	115.5	42	37	31	25	20
		60	138.6	14	-	-	-	-
DHH	3	20	46.2	-	-	-	112	109
		30	69.3	109	103	98	92	89
		40	92.4	90	75	74	69	62
		50	115.5	62	51	42	32	20
		60	138.6	-	-	-	-	-
DHJ	5	20	46.2	-	-	-	-	-
		30	69.3	-	-	-	-	-
		40	92.4	146	141	136	130	122
		50	115.5	122	114	105	99	85
		60	138.6	81	70	50	30	-

STA-RITE® D Series

Self-Priming Centrifugal Pumps

PUMP PERFORMANCE: MEDIUM HEAD

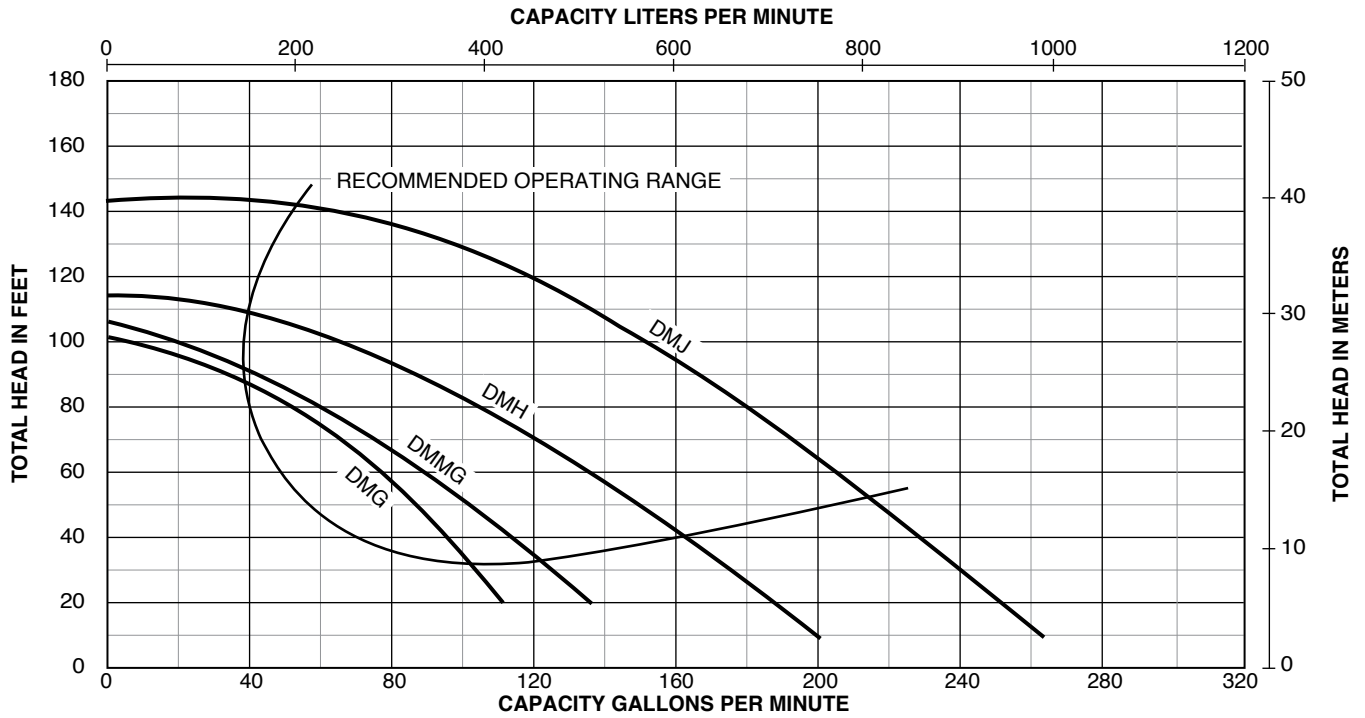

PUMP PERFORMANCE (CAPACITY IN GALLONS PER MINUTE)

MEDIUM HEAD

Model	Capacity (GPM)	Total Head (Feet)							
		20	30	40	50	60	70	80	
DMG	2	20	46.2	84	79	74	69	63	
		30	69.3	60	53	46	35	20	
		40	92.4	22	-	-	-	-	-
		50	115.5	-	-	-	-	-	-
DMMG	2-1/2	20	46.2	103	96	90	80	70	
		30	69.3	70	60	50	46	30	
		40	92.4	30	18	5	-	-	
		50	115.5	-	-	-	-	-	
DMH	3	20	46.2	149	140	136	124	119	
		30	69.3	116	108	99	85	76	
		40	92.4	75	65	51	26	-	
		50	115.5	-	-	-	-	-	
DMJ	5	20	46.2	214	209	202	194	182	
		30	69.3	185	179	172	165	158	
		40	92.4	153	146	139	130	120	
		50	115.5	119	107	95	80	50	

STA-RITE® D Series

Self-priming centrifugal pumps

OUTLINE DIMENSIONS

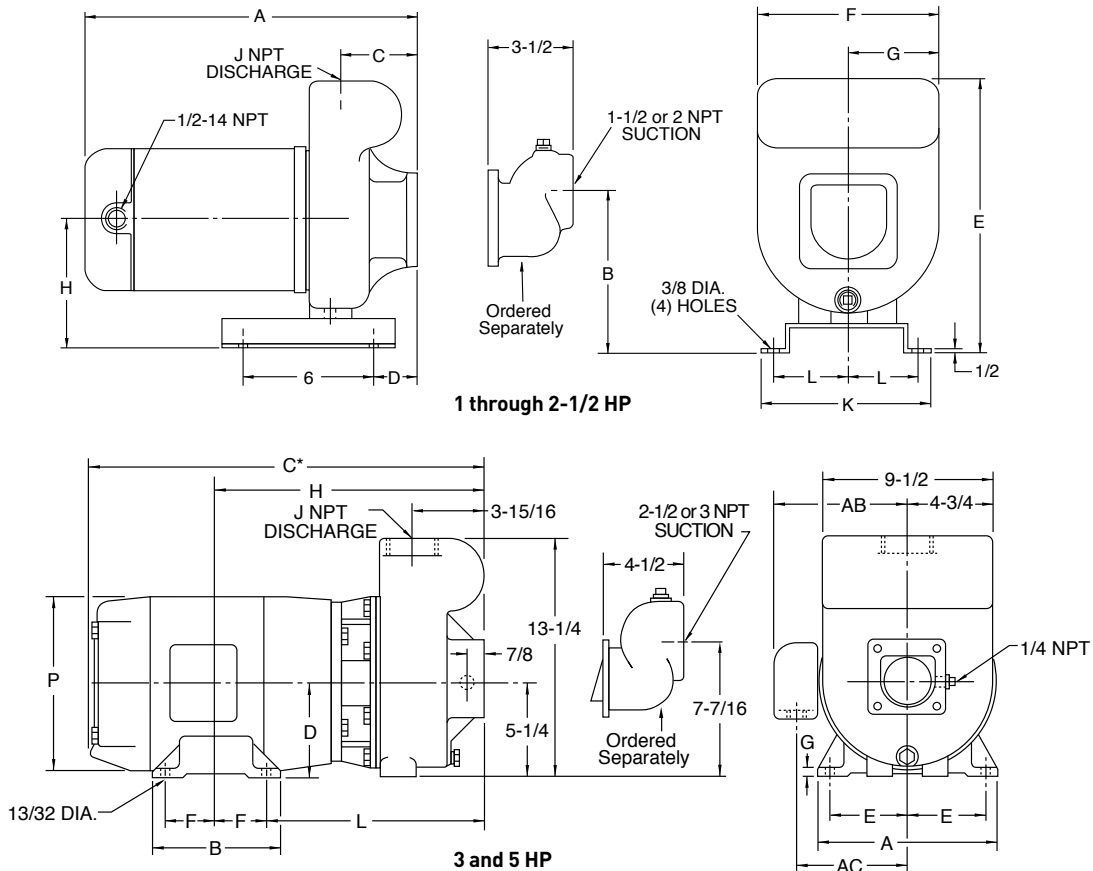

Dimensions (in inches) are for estimating purposes only.

DIMENSIONS IN INCHES: 1 THROUGH 2-1/2 HP

Catalog Number	HP	A	B	C	D	E	F	G	H	J	K	L
DHE**	1	14-13/16	7-1/16	3-1/2	4	11-7/8	7-7/8	3-15/16	5-13/16	1-1/2	7-1/2	3-3/8
DHF**	1-1/2	15-11/16	7-1/16	3-1/2	4	11-7/8	7-7/8	3-15/16	5-13/16	1-1/2	7-1/2	3-3/8
DHG	2	17-11/16	7-13/16	3-15/16	3-13/16	14-3/8	9-1/2	4-3/4	6-9/16	2	7-1/2	3-3/8
DHHG	2-1/2	18-11/16	7-13/16	3-15/16	3-13/16	14-3/8	9-1/2	4-3/4	6-9/16	2	7-1/2	3-3/8
DMG**	2	16-15/16	7-1/16	3-1/2	4	11-7/8	7-7/8	3-15/16	5-13/16	1-1/2	7-1/2	3-3/8
DMMG**	2-1/2	17-15/16	7-1/16	3-1/2	4	11-7/8	7-7/8	3-15/16	5-13/16	2	7-1/2	3-3/8

DIMENSIONS IN INCHES: 3 AND 5 HP

Catalog Number	HP	A	B	C*	D	E	F	G	H	J	L	P	AB	AC
DHH	3	9	6	20-3/4	4-1/2	3-3/4	2-1/4	1/2	15	1 - 1/2"	12-3/4	9-3/4	8-1/8	6-1/2
DHJ	5	9	7	21-3/4	4-1/2	3-3/4	2-3/4	1/2	15-1/2	2"	12-3/4	9-3/4	9	7
DMH	3	9	6	20-3/4	4-1/2	3-3/4	2-1/4	1/2	15	2"	12-3/4	9-3/4	8-1/8	6-1/2
DMJ	5	9	7	21-3/4	4-1/2	3-3/4	2-3/4	1/2	15-1/2	2 - 1/2"	12-3/4	9-3/4	9	7

*Overall length (C) is shown for single-phase motors. Three-phase motors are slightly smaller. Dimensions are for estimating purposes only.

**Pump body has additional built in 1-1/2" NPT side discharge tap.



293 WRIGHT STREET, DELAVAN, WI 53115 WWW.STA-RITE.COM PH: 888-782-7483 ORDERS FAX: 800-426-9446

Because we are continuously improving our products and services, Pentair reserves the right to change specifications without prior notice.