

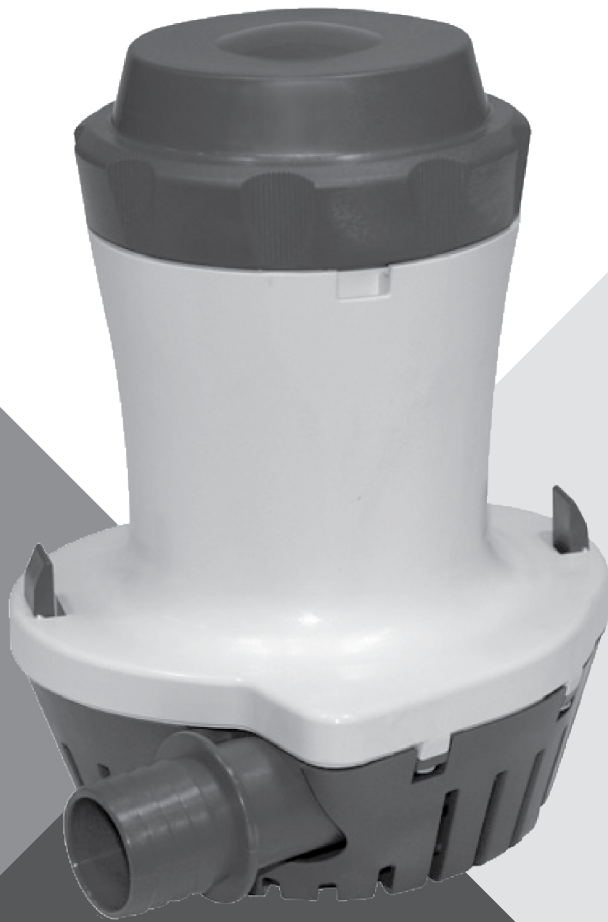

358 BILGE PUMP



INSTALLATION AND OPERATION MANUAL

pentair.com

©2021 Pentair. All Rights Reserved.

911-742 (09/15/21)

TABLE OF CONTENTS

Safety 3

Installation & Operation 4

Troubleshooting 7

SAFETY

SAFETY SYMBOLS

 This is the safety alert symbol. When you see this symbol on your pump or in this manual, look for one of the following signal words and be alert to the potential for personal injury:

 **DANGER** warns about hazards that will cause serious personal injury, a minimum diameter of 24" is recommended use serious personal injury, death or major property damage if ignored.

 **WARNING** warns about hazards that can cause serious personal injury, death or major property damage if ignored. Warns about hazards that will or can cause minor personal injury or property damage if ignored.

The word **NOTICE** indicates special instructions that are important but not related to hazards.

CALIFORNIA PROPOSITION 65 WARNING:

This product and related accessories contain chemicals known to the State of California to cause cancer, birth defects or other reproductive harm.

GENERAL CAUTION STATEMENTS

- ◆  **WARNING** Do not pump oil, diesel fuel, gasoline or other flammable liquids with this pump.
- ◆ This pump does not prevent the discharge of oil or other chemicals into the water. Please take appropriate measures to prevent discharging oil or other chemicals and safeguard the environment.
- ◆ Always disconnect power before servicing pump.
- ◆ Always use fuse size specified in specifications.
- ◆ These bilge pumps are designed to evacuate standing bilge water only. These pumps may not prevent boat sinkage due to storms, rough weather, unsafe boating, improper installation procedures or hull damage.

INSTALLATION AND OPERATION

ADVANCED BILGE FEATURES

- ◆ Anti-Airlock
- ◆ Tough Nylon Housing
- ◆ Tinned 6' Wire Assembly
- ◆ Water Cooled Motor
- ◆ Submersible
- ◆ Ignition Protected
- ◆ ISO 8846, ABYC, NMMA Type
- ◆ Accepted, CE

MOUNTING

- ◆ Locate the pump in the deepest position in the bilge. Keep away from high heat source.
- ◆ Mount quick disconnect bracket to bulkhead or stringer with #10 S.S. screws. Do not drive screws through hull.
- ◆ Route smooth I.D. discharge tubing to a thru-hull fitting well above the water line. Avoid any sagging or loops in the tubing. Tubing must go up from the pump to the thru-hull fitting.

ELECTRICAL

Use 16GA wire for all circuits. If installation is over 20 feet, use 14GA wire. Brown pump wire must be hooked to positive power for maximum flow. Wire is tinned to prevent corrosion.

PANEL SWITCH

Attach all wires to UL Marine approved duty switch with auto-off-manual, rated at or above 15 amps.

FUSE

Install a fuse per pump label specifications.

CONNECTIONS

Wire connections should be made above the highest possible water level. Seal wire connections to prevent corrosion and electrolysis.

OPERATION

Do not run pump dry. Always test pump and switch before leaving dock.

MANUAL MODE

To turn pump on, turn manual power switch on. If pump does not turn on, turn switch off, check power, fuses, connections, wires. Retry. If pump does not turn on, check pump motor.

FLOW GPH [LPH]

TECHNICAL DATA

Name	Voltage	Model #	0' [0m]	3' [1m]	6' [2m]	Max. Head ft. [m]	Max. Amps	Fuse	Outlet Port	Dims.
1500	12 V*	358-000-00	1800 [6813]	1700 [6434]	1600 [6056]	14 [4.27]	8	10	1-1/8"	7-1/4" x 6"
2000	12V*	358-010-00	2200 [8327]	2000 [7570]	1900 [7191]	18 [5.5]	10	15	1-1/8"	7-1/4" x 6"
1500	24V	358-100-00	1800 [6813]	1700 [6434]	1600 [6056]	14 [4.27]	4	6	1-1/8"	7-1/4" x 6"
2000	24V	358-110-00	2200 [8327]	2000 [7570]	1900 [7191]	18 [5.5]	5	6	1-1/8"	7-1/4" x 6"

*Specifications given at design voltage 13.6 VDC per ABYC recommendations.

Pump Power leads: 6 ft. [1.8 M] #16 tinned stranded copper wire to minimize corrosion. Positive (+) brown; Ground (-) black.

Temperature limits: 33°F—140°F [0°C—60°C]. All models rated for continuous duty.

Approvals: Ignition Protected, ISO 8846, ABYC, NMMA Type Accepted, CE.

INSTALLATION AND OPERATION

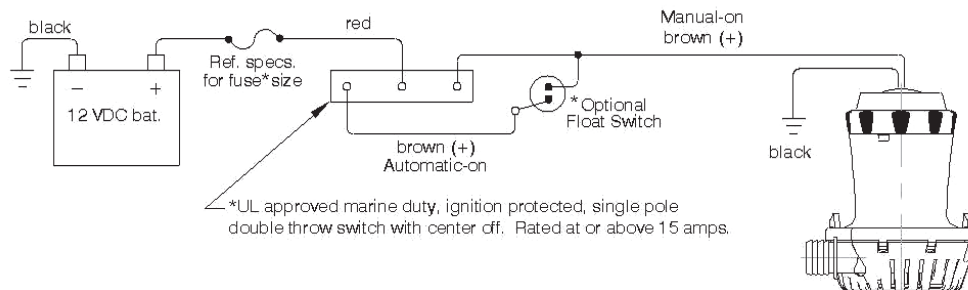
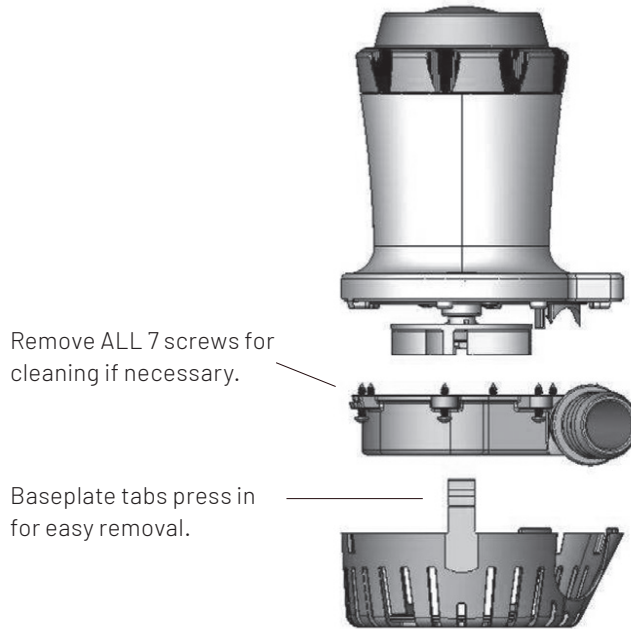
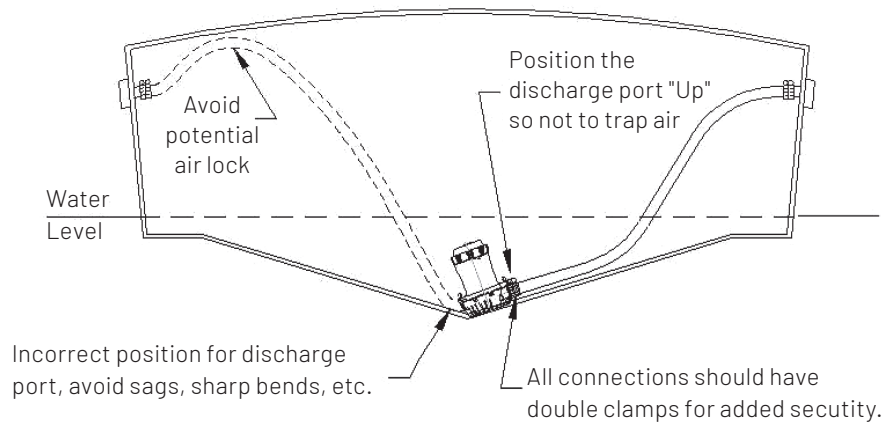

NOTE: Typical circuit only, consult boat wiring diagram.

PAGE LEFT BLANK INTENTIONALLY

TROUBLESHOOTING

CONDITION	PROBABLE CAUSE
NO WATER PUMPED / PUMP NOT RUNNING	<ul style="list-style-type: none">◆ Blown fuse.◆ Wire connections.◆ Impeller or float switch plugged with debris.
REDUCTION IN WATER FLOW	<ul style="list-style-type: none">◆ Impeller/screen plugged with debris.◆ Pinch/clogged discharge tubing.◆ Discharge tubing sagging below pump causing air lock.◆ Tubing must go up from pump to thru-hull fitting.◆ Low voltage to pump; check battery/wire connections.
LOW FLOW	<ul style="list-style-type: none">◆ Polarity reversed; check wiring.◆ Use only smooth bore (I.D.) discharge tubing.◆ Is thru-hull fitting I.D. smaller than pump discharge port?



SHURFLO EUROPE | MIDDLE EAST | AFRICA | pentair.com

All indicated Pentair trademarks and logos are property of Pentair. Third party registered and unregistered trademarks and logos are the property of their respective owners. Because we are continuously improving our products and services, Pentair reserves the right to change specifications without prior notice. Pentair is an equal opportunity employer.

©2021 Pentair. All Rights Reserved.

911-742(09/15/2021)