

An aerial photograph of a white motorboat with a white canvas cover on the deck, moving through clear turquoise water. The boat is leaving a white wake behind it. The background is a deep blue sea with some white foam from a wave in the distance. The entire image is overlaid with a semi-transparent diamond-shaped grid pattern.

# SHURFLO<sup>®</sup>

# MARINE PUMPS, FILTRATION AND ACCESSORIES

---

MARINE PRODUCT GUIDE - INTERNATIONAL



**SHURFLO®**

THE INDUSTRY'S LEADING  
MARINE PLUMBING SUPPLIER  
FOR MORE THAN 40 YEARS.



# MARINE PRODUCTS

## TABLE OF CONTENTS

- 1 MARINE PLUMBING SYSTEM**
- 3 FRESH WATER PUMPS**
- 5 WASHDOWN PUMPS**
- 7 LIVEWELL PUMPS**
- 8 BILGE PUMPS**
- 9 GENERAL PURPOSE PUMPS**
- 10 MARINE BLOWERS IN-LINE & MACERATOR PUMPS**
- 11 ACCESSORIES**
- 12 WATER FILTRATION**
- 13 PUMP FITTINGS**
- 14 PUMP REPAIR & REBUILD KITS**
- 20 INSTALLATION GUIDELINES**

# SHURFLO® MARINE PLUMBING SYSTEM

ALL MAJOR PLUMBING COMPONENTS

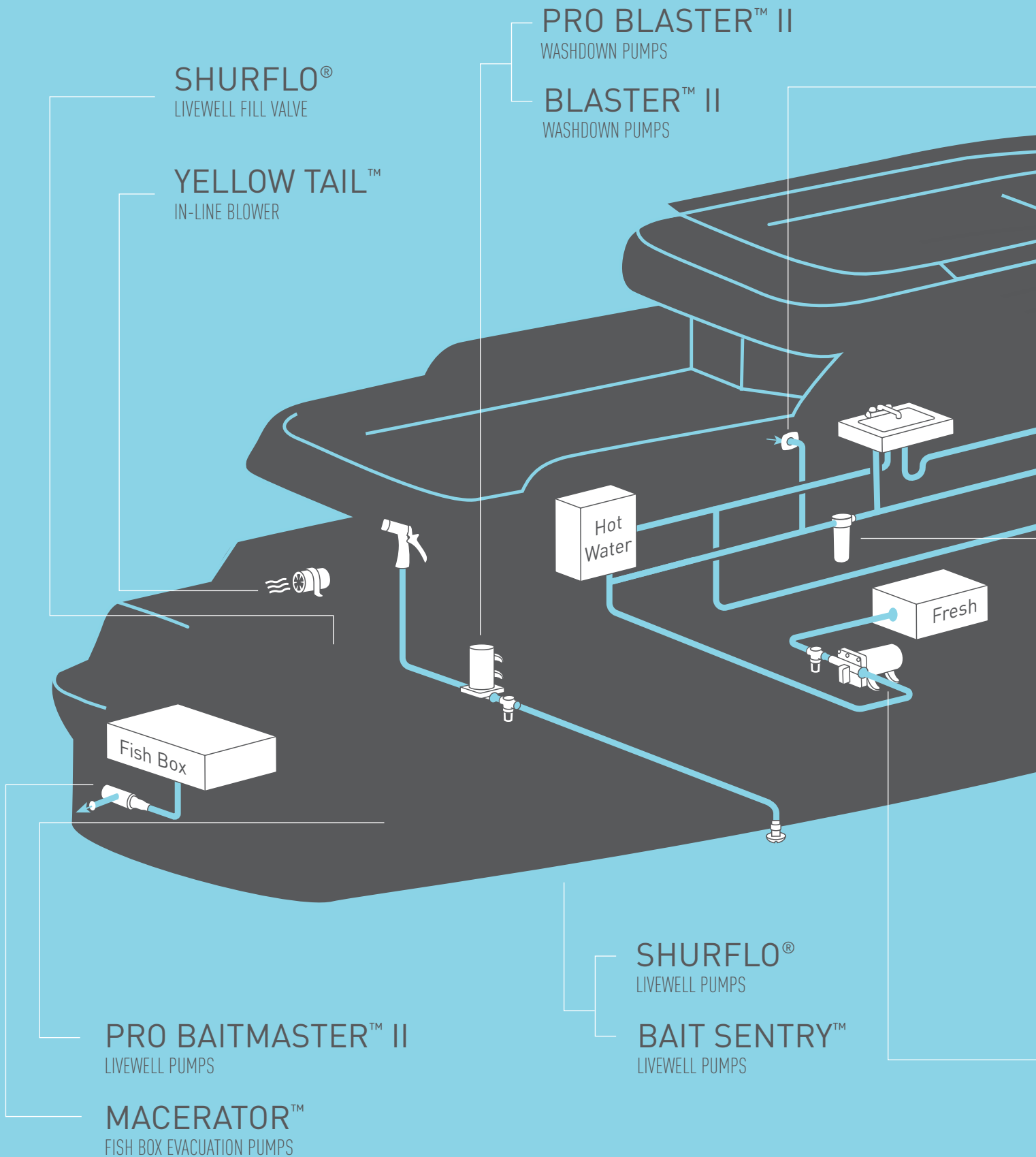

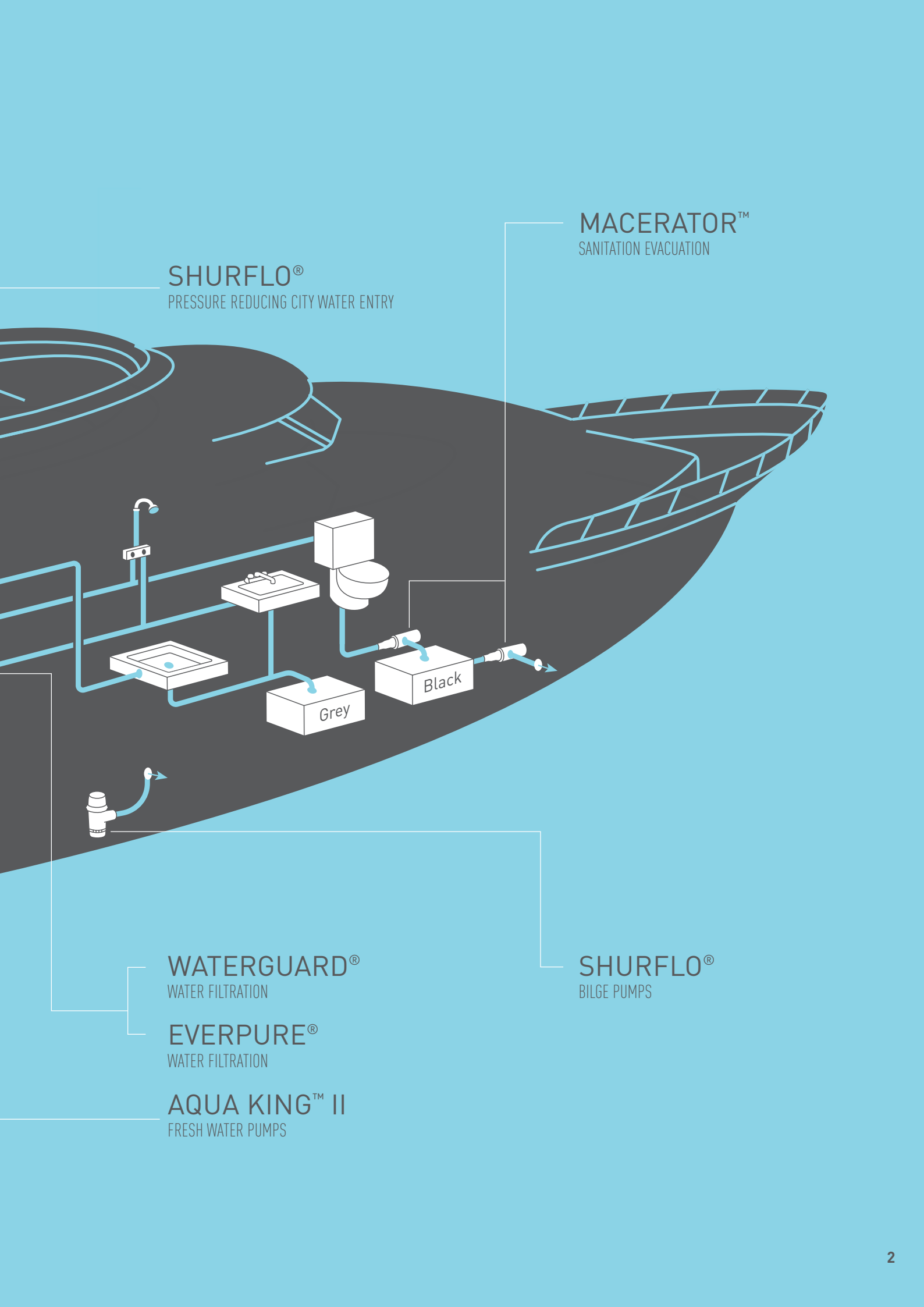

**SHURFLO®**  
PRESSURE REDUCING CITY WATER ENTRY

**MACERATOR™**  
SANITATION EVACUATION

Grey

Black

**WATERGUARD®**  
WATER FILTRATION

**EVERPURE®**  
WATER FILTRATION

**AQUA KING™ II**  
FRESH WATER PUMPS

**SHURFLO®**  
BILGE PUMPS

# FRESH WATER PUMPS

## AQUA KING™ II FRESH WATER PUMPS 2.0 GPM & 3.0 GPM



Name	OEM Model # (Aftermarket)	Description	Voltage	Dimensions	Flow Rate	Amps (Max.)	Shut-Off Pressure
Aqua King™ II Junior 2.0	4129-110-A02 (4129-110-B02)	Intermittent Duty Up to 2 Fixtures	12 VDC	8.2" x 4.9" x 4.1" [208 x 124 x 104mm]	2.0 GPM [7.6 LPM]	3	20 PSI [1.4 BAR]
Aqua King™ II Standard 3.0	4128-110-A04 (4128-110-E04)	Intermittent Duty Up to 2 Fixtures	12 VDC	8.2" x 4.9" x 4.1" [208 x 124 x 104mm]	2.0 GPM [7.6 LPM]	3.5	30 PSI [2.0 BAR]
Aqua King™ II Standard 3.0	4139-111-A54 (4139-111-B54)	Intermittent Duty Multi-Fixture Application	12 VDC	8.2" x 4.9" x 4.1" [208 x 124 x 104mm]	3.0 GPM [11.35 LPM]	4.5	30 PSI [2.0 BAR]
Aqua King™ II Standard 3.0	4139-111-A87 (4139-111-B87)	Intermittent Duty Multi-Fixture Application	12 VDC	8.2" x 4.9" x 4.1" [208 x 124 x 104mm]	3.0 GPM [11.35 LPM]	5.3	45 PSI [3.1 BAR]
Aqua King™ II Standard 3.0	4139-131-A54 (4139-131-B54)	Intermittent Duty Multi-Fixture Application	24 VDC	8.2" x 4.9" x 4.1" [208 x 124 x 104mm]	3.0 GPM [11.35 LPM]	2.5	30 PSI [2.0 BAR]
Aqua King™ II Standard 3.0	4139-131-A87 (4139-131-B87)	Intermittent Duty Multi-Fixture Application	24 VDC	8.2" x 4.9" x 4.1" [208 x 124 x 104mm]	3.0 GPM [11.35 LPM]	3	45 PSI [3.1 BAR]

The Shurflo Aqua King™ II Junior and Standard Fresh Water Pumps' design was created with unique over-molded single-piece diaphragm and internal by-pass (3.0 version only), assuring long life and top performance in all plumbing systems. These fresh water automatic demand pumps are quiet and can run dry without damage. Sealed switch. Ignition protected. Thermally protected. 2 each 1/2" (13mm) hose barb fittings are included (aftermarket models only).

**3 Year Warranty**

## AQUA KING™ II FRESH WATER PUMPS 4.0



Name	OEM Model # (Aftermarket)	Description	Voltage	Dimensions	Flow Rate	Amps (Max.)	Shut-Off Pressure
Aqua King™ II Premium 4.0	4149-153-A86 (4149-153-B86)	Intermittent Duty Multi-Fixture Application	12 VDC	10" x 5" x 4.75" [254 x 127 x 120mm]	4.0 GPM [15.1 LPM]	10	40 PSI [2.8 BAR]
Aqua King™ II Premium 4.0	4148-153-A75 (4148-153-E75)	Intermittent Duty Multi-Fixture Application	12 VDC	10" x 5" x 4.75" [254 x 127 x 120mm]	4.0 GPM [15.1 LPM]	10	55 PSI [3.8 BAR]
Aqua King™ II Premium 4.0	4148-163-A75 (4148-163-E75)	Intermittent Duty Multi-Fixture Application	24 VDC	10" x 5" x 4.75" [254 x 127 x 120mm]	4.0 GPM [15.1 LPM]	5	55 PSI [3.8 BAR]

The Shurflo Aqua King™ II Premium Fresh Water Pumps are designed for boats with multi-fixtures providing "just like home" shower pressure. A built in mechanical bypass function enables these pumps to operate at lower flow conditions with minimal cycling. Featuring heavy duty, seamless shell electro coated motors built to withstand the tough marine environment with o-ring sealed end bells and completely sealed wire entries. Sealed switch. Ignition protected. Thermally protected. Inlet strainer and 2 each 1/2" (13mm) hose barb fittings are included (aftermarket models only).

**3 Year Warranty**

## AQUA KING™ II FRESH WATER PUMPS 5.0



Name	OEM Model # (Aftermarket)	Description	Voltage	Dimensions	Flow Rate	Amps (Max.)	Shut-Off Pressure
Aqua King™ II Supreme 5.0	4158-153-A75 (4158-153-E75)	Intermittent Duty Multi-Fixture Application	12 VDC	10" x 5" x 4.75" [254 x 127 x 120mm]	5.0 GPM [18.9 LPM]	13	55 PSI [3.8 BAR]
Aqua King™ II Supreme 5.0	4158-163-A75 (4158-163-E75)	Intermittent Duty Multi-Fixture Application	24 VDC	10" x 5" x 4.75" [254 x 127 x 120mm]	5.0 GPM [18.9 LPM]	7	55 PSI [3.8 BAR]

The Shurflo Aqua King™ II Supreme Fresh Water Pumps are designed for boats with multi-fixtures providing "just like home" shower pressure. A built in mechanical bypass function enables these pumps to operate at lower flow conditions with minimal cycling. Featuring heavy duty, seamless shell electro coated motors built to withstand the tough marine environment with o-ring sealed end bells and completely sealed wire entries. Sealed switch. Ignition protected. Thermally protected. Inlet strainer and 2 each 1/2" (13mm) hose barb fittings are included (aftermarket models only).

**3 Year Warranty**

## HIGH FLOW SYSTEMS

Name	OEM Model # (Aftermarket)	Description	Voltage	Flow Rate	Amps (Max.)	Shut-Off Pressure
High Flow System	4558-153-E75 (4558-153-E75)	12 VDC High Flow System AQUA KING™ II Supreme 5.0 GPM [18.9 LPM] and PRO BLASTER™ II Ultimate 5.0 GPM [18.9 LPM], Manifold assembly and Mounting Board	12 VDC	10.0 GPM [37.8 LPM]	13/11	55 PSI [3.8 BAR]
High Flow System	4558-163-E75 (4558-163-E75)	24 VDC High Flow System AQUA KING™ II Supreme 5.0 GPM [18.9 LPM] and PRO BLASTER™ II Ultimate 5.0 GPM [18.9 LPM], Manifold assembly and Mounting Board	24 VDC	10.0 GPM [37.8 LPM]	7/6	55 PSI [3.8 BAR]



CE

The most advanced systems available. These fully-automatic, quiet units deliver water smoothly and consistently  
**3 Year Warranty**

## SLV PUMP

Name	OEM Model # (Aftermarket)	Description	Voltage	Dimensions	Flow Rate	Amps (Max.)	Shut-Off Pressure
SLV	105-003 (105-013)	Automatic Demand Pump	12 VDC	6.8" x 3.9" x 2.5" [170 x 100 x 60mm]	1.0 GPM [3.8 LPM]	2.5	30 PSI [2.0 BAR]



CE

This compact automatic demand pump offers durability and dependability making it ideal for low volume, intermittent duty applications. The SLV Pump self-primers up to 2.5 (.762m) vertical feet while delivering 1.0 GPM [3.8 LPM].

**1 Year Warranty**

# WASHDOWN PUMPS

## BLASTER™ II WASHDOWN PUMPS



CE

Name	OEM Model # (Aftermarket)	Voltage	Dimension	Flow Rate	Amps (Max.)	Shut-Off Pressure
Blaster™ II	4238-121-A07 (4238-121-E07)	12 VDC	9" x 4.9" x 4.1" [229 x 124 x 104mm]	3.5 GPM [13.2 LPM]	7.5	45 PSI [3.1 BAR]
Blaster™ II	4238-141-A07 (4238-141-E07)	24 VDC	9" x 4.9" x 4.1" [229 x 124 x 104mm]	3.5 GPM [13.2 LPM]	3.5	45 PSI [3.1 BAR]

The Shurflo Blaster™ II Washdown Pump design was created with a unique over-molded single-piece diaphragm, assuring long life and top performance in all marine washdown applications. The Blaster™ II washdown automatic demand pumps are thermally protected and can run dry without damage. Sealed switch. Ignition protected. 2 each 3/4" (19mm) hose barb fittings, 1 each 3/4" (19mm) GHT (M) fitting and nozzle included (aftermarket models only).

**2 Year Warranty**

## PRO BLASTER™ II WASHDOWN PUMPS



A



B

CE

Name	OEM Model # (Aftermarket)	Voltage	Dimension	Flow Rate	Amps (Max.)	Shut-Off Pressure
Pro Blaster™ II Deluxe 4.0 (A)	4248-153-A09 (4248-153-E09)	12 VDC	10" x 5" x 4.75" [254 x 127 x 120mm]	4.0 GPM [15.1 LPM]	10	60 PSI [4.1 BAR]
Pro Blaster™ II Deluxe 4.0 (A)	4248-163-A09 (4248-163-E09)	24 VDC	10" x 5" x 4.75" [254 x 127 x 120mm]	4.0 GPM [15.1 LPM]	5	60 PSI [4.1 BAR]
Pro Blaster™ II Ultimate 5.0 (B)	4258-153-A09 (4258-153-E09)	12 VDC	10" x 5" x 4.75" [254 x 127 x 120mm]	5.0 GPM [18.9 LPM]	14	60 PSI [4.1 BAR]
Pro Blaster™ II Ultimate 5.0 (B)	4258-163-A09 (4258-163-E09)	24 VDC	10" x 5" x 4.75" [254 x 127 x 120mm]	5.0 GPM [18.9 LPM]	7	60 PSI [4.1 BAR]

The Shurflo Pro Blaster™ II Washdown Pumps deliver superior performance that customers have come to expect and rely upon. Whether it is blasting away the grime on your deck, fish box scaling or anchor chain cleaning, The Shurflo Pro Blaster™ II Washdown Pumps deliver high performance that provide a powerful consistent spray pattern. Built to withstand the tough marine environment with electro-coated motor, o-ring seals and fully sealed wire entries. Sealed switch. Ignition protected. Thermally protected. Inlet strainer, 2 each 3/4" (19mm) hose barb fittings, 1 each 3/4" (19mm) GHT (M) fitting and nozzle included (aftermarket models only).

**2 Year Warranty**

## RAW WATER STRAINERS



A



B

CE

Name	OEM Model # (Aftermarket)	Description
1/2" (13mm) Strainer (A) with fittings	253-120-00 (253-120-01)	50 Mesh Screen
1/2" (13mm) Strainer with bracket & fittings	253-121-01 (253-121-01)	50 Mesh Screen
3/4" (19mm) Strainer	253-220-00 (253-220-01)	50 Mesh Screen
3/4" (19mm) Strainer with bracket & fittings	253-221-01 (253-221-01)	50 Mesh Screen
1" (25mm) Strainer (B)	253-320-00 (253-320-01)	50 Mesh Screen
1" (25mm) Strainer with bracket & fittings	253-321-01 (253-321-01)	50 Mesh Screen
1-1/4" (38mm) Strainer	253-400-00 (253-400-01)	20 Mesh Screen
1-1/4" (38mm) Strainer with bracket & fittings	253-401-01 (253-401-01)	20 Mesh Screen

The Shurflo family of Raw Water Strainers are built to keep your bait tank, livewell and washdown pumps protected from harmful debris. The Raw Water Strainer features a high capacity, rugged nylon housing with clear twist off polyamide bowl and removable stainless steel screen, which allows for easy inspection and cleaning. An integral o-ring creates a tight seal, eliminating possible leaks.

**1 Year Warranty**





### BLASTER™ II WASHDOWN KIT

Name	OEM Model # (Aftermarket)	Description	Dimension	Voltage	Flow Rate	Amps (Max.)	Shut-Off Pressure
Blaster™ II Washdown Kit 3.5	4338-121-A07 (4338-121-E07)	BLASTER™ II 3.5 Pump, Fittings, Nozzle, Strainer, 25' (7.6m) 3/8" (10mm) coiled hose	9" x 4.9" x 4.1" [229 x 124 x 104mm]	12 VDC	3.5 GPM [13.2 LPM]	7.5	45 PSI [3.1 BAR]

The Shurflo Blaster™ II Washdown Kit includes everything you need for washdown applications in fish box, scaling, anchor chain cleaning and blasting down the grimeiest decks all in one convenient package. The kit includes the Blaster™ II 3.5 GPM (13.2 LPM) pump, nozzle, strainer, fittings and a UV protected 25' (7.6m) coiled hose.

**2 Year Warranty**



### PRO WASHDOWN KIT II

Name	OEM Model # (Aftermarket)	Description	Dimension	Voltage	Flow Rate	Amps (Max.)	Shut-Off Pressure
Pro Washdown Kit II Deluxe 4.0 (A)	4348-153-A09 (4348-153-E09)	Pro Blaster™ II Deluxe 4.0 Pump, Fittings, Nozzle, Raw Water Strainer, 25' (7.6m) 3/8" (10mm) coiled hose	10" x 5" x 4.75" [254 x 127 x 120mm]	12 VDC	4.0 GPM [15.1 LPM]	10	60 PSI [4.1 BAR]
Pro Washdown Kit II Ultimate 5.0	4358-153-A09 (4358-153-E09)	Pro Blaster™ II Ultimate, 5.0 Pump, Fittings, Nozzle, Raw Water Strainer, 25' (7.6m) 1/2" (13mm) coiled hose	10" x 5" x 4.75" [254 x 127 x 120mm]	12 VDC	5.0 GPM [18.9 LPM]	14	60 PSI [4.1 BAR]

The Shurflo Pro Washdown Kit II is available in both Deluxe 4.0 and Ultimate 5.0 series. These kits include everything you need for those tough washdown applications in fish box, scaling, anchor chain cleaning and blasting down the grimeiest decks all in one kit! The kits include a washdown pump (Deluxe 4.0 or Ultimate 5.0), Fittings, Nozzle, Raw Water Strainer and a 25' (7.6m) coiled hose.

**2 Year Warranty**

# LIVEWELL PUMPS

## PRO BAITMASTER™ II LIVEWELL PUMPS



Name	OEM Model # (Aftermarket)	Description	Voltage	Dimension	Flow Rate	Amps (Max.)	Shut-Off Pressure
Pro Baitmaster™ II	4648-153-A07 (4648-153-E07)	Continuous Duty, Splash Proof, Sealed Motor, Ignition Protected	12 VDC	10" x 5" x 4.75" [254 x 127 x 120mm]	4.0 GPM [15.1 LPM]	8	45 PSI [3.1 Bar]
Pro Baitmaster™ II	4648-163-A07 (4648-163-E07)	Continuous Duty, Splash Proof, Sealed Motor, Ignition Protected	24 VDC	10" x 5" x 4.75" [254 x 127 x 120mm]	4.0 GPM [15.1 LPM]	4	45 PSI [3.1 Bar]

The Shurflo Pro Baitmaster™ II Heavy Duty Livewell/Washdown Pumps are excellent for livewell or washdown applications in harsh marine environments. The seamless motor shell and sealed switch protects the pump from splashed liquids. Self-priming and can run dry without damage. For tank size 35 gallons (132.5L) and under. Thermally protected. Ignition protected.

**2 Year Warranty**

## BAIT SENTRY™ LIVEWELL PUMPS



A



Name	OEM Model # (Aftermarket)	Description	Tank Size (Gallons)	Dimension	Port Size Inlet/Outlet	Flow Rate	Amps (Max.)
Bait Sentry™ 500 Magnetic Drive	1700-000-030 (1700-001-030)	12 VDC, Continuous Duty, Ignition Protected, ISO 8846	30	4.93" x 7.85" [125 x 200mm]	3/4" (19mm) Inlet NPT 3/4" (19mm) Outlet BARB	500 GPH [1893 LPH]	1.7
Bait Sentry™ 800 Magnetic Drive	1700-010-030 (1700-011-030)		40	4.93" x 7.85" [125 x 200mm]	3/4" (19mm) Inlet NPT 3/4" (19mm) Outlet BARB	800 GPH [3028 LPH]	4
Bait Sentry™ 1100 Magnetic Drive (A)	1700-020-030 (1700-021-030)		60	4.93" x 7.85" [125 x 200mm]	3/4" (19mm) Inlet NPT 1-1/8" (29mm) Outlet BARB	1100 GPH [4164 LPH]	4.2

The Bait Sentry™ Livewell Pumps are designed for easy installation and trouble-free operation. Magnetic Drive technology eliminates unnecessary failures. Patented anti-airlock feature allows the pump to clear trapped air in rough water or when boat is anchored. Includes dual port for easy washdown pump connection.

**3 Year Warranty**

# BILGE PUMPS

## 380 - 1000 GPH BILGE PUMPS

Name	OEM Model # [Aftermarket]	Description	Voltage	Dimension	Round Footprint	Port Size Outlet	Flow Rate	Amps (Max.)
Bilge 380	355-020-00 [355-020-10]	Continuous Duty, Submersible with 3' Tinned Wire Assembly, Anti-Airlock, ABS Housing w/ Nylon Impeller, Ignition Protected, ISO 8849	12 VDC	4.2" x 3.75" [114 x 95mm]	2-3/8" [86mm]	3/4" [19mm]	380 GPH [1438 LPH]	1.7
Bilge 500	355-010-00 [355-010-10]		12 VDC	4.2" x 3.75" [114 x 95mm]	2-3/8" [86mm]	3/4" [19mm]	500 GPH [1893 LPH]	1.8
Bilge 700	355-110-00 [355-110-10]		12 VDC	4.2" x 3.75" [114 x 95mm]	2-3/8" [86mm]	3/4" [19mm]	700 GPH [2650 LPH]	3.2
Bilge 1000	355-100-00 [355-100-10]		12 VDC	4.2" x 3.75" [114 x 95mm]	2-3/8" [86mm]	1-1/8" [29mm]	1000 GPH [3785 LPH]	3.2



CE

Quality bilge pumps you can trust. The Shurflo bilge pumps are built for the harsh marine environment to withstand the toughest conditions. Standard with 3' (.91m) tinned wire assembly for below waterline installations.

**3 Year Warranty**

## 1500 - 2000 GPH BILGE PUMPS

Name	OEM Model # [Aftermarket]	Description	Voltage	Dimension	Port Size Outlet	Flow Rate	Amps (Max.)
Bilge 1500	358-000-00 [358-000-10]	Continuous Duty, Submersible with 6' [1.8 m] Tinned Wire Assembly, Anti-Air lock, Swivel Baseplate, Ignition Protected, ISO 8849	12 VDC	7.2" x 6.3" [184 x 160mm]	1-1/8" [29mm] Outlet Barb	1500 GPH [5677 LPH]	8
Bilge 2000	358-010-00 [358-010-10]		12 VDC	7.2" x 6.3" [184 x 160mm]	1-1/8" [29mm] Outlet Barb	2000 GPH [7569 LPH]	10
Bilge 1500	358-100-00 [358-100-10]		24 VDC	7.2" x 6.3" [184 x 160mm]	1-1/8" [29mm] Outlet Barb	1500 GPH [5677 LPH]	4
Bilge 2000	358-110-00 [358-110-10]		24 VDC	7.2" x 6.3" [184 x 160mm]	1-1/8" [29mm] Outlet Barb	2000 GPH [7569 LPH]	5



CE

Heavy duty and built to last. The Shurflo 1500 and 2000 GPH (5677 and 7569 LPH) nylon bilge pumps offer a unique motor cooling system (patent pending) to ensure efficient performance and long life. Installation is a snap with our patented swivel base and 6' (1.8m) tinned wire assembly.

**3 Year Warranty**

## BILGE SWITCH

Name	OEM Model # [Aftermarket]	Description	Voltage	Dimension	Amps (Max.)
Standard Automatic Float Switch (A)	359-101-30 [359-111-30]	Non-Mercury, Remote or Direct Mounting 3' (.91m) Tinned Wire Assembly, Ignition Protected, ISO 8849	12/24 VDC	4.4" x 3.6" x 1.3" [112 x 92 x 32mm]	12
Caged Automatic Float Switch (B)	359-101-40 [359-111-40]	Non-Mercury, Remote or Direct Mounting 3' (.91m) Tinned Wire Assembly, Ignition Protected, ISO 8849	12/24 VDC	5.1" x 4.0" x 2.8" [130 x 102 x 71mm]	12



B

CE

The Shurflo series float switches provide the ultimate in reliability for your boat. Complete line includes a standard automatic float switch and a caged automatic float switch.

**3 Year Warranty**

# GENERAL PURPOSE PUMPS

## GENERAL PURPOSE PUMPS



Name	OEM Model # (Aftermarket)	Description	Dimensions	Flow Rate	Amps (Max.)	Port Size
General Purpose Pump Standard (A)	8050-305-526 [8050-305-526]	12 VDC - Ignition Protected. BUNA Valves, CE, 7' [2.1m] Prime, Hose kit Included, Uses: Winterizing, Oil Change and Liquid Transfers	6.5" x 4.5" x 4.3" [165 x 114 x 108mm]	1.5 GPM [5.6 LPM]	4	3/8" (10mm) F NPT
General Purpose Pump Premium (B)	8050-305-626 [8050-305-626]	12 VDC - Ignition Protected. BUNA Valves, CE, 7' [2.1m] Prime, 8' Cable with Battery Clips, Hose kit Included, Uses: Winterizing, Oil Change and Liquid Transfers	7.8" x 4.5" x 4.3" [198 x 114 x 108mm]	1.5 GPM [5.6 LPM]	4	3/8" (10mm) F NPT
Oil Change/Winterizing System (C)	8050-305-426 [8050-305-426]	12 VDC - 8' [2.4 m] Cable w/ Battery Clips, CE, Hose kit and 3.5 Gal [13L] Storage Container, Uses: Oil changing, winterizing and liquid transfer	16" H x 12.5" D [406 x 318mm]	1.5 GPM [5.6 LPM]	4	3/8" (10mm) F NPT
Drill Pump (D)	3010-000 [3010-000]	1/4" [6mm] Drill Shaft - Flexible BUNA Impeller, 8' [2.4m] Prime, Uses: Oil Change and Liquid Transfers	—	200 GPH [757 LPH]	—	3/4" (19mm) GSH M
Nautilus™ (E)	100-049-21	12 VDC - Single Fixture Water Delivery, Thermal Overload, Must have In-Line Switch & 3 Amp Fuse, Uses: Single Fixture Applications	4.8" x 2.6" x 1.9" [122 x 66 x 49mm]	1.0 GPH [4.0 LPH]	2.5	3/8" Barb (10mm)

Easy to install and are extremely versatile—perfect for a variety of uses including winterizing, oil changing and liquid transfer. Thermally protected.

**1 Year Warranty**

## SPECIALTY PUMPS

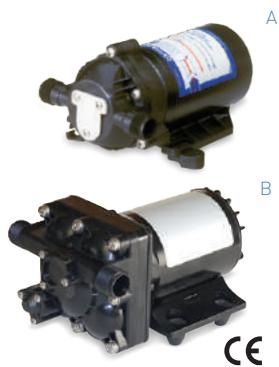

Name	OEM Model # (Aftermarket)	Description	Dimensions	Flow Rate	Amps (Max.)	Maximum Pressure
Refrigeration Circulation Pump (A)	8050-261-105 [8050-261-105]	12 VDC-CE Version, No switch, Continuous Duty Motor, Cold Plate Refrigeration Pump	7.3" x 4.3" x 4.4" [185 x 109 x 112mm]	0.5 GPM [1.9 LPM]	1.5	30 PSI [2.1 BAR]
Refrigeration Circulation Pump (B)	4728-110-E10 [4728-110-E10]	12 VDC-CE Version, No switch, Continuous Duty Motor, Cold plate Refrigeration Pump	7.2" x 4.9" x 4.5" [183 x 125 x 114mm]	2 GPM [7.5 LPM]	3.5	45 PSI [3.1 BAR]

Specifically designed for refrigeration cold plate circulation, each pump features a positive displacement diaphragm and EPDM valves for proven priming ability and longer life.

**1 Year Warranty**

## CLOSED COUPLE CENTRIFUGAL PUMPS



Name	Model #	Voltage	Dimensions	Flow Rate	Amps (Max.)	Maximum Pressure
Centrifugal Pump	COMSV012D	12 VDC	7.2" x 4" x 4" [182 x 102 x 102mm]	21 GPM [79.4 LPM]	10.4	10 PSI [0.7 BAR]
Centrifugal Pump	COMSV024D	12 VDC	7.2" x 4" x 4" [182 x 102 x 102mm]	21 GPM [79.4 LPM]	7.8	10 PSI [0.7 BAR]

Shurflo close-coupled, 316 stainless steel, semi-open impeller centrifugal models pump continuously, producing high flow rates under low-head conditions. Designed for continuous low pressure circulation and transfer of nonflammable liquids, utility, boiler feed, general transfer, marine applications, water circulation, engine cooling where no suction lift or no self-priming is required.

**1 Year Warranty**

# BLOWERS IN-LINE

## YELLOWTAIL™ IN-LINE BLOWERS

Name	OEM Model # (Aftermarket)	Description	Dimension	CFM	Amps (Max.)
3" YellowTail™ Blower (A)	277-3100 [277-3110]	12 VDC, CE, Continuous Duty, ISO 9097 Marine, Ignition Protected, USCG 183.410 Compliant, NMMA Type Accepted, ABYC	5.1" x 5.5" x 3.8" [130 x 140 x 96mm]	120	3.7
4" YellowTail™ Blower (B)	277-4100 [277-4110]	12 VDC, CE, Continuous Duty, ISO 9097 Marine, Ignition Protected, USCG 183.410 Compliant, NMMA Type Accepted, ABYC	5.1" x 6.4" x 4.8" [130 x 162 x 122mm]	220	5.2



Shurflo has developed a unique nylon fan that includes 6 blades to ensure high performance and efficient ventilation. Installation of the Yellowtail™ Blower is made easy with extended barbs and slotted mounting bracket. **3 Year Warranty**

# MACERATOR PUMPS

## MACERATOR PUMPS

Name	OEM Model # (Aftermarket)	Voltage	Dimension	Flow Rate	Amps (Max.)	Port Size
Macerator 12 VDC (A)	3200-000 [3200-001]	12 VDC	10.6" x 4.9" x 3.8" [269 x 125 x 97mm]	13 GPM [49 LPM]	17	Inlet 1-1/2" (38mm) Barb/1-1/2" (38mm) NPT Outlet 1" (25mm) Barb
Macerator 12 VDC 180 Degree Port	3200-100 [3200-101]	12 VDC	10.6" x 4.9" x 3.8" [269 x 125 x 97mm]	13 GPM [49 LPM]	17	Inlet 1-1/2" (38mm) Barb/1-1/2" (38mm) NPT Outlet 1" (25mm) Barb
Macerator 24 VDC	3200-010 [3200-011]	24 VDC	10.6" x 4.9" x 3.8" [269 x 125 x 97mm]	13 GPM [49 LPM]	9	Inlet 1-1/2" (38mm) Barb/1-1/2" (38mm) NPT Outlet 1" (25mm) Barb
Macerator 24 VDC 180 Degree Port	3200-110	24 VDC	10.6" x 4.9" x 3.8" [269 x 125 x 97mm]	13 GPM [49 LPM]	9	Inlet 1-1/2" (38mm) Barb/1-1/2" (38mm) NPT Outlet 1" (25mm) Barb



Designed specifically for sanitation waste and fish box evacuations, the Shurflo Macerator pump features a premium impeller design with run-dry capability and includes our seamless shell motor with o-ring sealed end bells and a sealed manual turn key. The unique dual blade and housing construction ensure problem free pumping, providing superior performance in harsh marine environments. Thermally protected and ignition protected.

**1 Year Warranty**

# ACCESSORIES



## PRE-PRESSURIZED ACCUMULATOR TANKS

Name	OEM Model # [Aftermarket]	Dimensions	Total Volume	Maximum PSI	Precharged
24 oz. Nylon Tank 1/2" NPT-M (A)	182-100 [182-200]	9.1" x 4.8" x 3.8" [232 x 121 x 97mm]	24 oz. [710 ml]	125 PSI [8.8 BAR]	30 PSI [2.0 BAR]
24 oz. Nylon Tank 1/2" NPT-F	182-102 [182-202]	9.1" x 4.8" x 3.8" [232 x 121 x 97mm]	24 oz. [710 ml]	125 PSI [8.8 BAR]	20 PSI [1.4 BAR]
2 Gallon Stainless Steel Tank (B)	3400-002 [3400-002]	12" H, 9" D [23cm H, 10cm D]	2 Gallons [8 L]	100 PSI [7 BAR]	20 PSI [1.4 BAR]

Reduce cycling pulsation and pressure spikes, increase the life of your pump—and even save battery power. Easily handles pressure requirements from 20 PSI to 125 PSI (1.4 BAR to 8.8 BAR).

**1 Year Warranty**

## WATER SYSTEM ACCESSORIES



Name	OEM Model # [Aftermarket]	Description	Designation
Twist-On Water Strainer	255-223 [255-323]	Easy Assembly, keeps debris out of pump, Transparent, easy to see when strainer needs cleaning, 50 Mesh Stainless Steel Screen	1/2" [13mm] Barb Inlet
Twist-On Water Strainer (A)	255-213 [255-313]	Easy Assembly, keeps debris out of pump, Transparent, easy to see when strainer needs cleaning, 50 Mesh Stainless Steel Screen	1/2" [13mm] Pipe Inlet
Swivel Nut Water Strainer	255-215 [255-315]	Easy Assembly, keeps debris out of pump, Transparent, easy to see when strainer needs cleaning, 50 Mesh Stainless Steel Screen	1/2" [13mm] Pipe Inlet
Swivel Nut Water Strainer (B)	255-225 [255-325]	Easy Assembly, keeps debris out of pump, Transparent, easy to see when strainer needs cleaning, 50 Mesh Stainless Steel Screen	1/2" [13mm] Barb Inlet
Barb Inlet Strainer	255-222 [255-322]	Easy Assembly, keeps debris out of pump, Transparent, easy to see when strainer needs cleaning, 50 Mesh Stainless Steel Screen	1/2" [13mm] Pipe Inlet
In-Line Check Valve (C)	340-000 [340-001]	Allows flow in one direction only to safeguard against backsurge up to 100 PSI [6.8 BAR]	1/2" [13mm] Barb
High Pressure Blaster™ Nozzle (D)	15-010 [94-010-00]	High Impact Plastic for long life, use with Shurflo Pumps or garden hose, adjusts to fine mist or full stream, lock clip for continuous spray	3/4" [19mm] Garden Hose Thread
Self-Coiling Hose (E)	7-071-25 [7-071-25]	25' [7.6m], 3/8" [9.5mm] Diameter, White Coiled Hose	3/4" [19mm] Garden Hose Thread
Self-Coiling Hose (F)	7-137-25 [7-137-25]	25' [7.6m], 1/2" [13mm] Diameter, Blue Coiled Hose	3/4" [19mm] Garden Hose Thread

Designed for safety and convenience, Shurflo accessories are built to last. Big protection from small, yet essential products

**1 Year Warranty**

## PRESSURE REDUCING CITY WATER ENTRIES



Name	OEM Model # [Aftermarket]	OEM Model # [Aftermarket]	Color
	50 PSI Model		
Wall Mount (A)	183-020-04 [183-029-04]	183-020-14 [183-029-14]	Chrome
Wall Mount (B)	183-020-06 [183-029-06]	183-020-16 [183-029-16]	Black
Wall Mount (C)	183-020-08 [183-029-08]	183-020-18 [183-029-18]	Gel White
In-Line (D)	[183-039-08]	N/A	Gel White

The exclusive Shurflo diaphragm design prevents high-pressure damage often caused by city water. These high performance water entries limit water pressure and include a check valve. 3/4" (19mm) GHT- Female Swivel Inlet. 1/2" (13mm) NPSM - Male Outlet. 1/2" (13mm) swivel elbow fitting included.

**1 Year Warranty**

# FILTRATION

## PENTAIR IN-LINE WATER FILTERS WATERGUARD™

Model #	Cartridge Media	Description	Taste & Chlorine	Heavy Metals	THM's VOC's	Pesticides	Micron Rating	Fittings/Port Size and Accessories
RV-210GH-A City Water Entry In-Line Filter (A)	Activated Carbon	Long life triple-stage Carbon in-line city water entry filter with garden hose ends	•		•	•	5	3/4" (19mm) Garden Hose Ports
RV-210GH-KDF-A City Water Entry In-Line Filter	KDF /Carbon	Long life, high quality quad-stage bacteriostatic KDF/carbon in-line city water entry filter with garden hose ends	•	•	•	•	5	3/4" (19mm) Garden Hose Ports
RV-210BRB-A 11" City Water Entry In-Line Filter)	Activated Carbon	Long life, triple-stage Carbon in-line city water entry filter with 1/4" (6mm) Barb fittings	•		•	•	5	1/2" (13mm) Barb Ports
94-009-50 10" In-Line Interior Filter (B)	KDF /Carbon	Long-life, high quality quad-stage bacteriostatic KDF/carbon in-line filter with fittings for every interior need	•	•	•	•	5	1/4" (6mm) NPT-F Both Ends, fittings included: 2 ea. 1/2" (13mm) MPT, 2 ea. Quick Connect & 2 ea. ColderFittings



A



B

CE

## EVERPURE® FILTERS

Model #	Cartridge Media	Description	Taste & Chlorine	Heavy Metals	Cyst†	THM's VOC's	Pesticides	Micron Rating ‡
EV959206 Everpure® Full-Timer (A)	Micro-Pure Pleated	Exclusive technology reduces 99.9% of all particles 0.5 micron in size	•		•	•		0.5
EV959207 Everpure® Part-Timer (B)	Carbon Block	Exclusive technology reduces 99.9% of all particles 0.5 micron in size, Twin-pack	•		•	•		0.5



A

B

CE

† Reduces cysts such as Cryptosporidium and Giardia by mechanical means.

‡ Reduces particles as small as 0.5 micron in size by mechanical means.

## COMPLETE AFTERMARKET FILTER SYSTEM COMPONENTS

Name	Model #	Includes	Description † ‡
Everpure® Complete Kit	EV925205	EV959206 Filter, Housing, By-Pass, Installation Kit	Exclusive Everpure® Filtration System, includes installation kit and super chlorination disinfection kit. Protects against bacteria, viruses and cysts down to 0.5 micron in size

† Reduces cysts such as Cryptosporidium and Giardia by mechanical means.

‡ Reduces particles as small as 0.5 micron in size by mechanical means.



CE

# PUMP FITTINGS

## STRAIGHT FITTINGS



Model # Straight Fittings	Style	Material	Description
244-2916	Wingnut Swivel	Nylon	1/2" (13mm) -15 NPT (F) x 3/8" (10mm) Barb
244-2926 (A)	Wingnut Swivel	Nylon	1/2" (13mm) -14 NPT (F) x 1/2" (13mm) Barb
244-2936	Wingnut Swivel	Nylon	1/2" (13mm) -14 NPT (F) x 5/8" (16mm) Barb
244-2946	Wingnut Swivel	Nylon	1/2" (13mm) -14 NPT (F) x 3/4" (19mm) Barb
244-5146	Adapter	Nylon	1/2" (13mm) -14 NPT (F) x 3/4" (19mm) Barb

## ELBOW FITTINGS

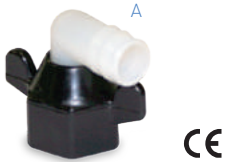

Model # Elbow Fittings	Style	Material	Description
244-3366	Wingnut Swivel	Nylon	1/2" (13mm)-14 NPT (F) x 1/2"(13mm) -14 NPT (M)
244-3916	Wingnut Swivel	Nylon	1/2" (13mm)-14 NPT (F) x 3/8" (10mm) Barb
244-3926 (A)	Wingnut Swivel	Nylon	1/2" (13mm)-14 NPT (F) x 1/2" (19mm) Barb
244-3936	Wingnut Swivel	Nylon	1/2" (13mm)-14 NPT (F) x 5/8" (16mm) Barb
244-3946	Wingnut Swivel	Nylon	1/2" (13mm)-14 NPT (F) x 3/4" (19mm) Barb

## GARDEN HOSE WINGNUT FITTING



Model # Wing Nut Fitting	Style	Material	Description
244-2356	Wingnut Swivel	Nylon	3/4" (19mm) GHT (M) x 1/2" (13mm)NPT (F)

## SWIVEL STRAIGHT FITTING ADAPTER



Model # Fitting Adapter	Style	Material	Description
244-2866	Wingnut Swivel (Pump/Accumulator Fitting)	Nylon	1/2" (13mm) NPT (F) x 1/2" (19mm)NPT (F)

## TEE FITTING



Model # Tee Fitting	Style	Material	Description
244-4522	Barb Tee	Polypropolene	1/2" (13mm) Barb x 1/2" (13mm) Barb x 1/2" (19mm) Barb



# PUMP REPAIR AND REBUILD KITS

Shurflo pumps have set the standard for marine performance and reliability. To keep that performance and reliability at its peak, Shurflo offers a wide range of kits for bench and field repair of its products. For detailed listings of individual part numbers, refer to Shurflo pricing guides and repair manuals. This overview indicates the type of kits available.

## 2901 / 3901 SERIES

Name	OEM Model # [Aftermarket]	Switch	Upper Housing	Valve Assembly	Drive Assembly
		1	2	3	4
Aqua King™ Standard 12 V 30 PSI (2.1 bar)	3901-0203 [3901-0213]	94-706-04	94-706-01	94-706-02	94-706-06
Aqua King™ Standard 24 V 30 PSI (2.1 bar)	3901-1203 [3901-1213]	94-706-04	94-706-01	94-706-02	94-706-06
Aqua King™ Standard 12 V 45 PSI (3.1 bar)	3901-0204 [3901-0214]	94-706-03	94-706-01	94-706-02	94-706-06
Aqua King™ Standard 24 V 45 PSI (3.1 bar)	3901-1204 [3901-1214]	94-706-03	94-706-01	94-706-02	94-706-06
Blaster™ 12 V 45 PSI (3.1 bar)	3901-2204 [3901-2214]	94-706-03	94-706-01	94-706-02	94-706-06
Blaster™ 24 V 45 PSI (3.1 bar)	3901-3204 [3901-3214]	94-706-03	94-706-01	94-706-02	94-706-06
Pro Blaster™ Junior 30 PSI (2.1 bar)	2901-6203 [2901-6213]	94-706-04	94-706-01	94-706-02	94-706-06
Aqua King™ Junior 12 V 30 PSI (2.1 bar)	2901-0203 [2901-0213]	94-706-04	94-706-01	94-706-02	94-706-06
Aqua King™ Junior 12 V 20 PSI (1.4 bar)	2901-0202 [2901-0212]	94-706-05	94-706-01	94-706-02	94-706-06

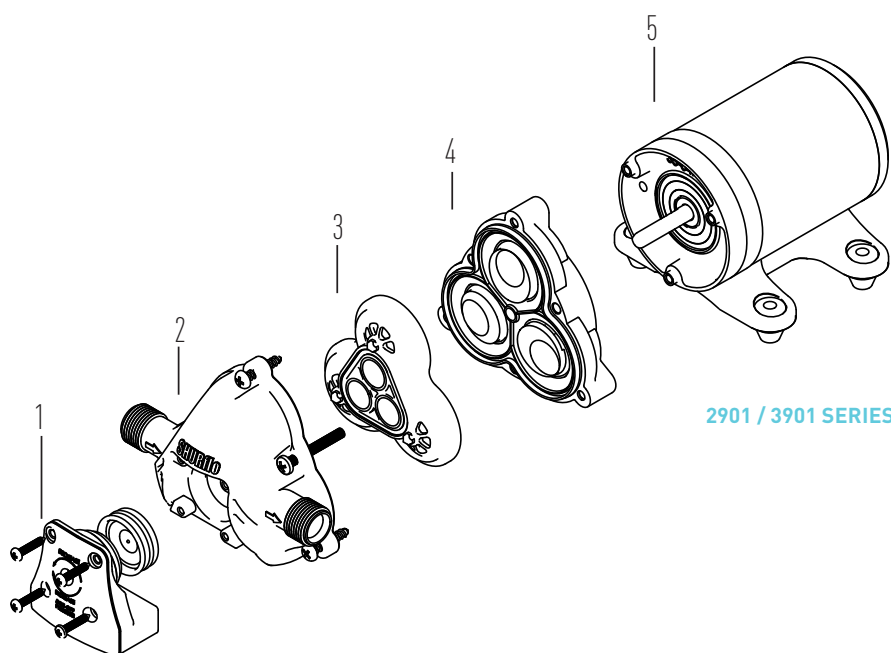

# PUMP REPAIR AND REBUILD KITS

## 4128 / 4129/ 4139 SERIES

Name	OEM Model # [Aftermarket]	Upper Assembly	Valve Assembly	Drive Assembly	Motor & Gasket	Pump Head	Check Valve [Not Shown]
		1	2	3	4	5	6
Aqua King™ II Junior 2.0	4128-110-A04 [4128-110-E04]	94-800-22	94-800-01	94-800-25	94-71-003-07	94-800-28	94-800-03
Aqua King™ II Junior 2.0	4129-110-A02 [4129-110-B02]	94-800-41	94-800-01	94-800-25	94-71-003-07	94-800-32	94-800-03
Aqua King™ II Standard 3.0	4139-111-A54 [4139-111-B54]	94-800-42	94-800-01	94-800-26	94-71-003-07	94-800-33	94-800-03
Aqua King™ II Standard 3.0	4139-111-A87 [4139-111-B87]	94-800-43	94-800-01	94-800-26	94-71-003-07	94-800-34	94-800-03
Aqua King™ II Standard 3.0	4139-131-A54 [4139-131-B54]	94-800-42	94-800-01	94-800-26	94-71-005-07	94-800-33	94-800-03
Aqua King™ II Standard 3.0	4139-131-A87 [4139-131-B87]	94-800-43	94-800-01	94-800-26	94-71-006-07	94-800-34	94-800-03

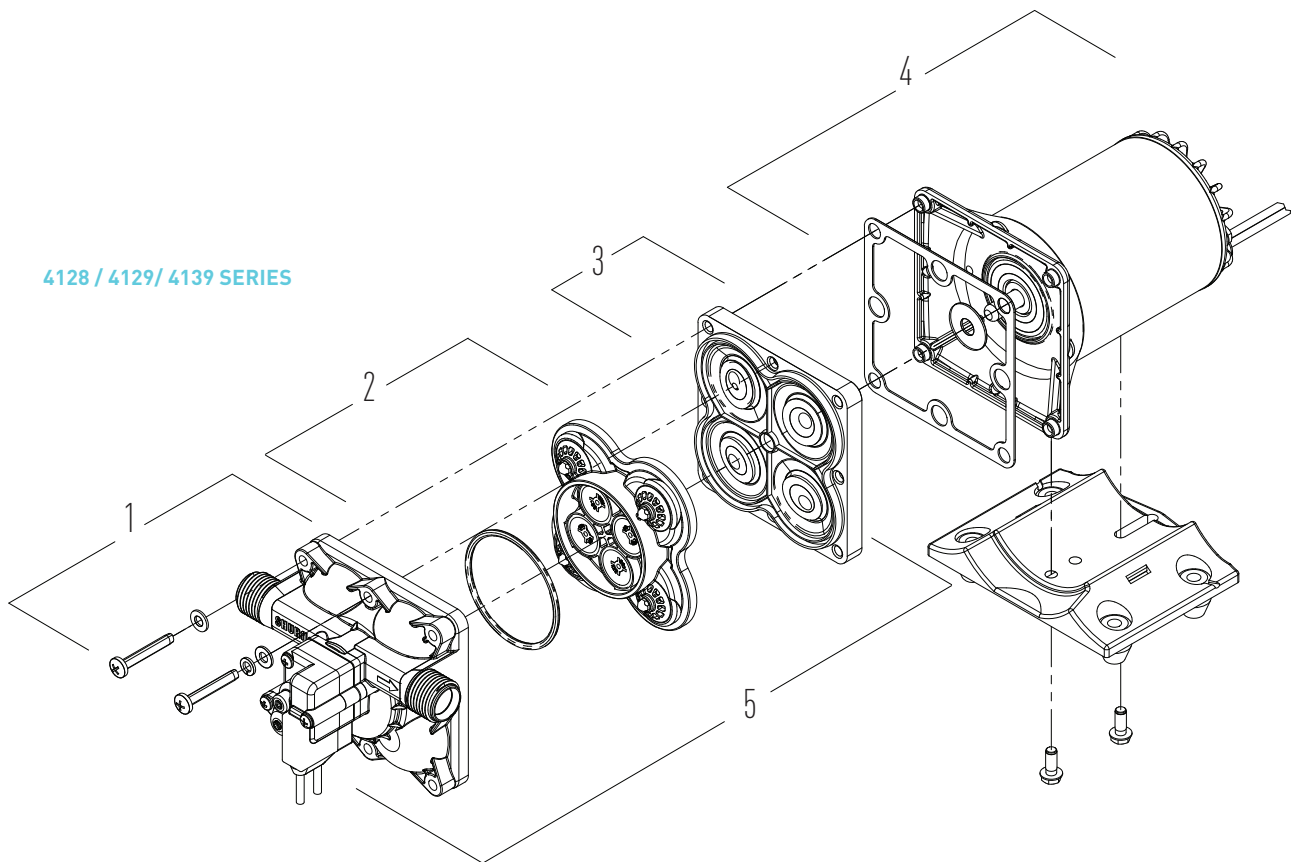

4128 / 4129/ 4139 SERIES

## 4148/4149/4158 SERIES

Name	OEM Model # (Aftermarket)	Upper Assembly	Valve Assembly	Drive Assembly	Motor & Gasket	Pump Head	Check Valve (Not Shown)
		1	2	3	4	5	6
Aqua King™ II Premium 4.0	4148-153-A75 [4148-153-E75]	94-801-10	94-800-01	94-801-02	94-71-001-07	94-801-11	94-800-03
Aqua King™ II Premium 4.0 24 VDC	4148-163-A75 [4148-163-E75]	94-801-10	94-800-01	94-801-02	94-71-001-03	94-801-11	94-800-03
Aqua King™ II Premium 4.0	4149-153-A86 [4149-153-B86]	94-801-16	94-800-01	94-801-02	94-71-001-07	94-801-17	94-800-03
Aqua King™ II Supreme 5.0	4158-153-A75 [4158-153-E75]	94-801-10	94-800-01	94-801-12	94-71-000-17	94-801-13	94-800-03
Aqua King™ II Supreme 5.0 24 VDC	4158-163-A75 [4158-163-E75]	94-801-10	94-800-01	94-801-12	94-71-001-04	94-801-13	94-800-03

## 4148 / 4149 / 4158 / 4558 SERIES

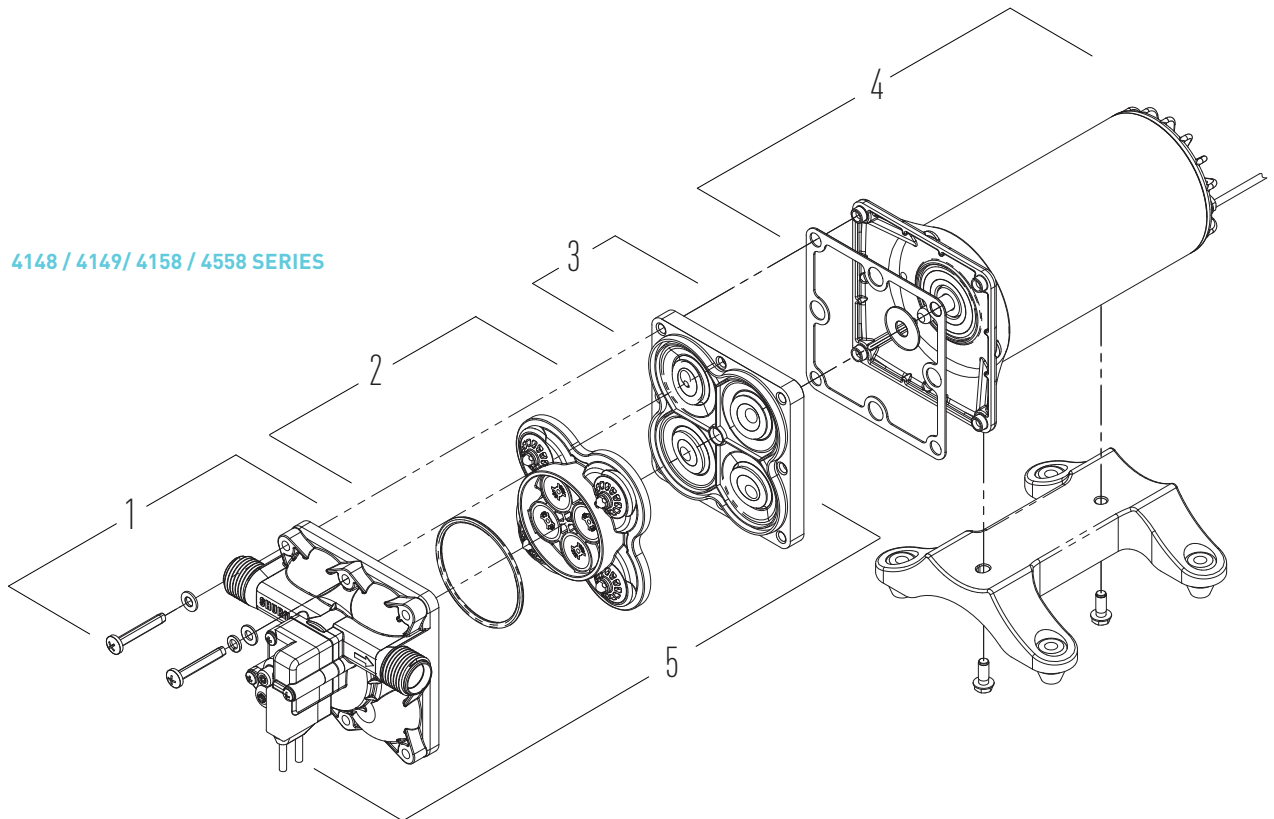

# PUMP REPAIR AND REBUILD KITS

## 4238 SERIES

Name	OEM Model # (Aftermarket)	Upper Assembly	Valve Assembly	Drive Assembly	Motor & Gasket	Pump Head	Check Valve (Not Shown)
		1	2	3	4	5	6
Blaster™ II	4238-121-A07 [4238-121-E07]	94-800-13	94-800-01	94-800-15	94-71-002-07	94-800-17	94-800-03
Blaster™ II 24 VDC	4238-141-A07 [4238-141-E07]	94-800-13	94-800-01	94-800-15	94-71-001-17	94-800-17	94-800-03

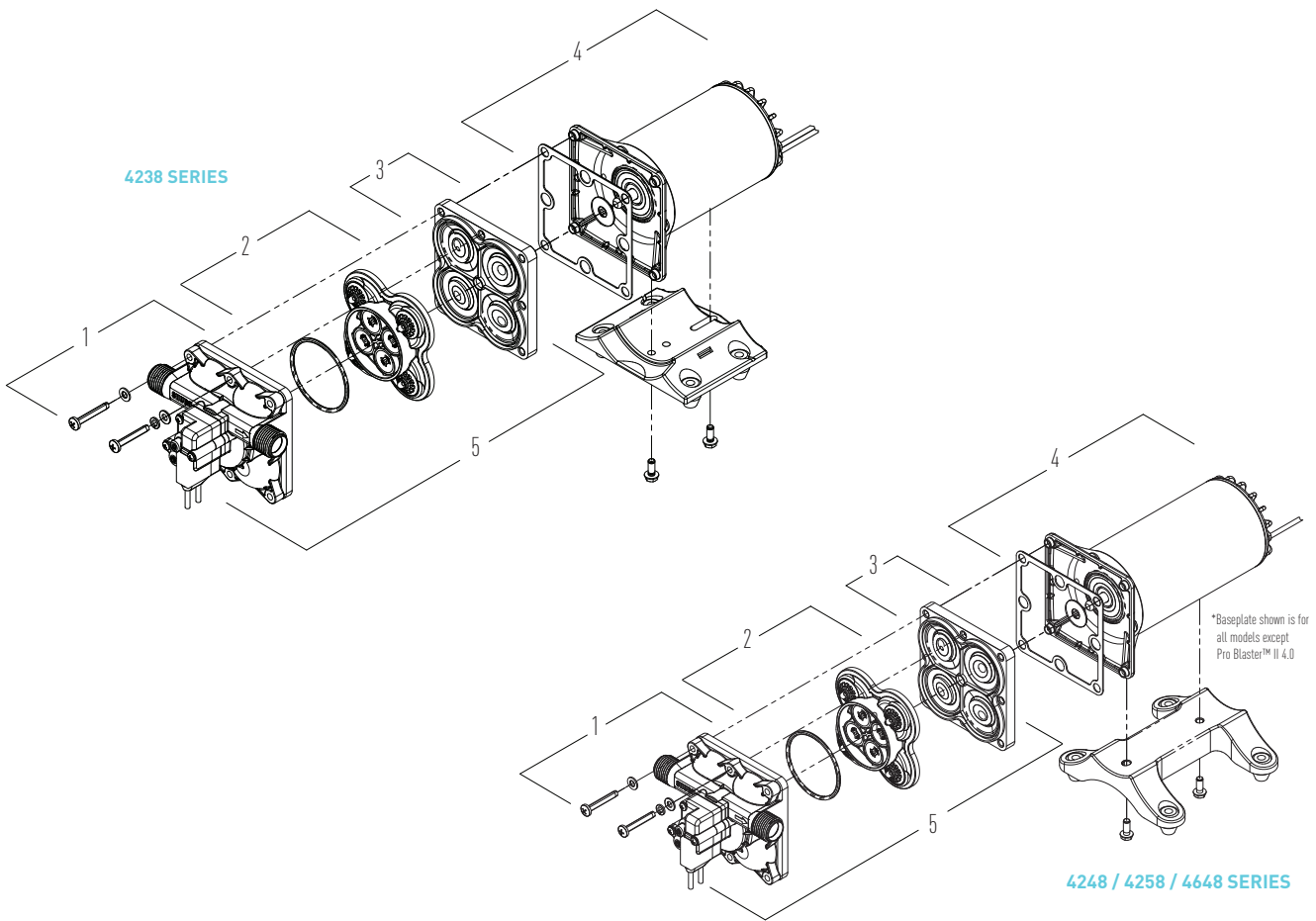

## 4248 / 4258 / 4648 SERIES

Name	OEM Model # (Aftermarket)	Upper Assembly	Valve Assembly	Drive Assembly	Motor & Gasket	Pump Head	Check Valve (Not Shown)
		1	2	3	4	5	6
Pro Blaster™ II Deluxe 4.0	4248-153-A09 [4248-153-E09]	94-804-02	94-800-01	94-801-02	94-71-001-07	94-804-03	94-800-03
Pro Blaster™ II Deluxe 4.0 24 VDC	4248-163-A09 [4248-163-E09]	94-804-02	94-800-01	94-801-02	94-71-001-03	94-804-03	94-800-03
Pro Blaster™ II Ultimate 5.0	4258-153-A09 [4258-153-E09]	94-804-02	94-800-01	94-801-02	94-71-004-17	94-804-03	94-800-03
Pro Blaster™ II Ultimate 5.0 24 VDC	4258-163-A09 [4258-163-E09]	94-804-02	94-800-01	94-801-02	94-71-001-04	94-804-03	94-800-03
Pro BaitMaster™ II 4.0	4648-153-A07 [4648-153-E07]	94-805-01	94-800-01	94-801-02	94-71-001-07	94-805-02	94-800-03
Pro BaitMaster™ II 4.0 24 VDC	4648-163-A07 [4648-163-E07]	94-805-01	94-800-01	94-801-02	94-71-001-03	94-805-02	94-800-03

## 4901 SERIES

Name	OEM Model # (Aftermarket)	Switch	Upper Housing	Valve Assembly	Drive Assembly**	Motor
		1	2	3	4	5
Aqua King™ Premium 45 PSI (3.1 Bar)	4901-4202 [4901-4212]	94-668-00	94-670-01	94-669-00	94-670-00	94-77-013-17
Aqua King™ Premium 30 PSI (2.1 Bar)	4901-4205 [4901-4215]	94-668-01	94-670-01	94-669-00	94-670-00	94-77-013-17
Pro Blaster™	4901-4292 [4901-4282]	94-668-00	94-670-01	94-669-00	94-670-00	94-77-028-17
Pro Blaster™ 24 VDC	4901-5292 [4901-6212]	94-668-00	94-670-01	94-669-00	94-670-00	94-77-025-17
Smart Sensor™ 4.0 12 VDC	4901-0201 [4901-0211]	—	94-670-01	94-669-00	94-670-00	—
Smart Sensor™ 4.0 24 VDC	4901-1201 [4901-1211]	—	94-670-01	94-669-00	94-670-00	—

\*\* For use on pumps manufactured June 2006 or later.

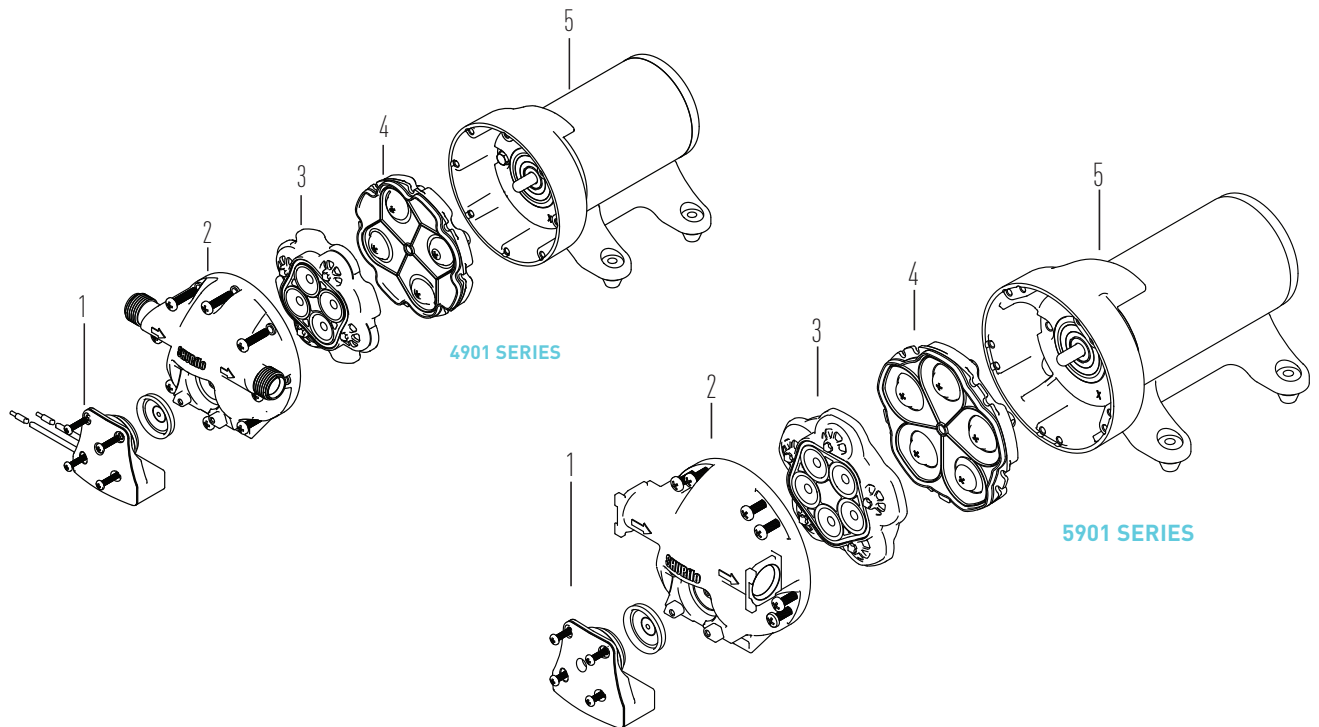

## 5901 SERIES

Name	OEM Model # (Aftermarket)	Switch	Upper Housing	Valve Assembly	Drive Assembly**	Motor
		1	2	3	4	5
Smart Sensor™ 5.7	5901-0201 [5901-0211]	—	94-670-02	94-030-01	94-030-02	—
Smart Sensor™ 5.7 24 VDC	5901-1201 [5901-1211]	—	94-670-02	94-030-01	94-030-02	—
Extreme™ ProBlaster™ 12 VDC	5901-2202 [5901-2212]	94-069-00	94-670-02	94-030-01	94-030-02	94-77-007-17
Extreme™ ProBlaster™ 24 VDC	5901-3202 [5901-3212]	94-069-00	94-670-02	94-030-01	94-030-02	94-77-009-17
Extreme™ ProBlaster™ 32 VDC	5901-4202 [5901-4212]	94-069-00	94-670-02	94-030-01	94-030-02	94-77-010-17

\*\* For use on pumps manufactured June 2006 or later.

# PUMP REPAIR AND REBUILD KITS

## 8050 SERIES

Name	OEM Model # [Aftermarket]	Pumphead Repair Kit	Switch	Check Valve	Upper Housing	Valve Assembly	Drive Assembly
		1	2	3	4	5	6
Utility Pumps	8050-305-XXX [8050-305-XXX]	—	—	—	—	94-391-12	94-385-42

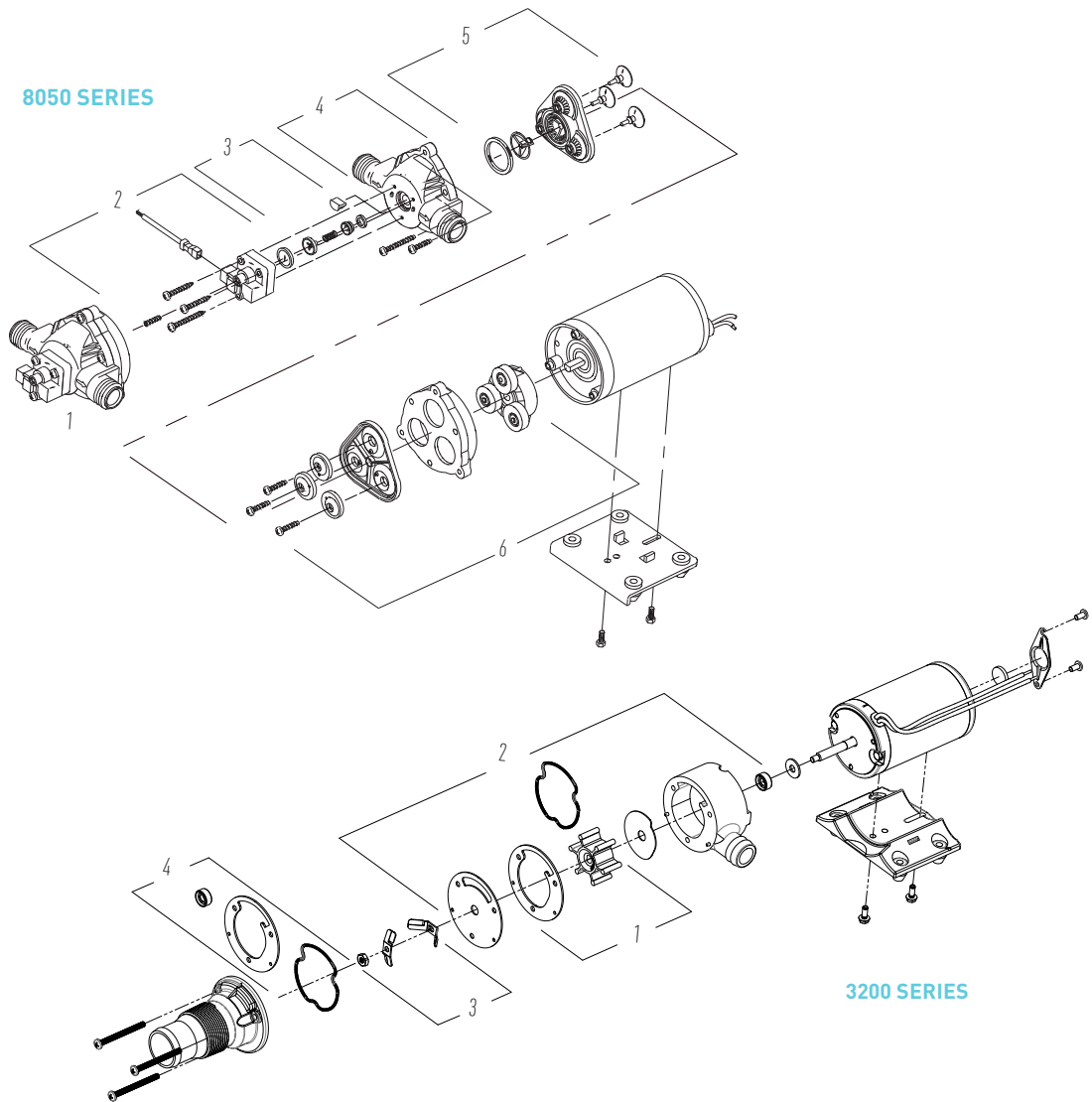

## 3200 SERIES

Name	OEM Model # [Aftermarket]	Impeller Kit	Impeller Housing Kit	Blade Kit	Lip Seal Kit
		1	2	3	4
Macerator 12 VDC	3200-000 [3200-001]	94-571-00	94-570-00	94-570-02	94-570-04
Macerator 12 VDC 180 Degree Port	3200-100 [3200-101]	94-571-00	94-570-00	94-570-02	94-570-04
Macerator 24 VDC	3200-010 [3200-011]	94-571-00	94-570-00	94-570-02	94-570-04
Macerator 24 VDC 180 Degree Port	3200-110 [3200-111]	94-571-00	94-570-00	94-570-02	94-570-04

# INSTALLATION GUIDELINES

## FRESH WATER MULTI-FIXTURE SYSTEMS

The pump may be mounted up to six vertical feet above the water source. Wiring should be switched as well as fused with the recommended size fuse. The inlet side of all fresh water pumps should include the use of a Shurflo strainer. Mount the pump in an accessible area for strainer inspection. Refer to Application and Specification Chart for individual pump recommended wire and fuse sizes.

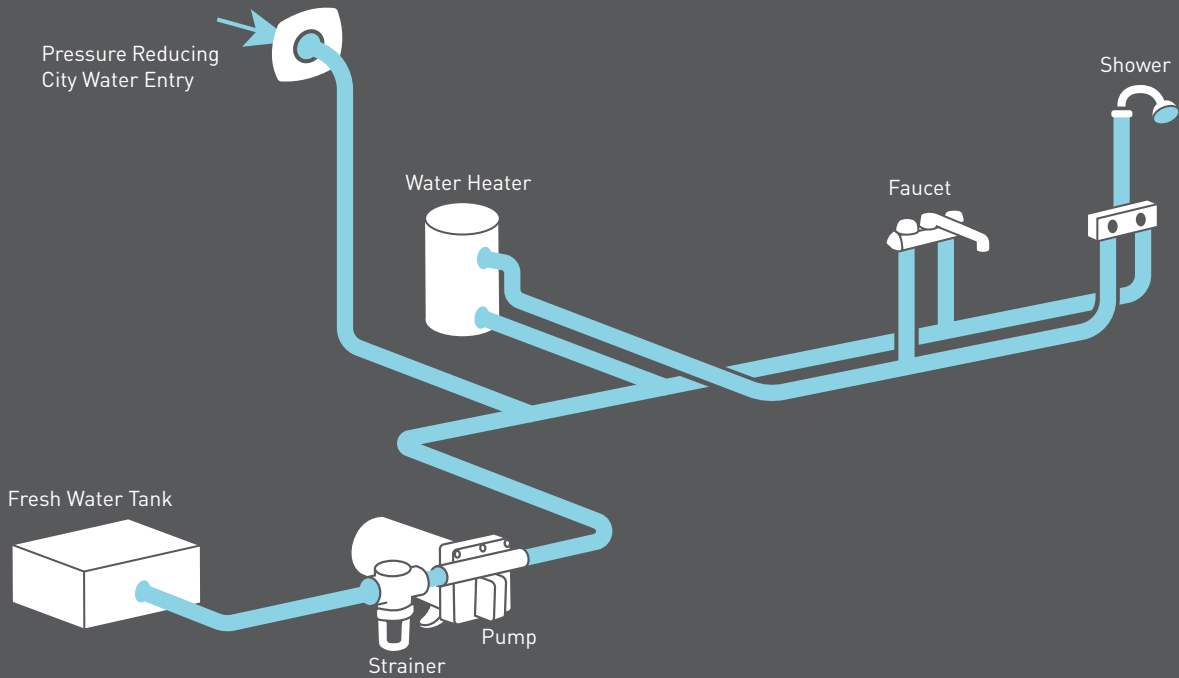

## WASHDOWN SYSTEMS

For washdown systems using the Blaster™/Blaster™ II/Pro Blaster™/Pro Blaster™ II, Shurflo recommends marine approved reinforced hose. For optimum performance, an inlet Shurflo Raw Water Strainer is required. Use of the supplied hose nozzle will insure high pressure delivery. Refer to the Full Line Application and Specification Chart for individual pump recommended wire and fuse sizes.

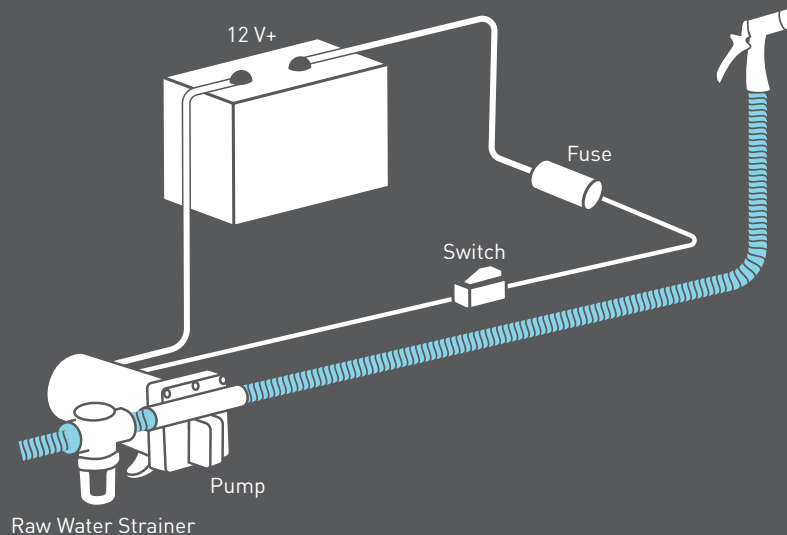

# INSTALLATION GUIDELINES

## LIVEWELL PUMP SYSTEMS

For livewell systems, Shurflo recommends marine approved reinforced hose. Always use double stainless steel clamps for plumbing below the water line. A sea-cock valve must be installed between the pump and the thru-hull fitting. Pump impeller must be below the water line. To prevent an airlock situation, do not allow outlet tubing to sag between pump and tank. Discharge port on pump must be pointed up toward tank, not down towards keel.

When plumbing the livewell pump to a washdown pump, use a Raw Water Strainer between the livewell pump and the washdown pump. Tubing should be no smaller than 1/2" [13mm] marine approved reinforced tubing. Refer to the Shurflo installation manual for complete guidelines.

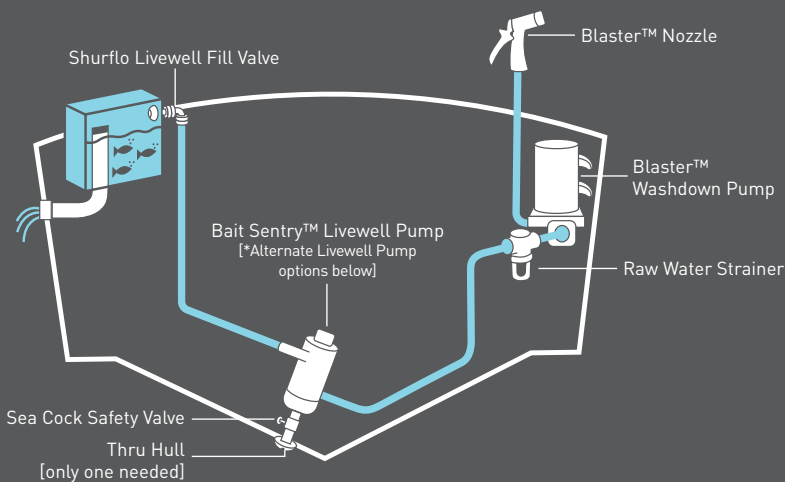

## PRO BAITMASTER™ II LIVEWELL PUMP SYSTEMS

For livewell systems using the Pro Baitmaster™/Pro Baitmaster™ II, Shurflo recommends marine approved reinforced hose. Use 1/2" [13mm] I.D. hose on tank inlet and outlet for minimum back pressure and turbulence to the live bait. A Shurflo Raw Water Strainer between the thru-hull fitting and the pump inlet must be used.

Refer to the Full Line Application and Specification Chart for individual pump recommended wire fuse sizes.

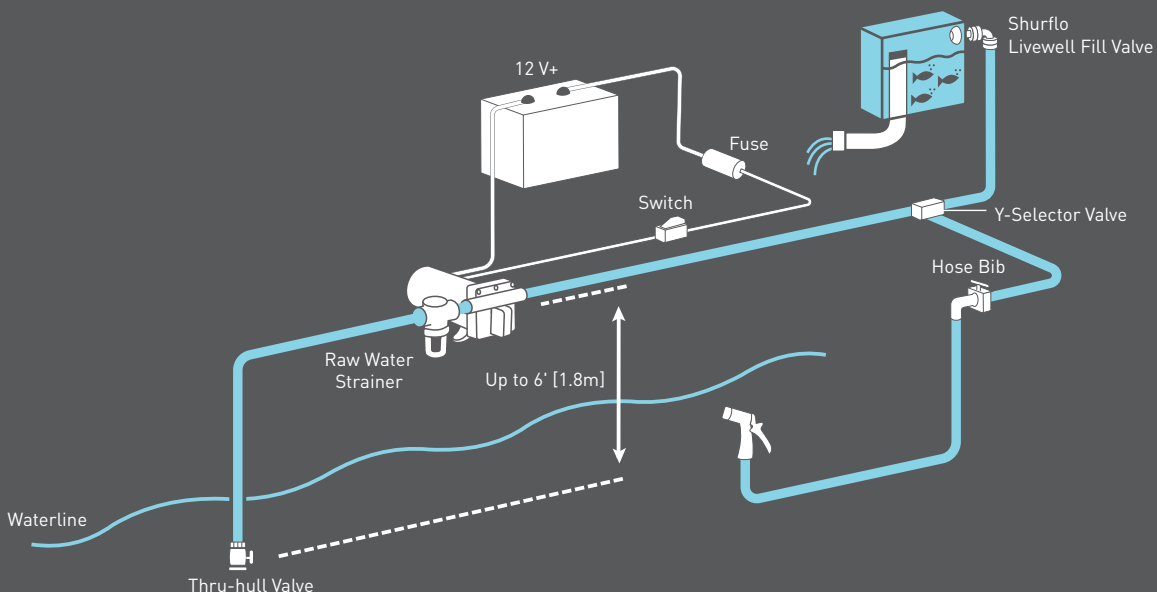



## BILGE PUMPS SYSTEMS

Recommended mounting: attach base to hull or stringer using stainless steel screws. Snap pump into base.

**CAUTION:** Care must be taken not to drive the screws through the hull. Be sure pump is mounted on a flat surface, as low as possible in the bilge.

Attach 3/4" [19mm] (380, 500 & 700 GPH) or 1-1/8" [29mm] (1000 GPH) I.D. smooth bore hose. Use of a smooth bore hose will ensure maximum pump performance. Corrugated hose will significantly reduce pump performance. Route discharge hose to a thru-hull fitting well above the water line. Avoid any sagging or loops in the hose. Vertical lift over 3' [2.1m] significantly reduces output performance. Be sure to check clamp tightness at pump and thru-hull fittings.

**CAUTION:** Do not use open flame in the bilge area. Refer to Full Line Application and Specification Chart for individual pump recommended wire and fuse sizes.

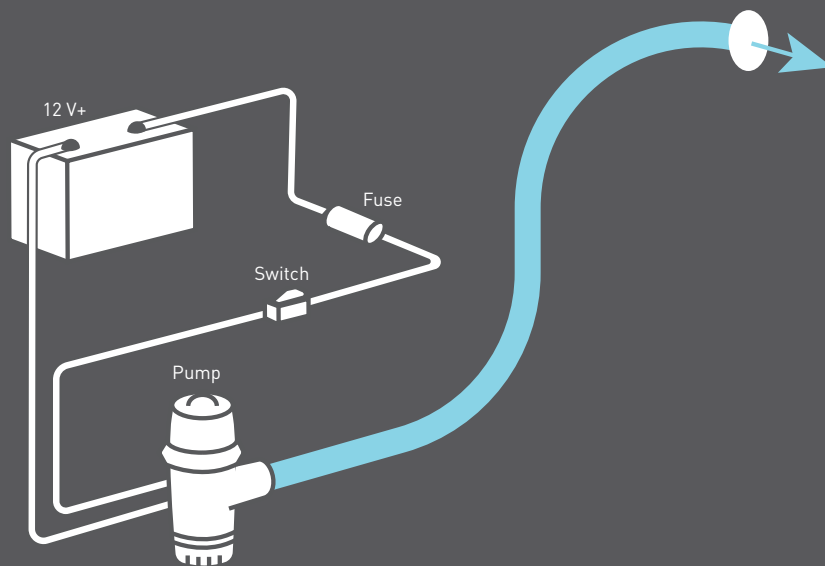

## BLOWER

Shurflo In-Line Blowers provide ventilation for engine compartments, bilges, galleys and head closets. Locate a suitable flat mounting surface on the transom or under the deck. Position blower with flow arrow towards exhaust vent and slightly angled toward engine compartment to avoid moisture build-up. Refer to the Shurflo installation manual for complete guidelines.

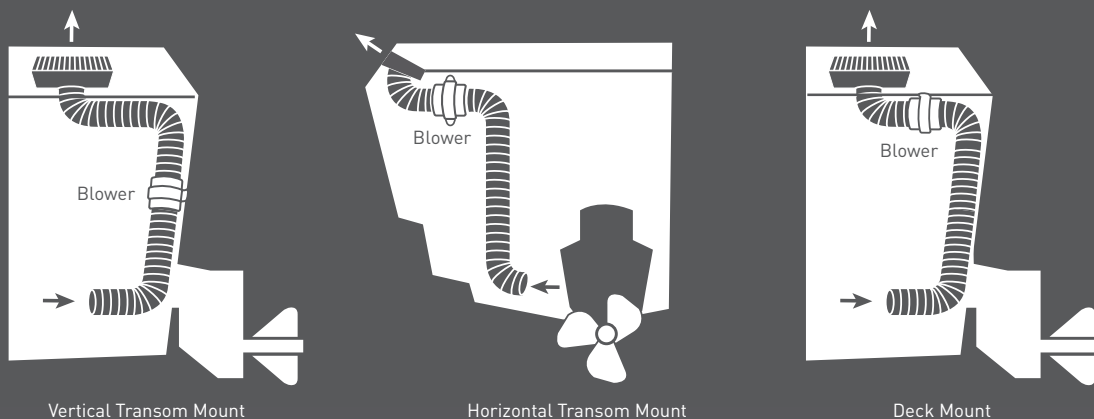

# INSTALLATION GUIDELINES

## MACERATOR SYSTEMS

The Shurflo Macerator pump is designed to empty Marine holding tanks of normal waste. It is also an excellent choice for emptying fish boxes of scales and residual waste. A flow rate of up to 13 gallons per minute conveniently empties any tank in minutes. Refer to the Shurflo installation manual for complete guidelines.

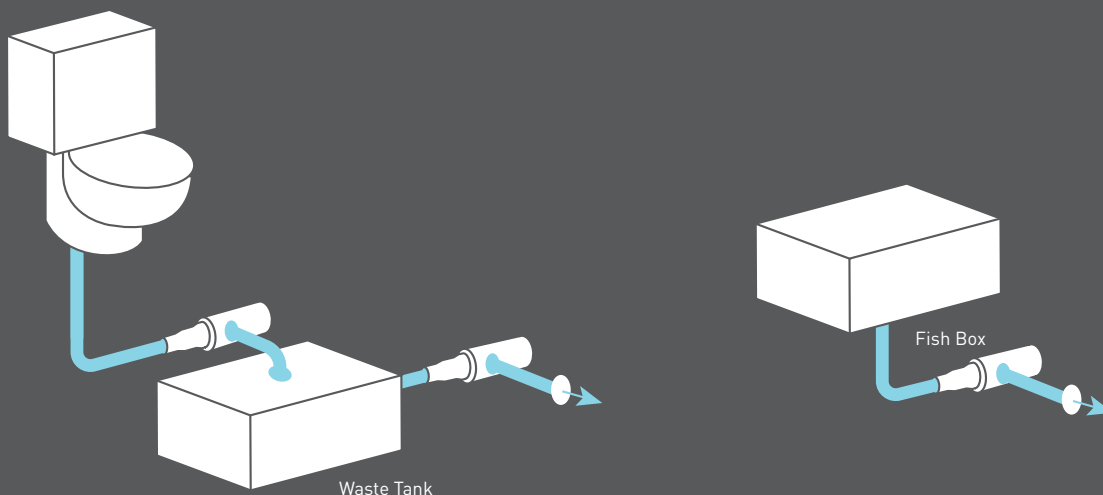

## SHOWER SUMP SYSTEMS

The standard 4138 models can be used for shower sump applications. The sump tray should employ a 6" - 8" trap with adequate strainer capability. Use a Shurflo Raw Water Strainer on the inlet side of the pump, mounted in an easy access location for inspection.

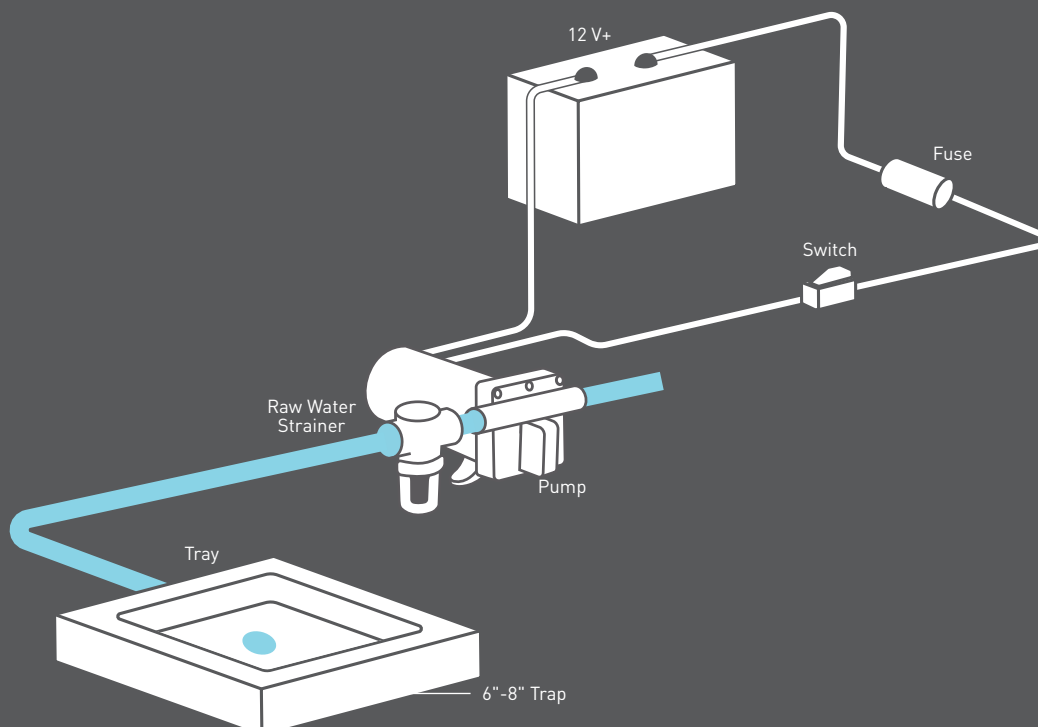

This brief installation guide for Shurflo pump systems will answer the most often encountered questions about basic marine plumbing systems. More detailed information is available through technical data sheets from Shurflo, as well as the installation instruction sheets provided with each product.

**For more information, contact your Shurflo representative or Shurflo customer service toll free at: (800) 854-3218**

## GENERAL NOTES

- All Shurflo marine water pumps are ignition protected.††
- In order to minimize heat rise, continuously operating pumps other than bilge pumps should be mounted in well ventilated spaces.
- Shurflo diaphragm pumps will operate in any position; however, the recommended position is motor up/pumphead down to prevent any possible water damage to the motor in the event of a leak during setup or operation. Mount on a solid surface to reduce noise and vibration.
- Shurflo offers a variety of barbed and threaded fittings in straights and elbows from sizes 3/8" to 3/4".
- All Shurflo 4XX8 threaded pump ports are internally tapered, to be thoroughly hand-tightened only with Shurflo swivel fittings. They eliminate expensive brass or stainless fittings which require more complex plumbing.
- A safety sea-cock (thru-hull valve) is required for any installation using a thru-hull water source.
- In accordance with American Boat and Yacht Council (ABYC) guidelines, the recommended placement for all diaphragm pumps plumbed to a thru-hull fitting is above the waterline.
- The self-priming feature of Shurflo diaphragm pumps allows them to be mounted any distance up to 30 feet [9.2m] horizontal from on-board water supplies, insuring easy access to plumbing connections and strainers, maximizing reduction of noise or vibration and minimizing exposure to splashed water.
- All Shurflo pumps are engineered with rubber mounting feet to minimize noise and vibration and will function properly only if proper fasteners are used to snug down (not flatten) the feet. Flexible inlet and outlet plumbing (such as reinforced hose), is critical to lower pump noise level and increase pump life.
- Shurflo recommends that all pumps be fused individually, in addition to any other circuit protection used such as circuit breakers.
- Waterguard™, Pentair® and Everpure® filters are great for Marine applications. The filter may be installed in any convenient location. Be sure to keep the filter away from any heat source. All filters should be replaced seasonally (6-12 months) or when taste and odor problems return.

## WIRE SIZE REQUIREMENTS [Based on 10 Amps; 10% voltage drop]

Battery-to-pump distance	AWG [mm <sup>2</sup> ]
0-25 feet [0-7.6m]	16 [1.3]
25-50 feet [7.6-15.2m]	14 [2.1]
50-70 feet [15.2-21.3m]	12 [3.3]
70-110 feet [21.3-33.5m]	10 [5.3]

Minimum wire size for a 10% voltage drop on a 12VDC, 10 Amp Circuit. Length is the distance from the power source to pump and back to ground.

†(1/2" - 14 National American Straight Pipe Thread)  
 ††(Except 8050-305-626 & 8050-305-426)

## PLUMBING GUIDELINES [For long life and low noise]

Area	Suggestion
Shurflo Fittings	Hand tighten only.
Feet	Snug, don't flatten; solid surface
Pump/Hose	Flexible hose on inlet and outlet side of pump. 1/2" minimum on mains, 3/8" minimum on branch.
Water Purifier	Run separate line from mains. 1/4" minimum recommended.
Noise Reduction	Use flexible hose. Check for air in system, including all drain lines and hot water heater lines.



#### **USA**

3545 Harbor Gateway South, Suite 103  
Costa Mesa, CA, 92626, USA  
800-854-3218 [www.shurflo.com](http://www.shurflo.com)

#### **EUROPE**

Pentair® Water Belgium B.V.B.A. Industriepark Wolstee,  
Toekomstlaan 30 2200 Herentals, Belgium  
Tel: +32 14 259 911 Fax: +32 14 259 975  
[shurflo.service@pentair.com](mailto:shurflo.service@pentair.com)

#### **CENTRAL & SOUTH AMERICA**

Pentair Water do Brasil LTDA.  
Av. Marginal Norte da Via Anhanguera,  
53.700 – Jundiaí/SP – Brasil – CEP: 13206-245  
Tel: (11) 3378-5400  
E-mail: [vendas.pwdb@pentair.com](mailto:vendas.pwdb@pentair.com)

All Pentair trademarks and logos are owned by Pentair, Inc. All other brand or product names are trademarks or registered marks of their respective owners. Because we are continuously improving our products and services, Pentair reserves the right to change specifications without prior notice. Pentair is an equal opportunity employer.