

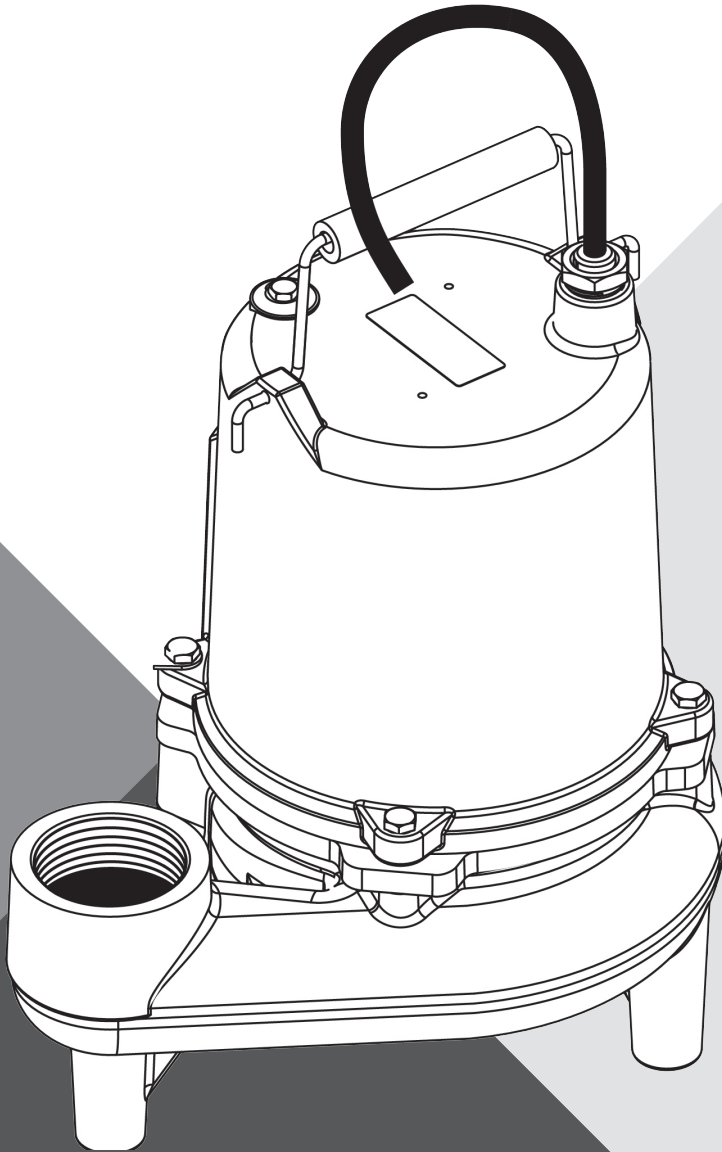

SUBMERSIBLE SEWAGE EJECTOR PUMP MSKV50



INSTALLATION AND OPERATION MANUAL

pentair.com

TABLE OF CONTENTS

General Safety	3
Installation.....	4
Maintenance And Service.....	5
Parts List	7
Warranty.....	8

GENERAL SAFETY

IMPORTANT SAFETY INSTRUCTIONS

This manual contains important instructions that should be followed during installation, operation, and maintenance of the product.

 This is the safety alert symbol. When you see this symbol on your pump or in this manual, look for one of the following signal words and be alert to the potential for personal injury!

 **DANGER** indicates a hazard which, if not avoided, will result in death or serious injury.

 **WARNING** indicates a hazard which, if not avoided, can result in death or serious injury.

 **CAUTION** indicates a hazard which, if not avoided, can or may result in minor or moderate injury.

NOTICE: addresses practices not related to personal injury.

Carefully read and follow all safety instructions in this manual and on pumps. Keep safety labels in good condition. Replace missing or damaged safety labels.

 **WARNING** Battery acid is corrosive. Do not spill on skin, clothing, or battery charger. Wear eye and head protection when working with battery. Connect and disconnect DC output terminals only after removing the charger from the AC outlet. Never allow the DC terminals to touch each other.

 **WARNING** Hazardous Voltage. Can cause severe or fatal electrical shock. Do not plug in or unplug battery charger while standing on a wet floor or in water. Be sure one hand is free when plugging in or unplugging charger. If basement floor is wet, disconnect power to basement before walking on floor. If shut-off box is in basement, call electric company or hydro authority to shut-off service to house, or call your local fire department for instructions. Remove pump and repair or replace. Failure to follow this warning can result in fatal electrical shock.

 **CAUTION** Risk of flooding. Do not run pump dry. To do so will damage seals and can cause leaking and property damage.

 **WARNING** Risk of electrical shock. Do not lift the pump by the electrical cord; lift pump only by the discharge pipe, lifting ring or handle on the pump. Lifting by the cord can damage the cord.

CALIFORNIA PROPOSITION 65 WARNING

 **WARNING** This product and related accessories contain chemicals known to the State of California to cause cancer, birth defects or other reproductive harm.

GENERAL SAFETY

Thank you for purchasing your Myers® pump. To help ensure years of trouble-free operation, please read the following manual carefully.

BEFORE OPERATION

Read the following instructions carefully. Reasonable care and safe methods should be practiced. Check local codes and requirements before installation.

Attention: This manual contains important information for the safe use of this product. Read this manual completely before using this product and refer to it often for continued safe product use. **DO NOT THROW AWAY OR LOSE THIS MANUAL.** Keep it in a safe place so that you may refer to it often.

Warning: Before handling these pumps and controls, always disconnect the power first. Do not smoke or use sparkable electrical devices or flames in a septic (gaseous) or possible septic sump.

PUMP WARNING

To reduce risk of electrical shock:

1. Risk of Electrical Shock: This pump has not been investigated for use in swimming pool areas.
2. Risk of Electrical Shock: Connect only to a properly grounded receptacle. Septic tank to be vented in accordance with local plumbing codes.

Do not smoke or use sparkable electrical devices or flame in a septic (gaseous) or possible septic sump.

If a septic sump condition exists and if entry into sump is necessary, then (1) provide proper safety precautions per OSHA requirements and (2) do not enter sump until these precautions are strictly adhered to.

Do not install pump in location classified as hazardous per N.E.C., ANSI/NFPA 70 - 2001.

INSTALLATION

These important instructions must be followed for satisfactory performance of your pump. Before installation, check your local electrical and plumbing codes.

1. Provide proper sump size to allow the pump to operate without restrictions. A two- to five-minute run time is recommended. Also, minimum 24" diameter recommended.
2. Make sure sump is free of string, cloth, nails, gravel, etc. before installing pump.
3. Do not set pump directly on the bottom of sump pit if it is not solid. Raise the pump by placing bricks or concrete blocks underneath it.
4. Use steel or plastic pipe for all connecting lines between pump and sewer outlet.

NOTE: Some city regulations do not allow installing a pump with plastic pipe. Check local regulations.

5. In applications where the pump may sit idle for months at a time, it is recommended that the pump(s) be cycled every month to ensure the pumping system is working properly when needed.
6. A check valve should be installed in discharge pipe, at least 12" above the discharge outlet of the pump.
7. An audible alarm system for high water conditions should be installed in every pump for greater protection.

NOTE: Alarm is for indoor use only. Contact your Myers distributor for other panel applications.

WARNING: When using the automatic diaphragm switch the vent tube in the plug must be clear of obstructions.

Do not bend cord. This will cause a crimp in the vent tube and switch failure will occur. Pump should be plugged into a single outlet, where vent tube can "breathe." Blocking tube or bending cord will void the warranty.

8. Connect to power source using 3-prong grounded AC receptacle. Do not remove ground pin from electrical plug. Do not use an extension cord.
9. For proper automatic operation (MSKV50AD and MSKV50AW) make sure the pump power cord is plugged into the back of the piggyback receptacle on the float switch cord.
10. Use pump partially or completely submerged for pumping (temperature to 140° F). The MSKV50 will pump solid materials up to 2" (spherical) in diameter.



MSKV50 Typical Installation

MAINTENANCE AND SERVICE

PUMP SERVICING

Servicing should be performed only by knowledgeable pump service contractors or authorized service stations.

1. Remove pump from sump. Before removing pump from sump pit for repair, check if the trouble could simply be a blown fuse, tripped circuit breaker, or a power cord not completely inserted into the receptacle.
2. Check diaphragm switch. If the unit is being operated by the automatic diaphragm switch, unplug the pump from the piggyback receptacle and plug the pump directly into the power source. If the pump starts each time it is plugged directly into the receptacle and does not start each time when plugged into the piggyback switch with the diaphragm switch pressed into a start position, replace the complete piggyback switch assembly and retest with new assembly.
3. Check for impeller blockage. Disconnect pump and switch from power source. Check for an obstruction in the impeller cavity by laying the pump on its side and inserting a screwdriver into impeller. Impeller should turn freely. If impeller is stuck, then turn the pump on its side, **DRAIN THE OIL** through the oil fill plug on top of the pump. Drain oil into a clean, dry container. A milky appearance to the oil indicates that water has entered through either worn out or damaged seals (7) or seal ring. Remove the 4 screws (6) to remove the volute (9). If the impeller (10) does not rotate freely, clear the impeller and cavity walls before reassembling the base. Repeat Step 2.
4. Check power cord. If the above tests have not resolved the problem, it may be in the electrical components of the pump. Starting with the power cord (2), inspect for cuts or nicks in the insulation. If the cord is damaged – replace it!
5. Remove the motor cover. Use a screwdriver to pry the motor cover (3) from the seal plate (8) at the fastening ears, being careful not to cut the seal ring with the screwdriver or crack the motor cover. Lift the motor cover until it clears the stator (4).

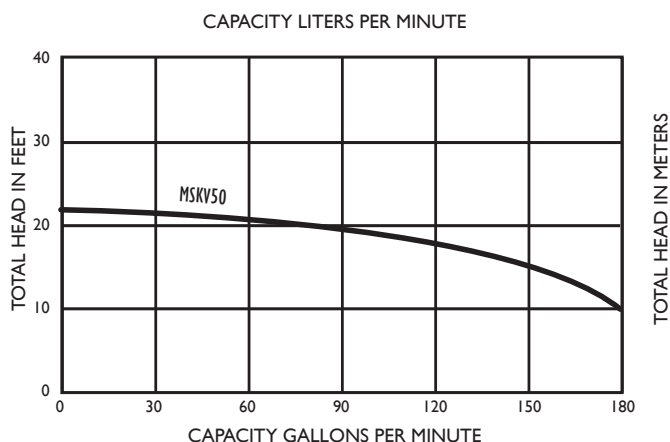

6. Check for short. Disconnect the stator leads from the connector. Use an ohmmeter to check the continuity of the stator. If stator fails to pass the continuity test, it must be replaced.

Ground check. Set ohmmeter scale pointer to R X 100K scale and check meter by putting both meter leads together and adjusting the needle knob until meter reads zero. If meter cannot be adjusted to zero it will indicate that batteries in meter must be replaced.

Always make this test with the meter when scale pointer is set to a new scale before making any checks on motor.

Now connect one meter lead to one blade terminal of stator and touch other meter lead to motor stator shell (4). If needle reads below 5 (500,000 ohms) stator must be dried out before reusing. To dry out, bake in 220° oven for 4 hours. Recheck after motor cools. If motor is new or thoroughly dry, needle of ohmmeter will not move on the ground test. This indicates a reading of 50 megohms or higher. One megohm is one million ohms.

When making the ground test, if the needle goes clear to zero the motor probably has a wire touching the stator at some point and the stator will have to be replaced.

Winding resistance test. If motor shows a satisfactory ground test, then the winding resistance must be checked. Use ohmmeter with scale pointer set on R X 1 scale. On this scale meter reads directly on ohms. Always check the meter with leads together as described above under ground test before making a reading of the winding.

Connect one meter lead to each of the black terminal leads. Meter should read about 1.35 ohms. This is the resistance of the main winding for a 115 volt stator. This reading for a 230 volt stator should be about 6.22 ohms.

Now remove the capacitor and connect one meter lead to each of the brown wire terminals. The meter should read about 11.35 ohms for a 115 volt stator. For a 230 volt stator this reading should be 32.4 ohms. This is the resistance of the start winding.

7. Remove the stator. To remove the stator, remove the four hex head screws and disconnect the brown capacitor leads from the capacitor and remove the stator plate with the capacitor. Lift the stator off the seal plate (8) and set aside.
8. Remove the impeller. To remove the impeller (10), hold the motor shaft (5) with a screwdriver at the center of the impeller and tap the impeller with a plastic or rubber mallet so as to turn the impeller counterclockwise.

MAINTENANCE AND SERVICE

9. Check the seal. Remove the rotating portion of seal (6) from shaft by inserting a screwdriver under the edge of the seal and lifting it off. Inspect the seal face for any nicks or an uneven seating of seal face. If any are present, replace the seal. (See Step 14.) Remove rotor and shaft. Tap the rotor shaft (5) at the impeller end of the shaft with a plastic mallet to remove the rotor and shaft. Inspect the bearings. If they do not rotate freely and smoothly, they should be replaced.
10. Remove rotor and shaft. Tap the rotor shaft (5) at the impeller end of the shaft with a plastic mallet to remove the rotor and shaft. Inspect the bearings. If they do not rotate freely and smoothly, they should be replaced.
11. Remove seal. Remove the old stationary portion of the seal (7) from the seal plate by inserting a screwdriver into the seal housing of the seal plate from the top of the case and tapping lightly with a hammer. Clean the seal area of the seal plate (8) with a clean cloth.
12. Reinstall the rotor and shaft assembly. Push on outer face to seat bearing in seal plate.
13. Reinstall seal. Apply a good lubricant to the new stationary portion of the seal (7) and press into the seal plate. Coat the new rotating portion of seal with lubricant and press into place on the rotor shaft with the rubber ring facing the impeller.
14. Reinstall impeller. Add a drop of Loctite 222 to the shaft and screw the impeller on hand tight. The impeller will force the rotating portion of seal into position.
15. Replace seal ring. Remove the old square seal ring from the seal plate and stretch on a new ring coated with O-ring lube. Do not roll the ring onto the seal plate or improper seating and water leakage into the motor housing will result.
16. Reinstall the stator. Place the stator (4) in the seal plate (8) so the stator bolt holes line up. Lay the stator plate on the stator (4) and line up with stator bolt holes. Put in the stator bolts and tighten evenly to prevent cocking of the stator.

Connect the capacitor to the capacitor leads. Push the connectors of the two black stator leads onto the power cord spade terminals.

17. Reassemble pump. Replace the motor cover (3) on the seal plate (8). Place the assembly on the volute (9). Insert the four cap screws (6) through the motor housing ears, into the tapped holes in the volute. Tighten them evenly to prevent cocking the motor housing and causing an uneven seal on the seal ring.

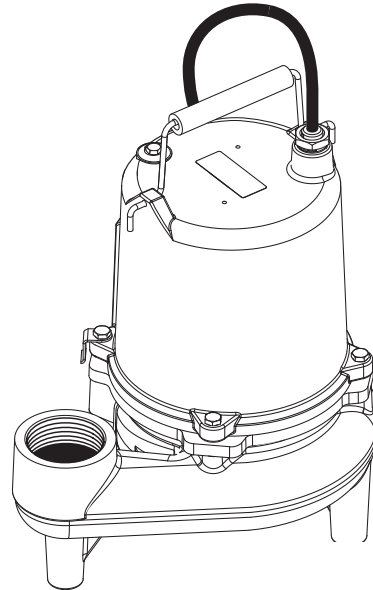

18. Oil. Fill the motor cap with high grade transformer oil just covering over stator end cap (.45 gallon).
19. Do not fill the motor housing completely – allow airspace for oil expansion. Make sure the stator and capacitor are fully immersed. You will have to peer through the oil plug hole to be sure of the correct oil level.

Model Number	Motor HP	Feet (meters)	Volts	Phase	Max Load Amps	Individual Branch Circuit Required (Amps)	Discharge Adapter Size (inches)	Switch Setting in inches (mm)	
								On	Off
MSKV50AD110	1/2	10 (3.1)	115	1	12	15	2	12.25 (31.1)	3.75 (9.5)
MSKV50AD120	1/2	20 (6.1)	115	1	12	15	2	12.25 (31.1)	3.75 (9.5)
MSKV50AW110	1/2	10 (3.1)	115	1	12	15	2	14 (35.6)	7.5 (19.1)
MSKV50AW120	1/2	20 (6.1)	115	1	12	15	2	14 (35.6)	7.5 (19.1)
MSKV50M110	1/2	10 (3.1)	115	1	12	15	2	-	-
MSKV50M120	1/2	20 (6.1)	115	1	12	15	2	-	-
MSKV50M220	1/2	20 (6.1)	230	1	6	10	2	-	-

PARTS LIST

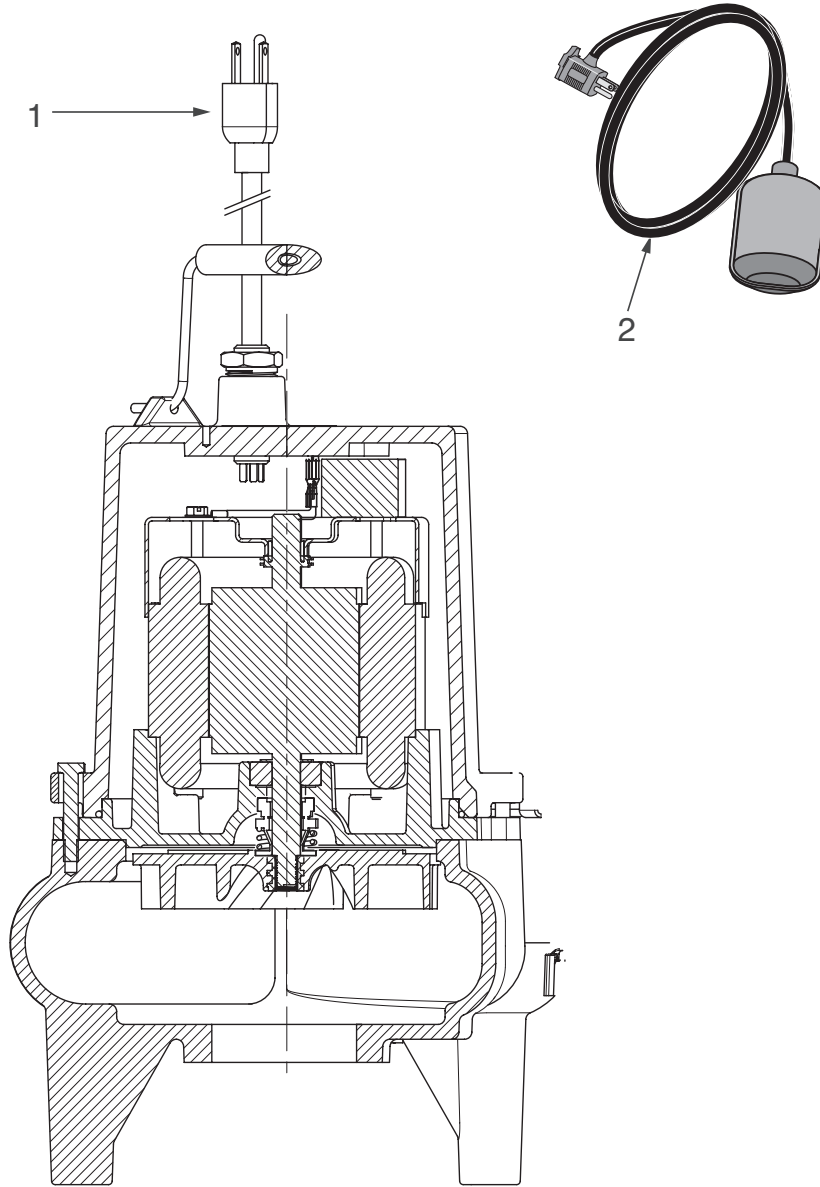

MODEL - MSKV50									
Key No.	Description	Quantity	MSKV50AD110	MSKV50AD120	MSKV50AW110	MSKV50AW120	MSKV50M110	MSKV50M120	MSKV50M220
1	Cord 115V 10'(3.1m)	1	146230101		146230101		146230101		
1	Cord 115V 20'(6.1m)	1		146230201		146230201		146230201	
1	Cord 230V 20'(6.1m)	1							146232201
2	Piggyback Tethered Float Switch 115V 10'(3.1m)	1			145951101				
2	Piggyback Tethered Float Switch 115V 20'(6.1m)	1				145951201			
3	115V 10' Diaphragm Switch	1	DPS81 10						
3	115V 20' Diaphragm Switch	1		DPS81 20					

WARRANTY

Limited Warranty

Myers warrants to the original consumer purchaser ("Purchaser" or "You") of the products listed below, that they will be free from defects in material and workmanship for the Warranty Period shown below.

Product	Warranty Period whichever occurs first:
Jet pumps, small centrifugal pumps, submersible pumps and related accessories	12 months from date of original installation, or 18 months from date of manufacture
Fibrewound Tanks	5 years from date of original installation
Steel Pressure Tanks	5 years from date of original installation
Sump/Sewage/Effluent/Utility/Battery Backup Products	36 months from date of manufacture
Wastewater Solids Handling Pumps	12 months from date of shipment from factory or 18 months from date of manufacture

Our warranty applies **only** where such products are used in compliance with the requirements of the applicable product catalog and/or manuals. For additional information, please refer to the applicable standard limited warranty featured in the product manual.

Our warranty will **not** apply to any product that, in our sole judgment, has been subject to negligence, misapplication, improper installation, or improper maintenance. Without limiting the foregoing, operating a three phase motor with single phase power through a phase converter will void the warranty. Note also that three phase motors must be protected by three-leg, ambient compensated, extra-quick trip overload relays of the recommended size or the warranty is void.

Your only remedy, and MYERS's only duty, is that MYERS repair or replace defective products (at MYERS's choice). You must pay all labor and shipping charges associated with this warranty and must request warranty service through the installing dealer as soon as a problem is discovered. No request for service will be accepted if received after the Warranty Period has expired. This warranty is not transferable.

MYERS SHALL NOT BE LIABLE FOR ANY CONSEQUENTIAL, INCIDENTAL, OR CONTINGENT DAMAGES WHATSOEVER.

THE FOREGOING LIMITED WARRANTIES ARE EXCLUSIVE AND IN LIEU OF ALL OTHER EXPRESS AND IMPLIED WARRANTIES, INCLUDING BUT NOT LIMITED TO IMPLIED WARRANTIES OF MERCHANTABILITY AND FITNESS FOR A PARTICULAR PURPOSE. THE FOREGOING LIMITED WARRANTIES SHALL NOT EXTEND BEYOND THE DURATION PROVIDED HEREIN.

Some states do not allow the exclusion or limitation of incidental or consequential damages or limitations on the duration of an implied warranty, so the above limitations or exclusions may not apply to You. This warranty gives You specific legal rights and You may also have other rights which vary from state to state.

This Limited Warranty is effective January 1, 2021 and replaces all undated warranties and warranties dated before January 1, 2021.

PENTAIR MYERS
293 Wright Street, Delavan, WI 53115
Phone: 888-987-8677 • Fax: 800-426-9446 • www.femyers.com
In Canada: 490 Pinebush Road, Unit 4, Cambridge, Ontario N1T 0A5
Phone: 800-363-7867 • Fax: 888-606-5484



US: 293 WRIGHT ST
DELAVAN, WI 53115
Phone: 800-365-6832
Fax: 800-526-3757

pentair.com