

# SEWAGE EJECTOR PUMP & BASIN PACKAGE

## M224A MODEL

The Myers M224A Model Sewage Ejector Pump & Basin Package is specifically designed to meet the demands of residential wastewater and sewage applications. It includes the MSKV50AW1 1/2 HP pump constructed from heavy duty cast iron with an oil-filled motor for cooler operation, permanent lubrication of the bearings, and a longer, trouble-free pump life.

The MSKV50AW1 features a wide-angle piggyback float switch for reliable automatic operation. All of which is packaged within the super strong poly basin that is nestable, impact resistant, and corrosion proof. The basin comes complete with all the fittings, schedule 80 piping, swing check valve, grommets, o-rings, gasket material, and hardware required so the plumber always has the complete package at the job site.

### APPLICATIONS

Sewage, high-capacity sump, and effluent.

### FEATURES

- ◆ Completely assembled package from the factory, ready for quick and easy installation.
- ◆ Structural foam basins are made of durable polyethylene and injection molded single piece construction for consistent quality, lightweight easy handling and installation. No heavy equipment or lifting required.
- ◆ Molded torque stops in basin to prevent pump from moving.
- ◆ Durable 14G steel cover for easy maintenance that allows removal without having to disconnect the vent piping.
- ◆ Several 3/8" threaded inserts are molded in the top flange to fasten the lid on to the tank. This keeps the corrosive gases away and creates a strong unstrippable or unslippable insert.
- ◆ Neoprene gasket tape to attach to the tank lid to get a positive seal between basin and cover.
- ◆ Strong and durable cover protects against abuse during installation, service, and regular daily wear.
- ◆ Piggyback Switch Plug design allows for simple conversion to manual operation by plugging the motor plug directly into the electrical outlet, providing an easy way to periodically cycle the pump to ensure it is operating properly.

### SPECIFICATIONS

- ◆ **Handle:** Stainless steel
- ◆ **Lubricating Oil:** Dielectric oil
- ◆ **Motor Housing:** Cast iron
- ◆ **Seal Plate:** Engineered thermoplastic
- ◆ **Pump Casing:** Cast iron
- ◆ **Shaft:** Stainless steel
- ◆ **Mechanical Shaft Seal:** Seal Faces = carbon/ceramic seal body = brass; Spring = stainless steel; Bellows = Buna-N®
- ◆ **Impeller:** Engineered thermoplastic
- ◆ **Upper Bearing:** Single row ball bearing
- ◆ **Lower Bearing:** Single row ball bearing
- ◆ **Fasteners:** Stainless steel



Tested & Certified to UL778  
and CSA 108.

**3 Year Warranty**

## SEWAGE EJECTOR PUMP & BASIN PACKAGE M224A SYSTEM

### SPECIFICATION DATA

- ◆ **Automatic Models:** MSKV50AW1
- ◆ **Horsepower:** 1/2
- ◆ **Full Load Amps:** 12.0
- ◆ **Motor Type:** PSC
- ◆ **R.P.M.:** 1650
- ◆ **Phase Ø:** 1
- ◆ **Voltage:** 115
- ◆ **Hertz:** 60
- ◆ **Operation:** Intermittent
- ◆ **Temp.:** 140°F
- ◆ **NEMA Design:** L
- ◆ **Insulation:** Class B
- ◆ **Discharge Size:** 2" NPT std.
- ◆ **Solids Handling:** 2"
- ◆ **Unit Weight:** 76 lbs.
- ◆ **Power Cord:** 16/3, 115V = 10' std

#### BASIN:

- ◆ Capacity 65 U.S. Gallons
- ◆ Poly
- ◆ Impact Resistant
- ◆ Corrosion Proof
- ◆ 4" Inlet hub
- ◆ Weight 15 lbs.

#### FITTINGS:

- ◆ Nitrile Electrical Grommets & O-Rings
- ◆ Optional 2" & 3" Discharge Ring Available
- ◆ 1/2" Wide Neoprene Gasket Tape for Positive Seal
- ◆ 3/8" Plated Hex Head Machine Screws

#### COVER:

- ◆ 14G steel
- ◆ Impact Resistant

### PUMP PERFORMANCE

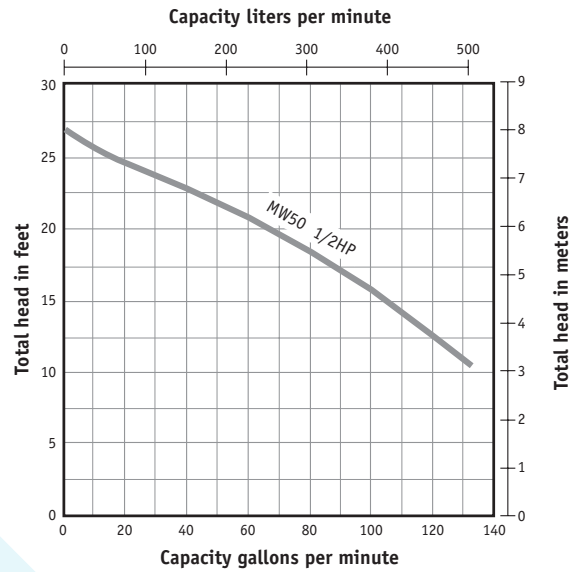

### ORDERING INFORMATION

MODEL NUMBER	HP	MAX CAPACITY	MAX HEAD	DISCHARGE	SOLIDS HANDLING	VOLTS	FULL LOAD AMPS	PHASE	CORD LENGTH	SWITCH
M224A	1/2	180	22	2"	2"	115	12.0	1	10'	PT

**DIMENSIONAL DATA**

SWITCH	DIAPHRAGM	TETHERED
Pump On	12.25 [311.2]	14.00 [355.6]
Pump Off	3.75 [95.3]	7.50 [190.5]

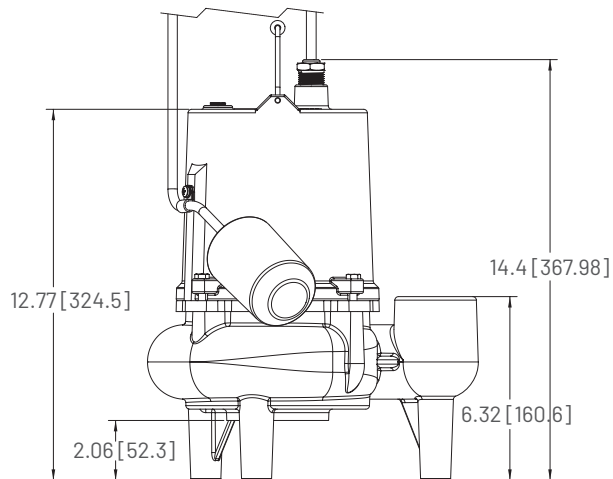
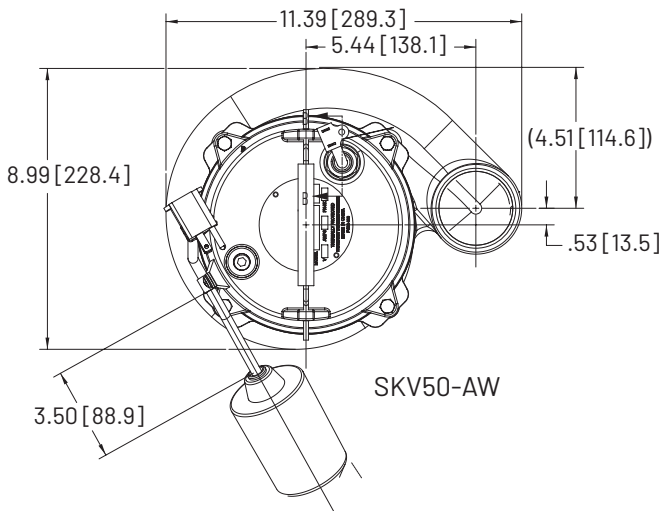

**BASIN DIMENSIONAL DATA**

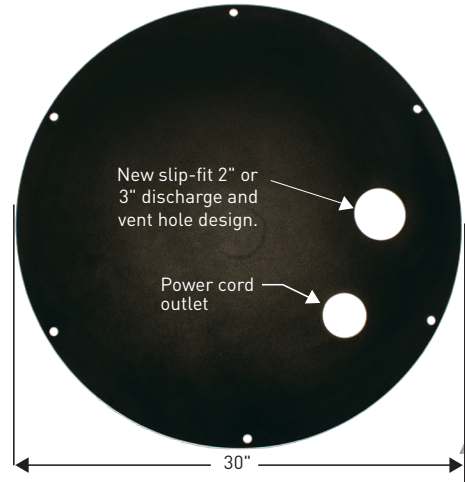

All dimensions in inches. Metric for international use. Component dimensions may vary ± 1/8 inch. Dimensional data not for construction purpose unless certified. Dimensions and weights are approximate. On/Off level adjustable.



293 Wright St  
Delavan, WI 53115  
Ph: 888.987.8677  
Fx: 800.426.9446

490 Pinebush Rd, Unit 4  
Cambridge, Ontario N1T 0A5, Canada  
Ph: 800.363.7867  
Fx: 888.606.5484

pentair.com

All indicated Pentair trademarks and logos are property of Pentair. Third party registered and unregistered trademarks and logos are the property of their respective owners. Because we are continuously improving our products and services, Pentair reserves the right to change specifications without prior notice. Pentair is an equal opportunity employer.

Buna N® is the registered trademark of Pittway Corporation, Chicago, IL.

©2023 Pentair. All Rights Reserved.

M99630SSE (08-01-23)