

SHALLOW WELL JET PUMPS

MPN SERIES

MPN Series Shallow Well Jet Pumps are corrosion and abrasion resistant and are ideal for wells with pumping levels of 25' or less. Self-priming after the pump housing is initially filled with water.

Capacities to 18 GPM at 30 PSI. Available in 1/2, 3/4 and 1 HP models. Supplied with the industry standard 30-50 pressure switch setting.

APPLICATIONS

Water systems such as booster pump, marine, poultry, mist sprayers, fountains, and water features.



FEATURES

- ◆ **Quality Construction:** Fiberglass-reinforced thermoplastic body provides total corrosion resistance and high resistance to abrasion.
- ◆ **Built-in Jet:** Shallow-well jet has corrosion-resistant engineered composite nozzle and venturi.
- ◆ **Impeller:** Precision-molded for perfect balance. Ultra-smooth for highest performance and efficiency.
- ◆ **Precision Molded Diffuser:** Engineered composite diffuser allows pump to prime faster, handle more air.
- ◆ **Heavy Duty Motor:** Stainless steel shaft and dual heavy-duty ball bearings.
- ◆ **Heavy Duty Ball Bearings:** Shielded, permanently lubricated bearings, extensively tested to ensure extended life and smooth, quiet operation.
- ◆ **Dual Voltage Capability:** 1/2, 3/4 and 1 HP models have dual voltage motors and are shipped at 230 Volt setting.
- ◆ **Professional Quality:** Pre-set 30-50 PSI allows for cut-in pressure adjustments.
- ◆ **New Nozzle Clean-out:** Easy plug removal and access for ease of service.
- ◆ **New Drain Plug:** Bottom-mounted for easy draining and winterization.

SPECIFICATIONS

- ◆ **Body and Seal Plate:** Fiberglass-reinforced thermoplastic.
- ◆ **Impeller:** Engineered composite.
- ◆ **Base:** 10-gauge steel.
- ◆ **Nozzle, Venturi, Diffuser:** Engineered composite.

ORDERING INFORMATION

CATALOG NUMBER	HP	DESCRIPTION	PIPE TAPPING SIZES		MOTOR VOLTAGE	APPROX. WT. LBS. / KG.
			SUCT.	DISCH.		
MPNC	1/2	Base Mounted Pump	1-1/4"	1"	115/230	21 / 9.5
MPND	3/4	Base Mounted Pump	1-1/4"	1"	115/230	24 / 11
MPNE	1	Base Mounted Pump	1-1/4"	1"	115/230	26 / 12

MYERS SHALLOW WELL JET PUMPS

OUTLINE DIMENSIONS

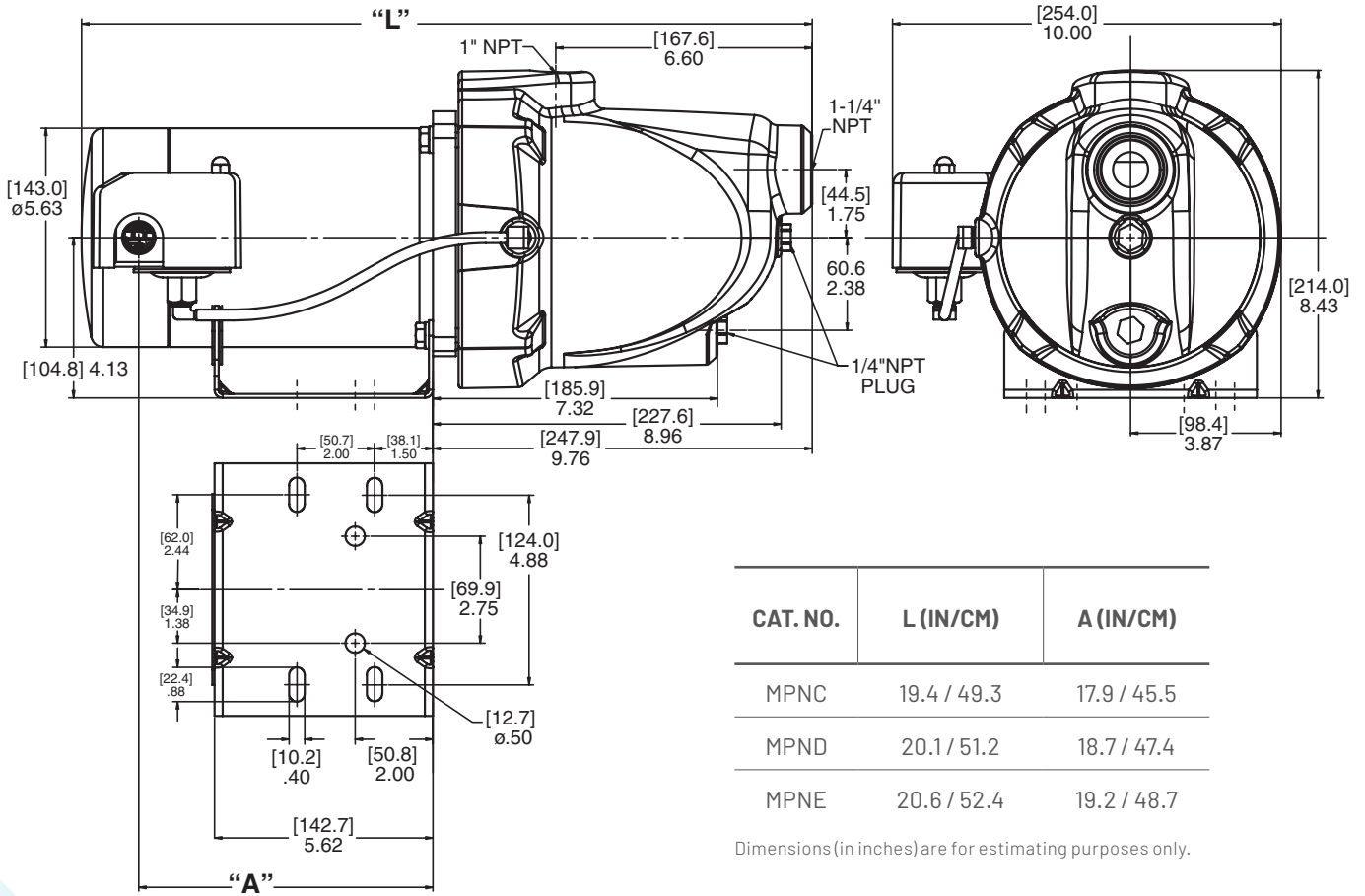

CAT. NO.	L (IN/CM)	A (IN/CM)
MPNC	19.4 / 49.3	17.9 / 45.5
MPND	20.1 / 51.2	18.7 / 47.4
MPNE	20.6 / 52.4	19.2 / 48.7

Dimensions (in inches) are for estimating purposes only.

PUMP PERFORMANCE

CATALOG NUMBER	HP	TOTAL SUCTION LIFT FT / M	DISCHARGE PRESSURE PSI / BAR			SHUT-OFF PSI / BAR
			30 / 2.1	40 / 2.8	50 / 3.5	
MPNC	1/2	5 / 1.5	8.5 / 32.2	7.4 / 28.0	5.2 / 19.7	77 / 5.30
		10 / 3.0	7.1 / 26.9	6.4 / 24.2	5.1 / 19.3	
		15 / 4.6	6.5 / 24.6	6.1 / 23.1	4.5 / 17.0	
		20 / 6.1	5.4 / 20.4	5.1 / 19.3	4.1 / 15.5	
		25 / 7.6	4.1 / 15.5	4.0 / 15.1	3.4 / 12.9	
MPND	3/4	5 / 1.5	12.1 / 45.8	10.7 / 40.5	8.5 / 32.2	78 / 5.37
		10 / 3.0	10.7 / 40.5	10.2 / 38.6	8.4 / 31.8	
		15 / 4.6	9.0 / 34.1	8.5 / 32.2	8.1 / 30.7	
		20 / 6.1	7.6 / 28.8	7.3 / 27.6	7.1 / 26.9	
		25 / 7.6	5.3 / 20.1	5.7 / 21.6	5.1 / 19.3	
MPNE	1	5 / 1.5	18 / 68.1	16.8 / 63.6	13.5 / 51.1	67 / 4.62
		10 / 3.0	17.1 / 64.7	16.1 / 60.9	13.4 / 50.7	
		15 / 4.6	14.9 / 56.4	14.4 / 54.5	13 / 49.2	
		20 / 6.1	12.6 / 47.7	12.2 / 46.2	12 / 45.4	
		25 / 7.6	8.8 / 33.3	8.5 / 32.2	8.1 / 30.7	

Pumps will operate at all depths shown, with pressure switch set at 30-50 PSI. Tested and rated in accordance with Water Systems Council Standards.

NOTE: Pumps installed with a Pro-Source® tank require a 100 PSI relief valve. Pumps installed with a conventional tank require a 75 PSI relief valve. Relief valve must be capable of relieving entire flow of pump at relief pressure.

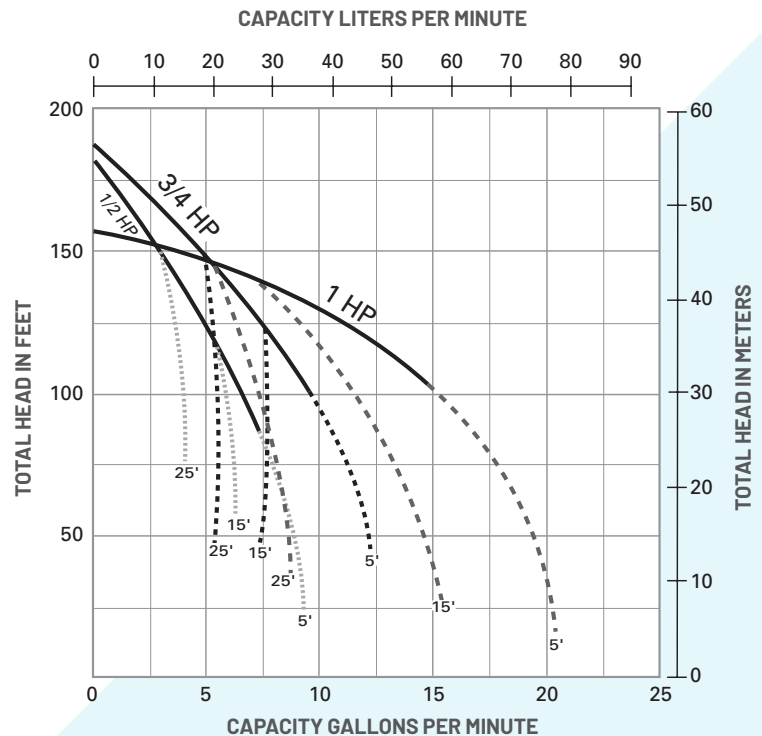



293 Wright St
Delavan, WI 53115
Ph: 888.987.8677
Fx: 800.426.9446

490 Pinebush Road, Unit 4,
Cambridge, Ontario N1T 0A5, Canada
Ph: 800.363.7867
Fx: 888.606.5484

pentair.com

All indicated Pentair trademarks and logos are property of Pentair. Third party registered and unregistered trademarks and logos are the property of their respective owners. Because we are continuously improving our products and services, Pentair reserves the right to change specifications without prior notice. Pentair is an equal opportunity employer.

©2022 Pentair. All Rights Reserved.

M9123WS (12-15-22)