

COMMERCIAL SEWAGE AND EFFLUENT PUMPS

WHR5H-WHR20H SERIES

The Myers WHR5H-WHR20H Series vortex pumps are designed for use in light commercial sewage and effluent applications.

Recessed impeller is standard allowing the pump to handle stringy waste without plugging the impeller. The series passes 2 inch solids.

FEATURES

Tough Against Corrosion: All cast iron construction resists the most extreme corrosive environments.

Runs Cooler: Oil-filled motor for bearing lubrication and maximum heat dissipation.

Flow to Meet Demand: Higher head performance for demanding sewage and effluent applications.

Powerful Starts: High-torque, permanent split capacitor (PSC) motor on single phase motors.

Thermal Protection: Single phase motors have heat sensor overload protection with automatic reset when motor cools to a safe operating temperature.

SPECIFICATIONS

- ◆ **Shut-Off Head:** Up to 71' (18.4 m)
- ◆ **Solids Handling:** 2" (50.8 mm)
- ◆ **Liquids Handling:** Raw sewage and sewage effluent
- ◆ **Intermittent Liquid Temp.:** Up to 140°F (60°C)
- ◆ **Motor/Electrical Data:** 1/2 HP 115V, 1/2, 1, 1-1/2 and 2 HP 208/230V 1Ø, 60 Hz 3400 RPM PSC; 1/2, 1, 1-1/2, and 2 HP 208-230/460V, 575V 3Ø, 60Hz 3450 RPM
- ◆ **Acceptable pH Range:** 6-9
- ◆ **Discharge NPT:** 2", Optional 3"
- ◆ **Housing:** Cast iron
- ◆ **Power Cord:** 1/2 HP 115 V = 20' (6.1 m), 14/3, SJOW/SJOW-A, 1Ø. All other 1Ø = 16/3 cords. All 3Ø = 20' (6.1 m), 16/4, SJOW/SJOW-A
- ◆ **Impeller:** Ductile iron, recessed
- ◆ **Volute Case:** Cast iron
- ◆ **Shaft Seal:** Type 21, carbon and ceramic
- ◆ **Minimum Sump Diameter:** Simplex: 24" (610 mm); Duplex: 30" (762 mm)



Tested & Certified to UL778
and CSA 108.

3 Year Warranty

WHR5H-WHR20H SERIES COMMERCIAL SEWAGE AND EFFLUENT PUMPS

ORDERING INFORMATION

MODEL NUMBER	HP	VOLTS	PHASE	DISCHARGE NPT	SWITCH TYPE	CORD LENGTH	WT. LBS
WHR5H-11	1/2 (0.37 kw)	115	1	2" NPT	Manual	20' (6.1 mm)	75 (34 kg)
WHR5H-01		208	1				
WHR5H-21		230	1				
WHR5H-03		208	3				
WHR5H-23		230	3				
WHR5H-43		460	3				
WHR5H-53		575	3				
WHR10H-01	1 (0.75 kw)	208	1	2" NPT	Manual	20' (6.1 mm)	79 (35.8 kg)
WHR10H-21		230	1				
WHR10H-03		208	3				
WHR10H-23		230	3				
WHR10H-43		460	3				
WHR10H-53		575	3				
WHR15H-01	1-1/2 (1.1 kw)	208	1	2" NPT	Manual	20' (6.1 mm)	85 (38.6 kg)
WHR15H-21		230	1				
WHR15H-03		208	3				
WHR15H-23		230	3				
WHR15H-43		460	3				
WHR15H-53	575	3					
WHR20H-21	2 (1.5 kw)	230	1	2" NPT	Manual	20' (6.1 mm)	95 (43.1 kg)
WHR20H-03		208	3				
WHR20H-23		230	3				
WHR20H-43		460	3				

DIMENSIONS

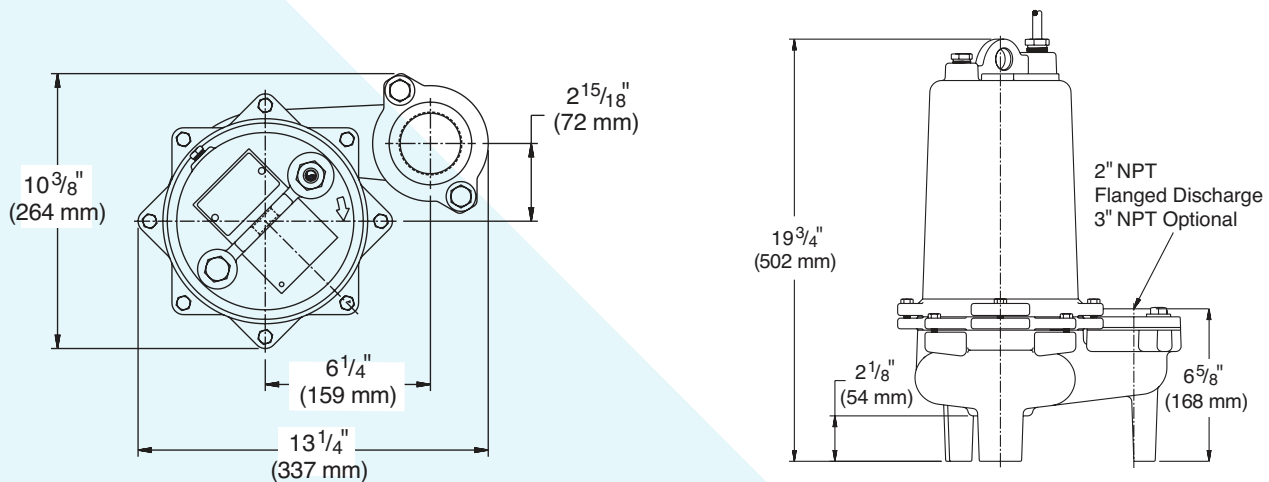

WHR5H-WHR20H SERIES COMMERCIAL SEWAGE AND EFFLUENT PUMPS

PERFORMANCE

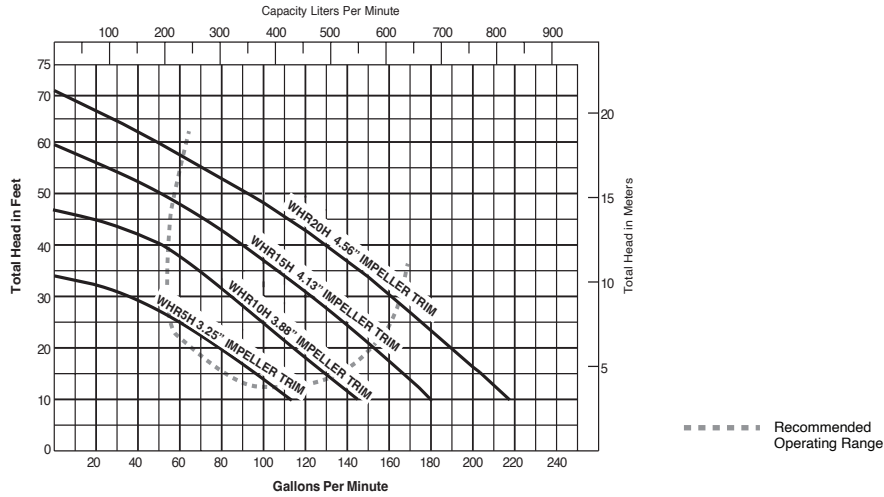

MOTOR ELECTRICAL DATA

MODEL NUMBER	HP	VOLTS	PHASE	HERTZ	START MAX AMPS	RUN AMPS	RUN KW	START KVA	NEC code KVA	LETTER
WHR5H-11	1/2	115	1	60	30.4	13.8	1.9	3.5	1.6	H
WHR5H-01	1/2	208	1	60	16.2	7.6	1.7	3.4	1.6	H
WHR5H-21	1/2	230	1	60	16.2	6.9	1.7	3.7	1.6	H
WHR5H-03	1/2	208	3	60	20.2	5.2	1.4	7.3	1.9	R
WHR5H-23	1/2	230	3	60	20.2	4.7	1.4	8.0	1.9	S
WHR5H-43	1/2	460	3	60	10.1	2.3	1.4	8.0	1.9	S
WHR5H-53	1/2	575	3	60	8.1	1.9	1.4	8.0	1.9	S
WHR10H-01	1	208	1	60	28.0	14.8	3.0	5.8	2.8	B
WHR10H-21	1	230	1	60	23.0	12.8	3.0	5.3	2.8	B
WHR10H-03	1	208	3	60	30.0	7.7	2.5	10.8	3.0	J
WHR10H-23	1	230	3	60	30.0	7.0	2.5	10.8	3.0	K
WHR10H-43	1	460	3	60	15.0	3.5	2.5	11.9	3.0	K
WHR10H-53	1	575	3	60	12.0	2.8	2.5	11.9	3.0	K
WHR15H-01	1-1/2	208	1	60	39.9	15.3	3.3	8.3	3.2	D
WHR15H-21	1-1/2	230	1	60	33.4	13.1	3.3	7.7	3.0	C
WHR15H-03	1-1/2	208	3	60	30.0	8.5	2.8	10.8	3.4	F
WHR15H-23	1-1/2	230	3	60	30.0	7.7	2.8	11.9	3.1	G
WHR15H-43	1-1/2	460	3	60	15.0	3.9	2.8	11.9	3.1	G
WHR15H-53	1-1/2	575	3	60	12.0	3.1	2.8	11.9	3.1	G
WHR20H-21	2	230	1	60	63.0	18.0	3.8	14.5	3.7	E
WHR20H-03	2	208	3	60	53.0	10.4	3.3	19.1	3.6	G
WHR20H-23	2	230	3	60	46.0	9.0	3.3	18.3	3.6	G
WHR20H-43	2	460	3	60	23.0	4.5	3.3	18.3	3.6	G



293 Wright Street
Delavan, WI 53115
Ph: 888.987.8677
Fx: 800.426.9446

490 Pinebush Road, Unit 4
Cambridge, Ontario, Canada N1T 0A5
Ph: 800.363.7867
Fx: 888.606.5484

pentair.com

All indicated Pentair trademarks and logos are property of Pentair. Third party registered and unregistered trademarks and logos are the property of their respective owners. Because we are continuously improving our products and services, Pentair reserves the right to change specifications without prior notice. Pentair is an equal opportunity employer.

©2023 Pentair. All Rights Reserved.

M9034 (08-01-2023)