

SEWAGE PUMPS

MW SERIES

The Myers MW Series Sewage Pumps are designed for light commercial and residential raw sewage applications. The enclosed two-vane impeller provides high-efficiency pumping and will easily handle stringy, trashy 2" solids without clogging. The heavy-duty cast iron construction ensures years of service in demanding applications. Available in single- and double seal models; cast iron and optional bronze impeller models.

APPLICATIONS

Sewage, high-capacity sump, and effluent.



FEATURES

- ◆ **Cast Iron Tough:** All cast-iron housing and volute case stand tough against extremely corrosive environments.
- ◆ **No Jamming:** Enclosed impeller design eliminates jamming between impeller and volute – cast iron or bronze (optional).
- ◆ **Powerful Starts:** High-torque, permanent split capacitor (PSC) motor; no starting switches or relays to wear out.
- ◆ **Motor Protection:** Rugged, oil-filled motor for bearing lubrication and maximum heat dissipation.
- ◆ **Guards Against Leaks:** Optional leak probe senses water leakage past seal (dual seal motors only).
- ◆ **Prevents Overheating:** Heat sensor overload protection with automatic reset when motor cools to a safe operating temperature (single phase only).
- ◆ **Easy Service:** Remove only four screws for motor access; volute seal ring is replaceable.

SPECIFICATIONS

- ◆ **Capacities:** Up to 165 GPM (624 LPM)
- ◆ **Shut-Off Head:** Up to 70' (21.3 m)
- ◆ **Solids Handling:** 2" (50.8 mm)
- ◆ **Liquids Handling:** Domestic sewage and drain water
- ◆ **Intermittent Liquid Temp.:** Up to 140°F (60°C)
- ◆ **Motor/Electrical Data:** 1/2 to 2 HP, 208/230V, 1Ø; 208/230/460/575V, 3Ø, oil-filled, permanent split, capacitor type, 1Ø, 3450 RPM, 60Hz
- ◆ **Acceptable pH Range:** 5-9
- ◆ **Discharge NPT:** 2"
- ◆ **Housing:** Cast iron
- ◆ **Power Cord:** 20'
- ◆ **Impeller:** Ductile iron; bronze (optional) available on double seal models – consult factory
- ◆ **Volute Case:** Class 30 cast iron
- ◆ **Shaft Seal:** Type 21, carbon and ceramic
- ◆ **Minimum Sump Diameter:** Simplex: 24" (61 cm); Duplex: 36" (91.4 cm)

SEWAGE PUMPS MW SERIES

DIMENSIONAL DATA

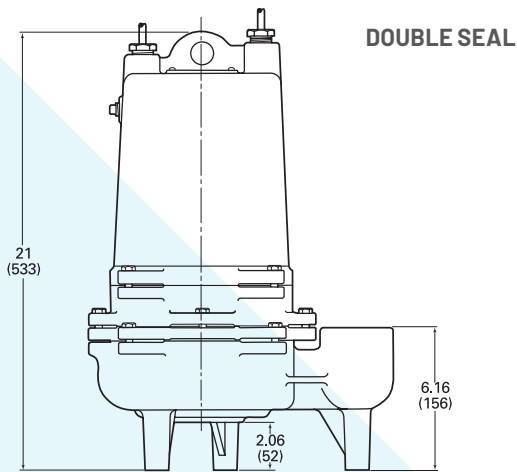
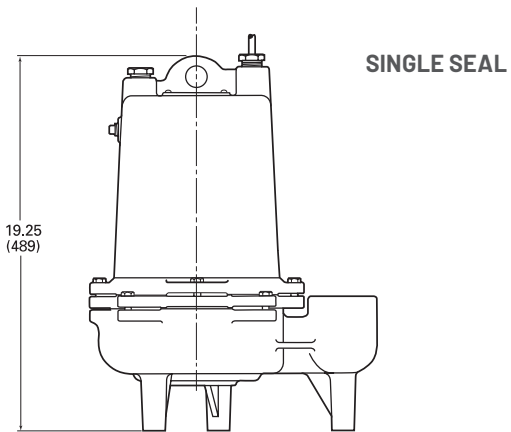
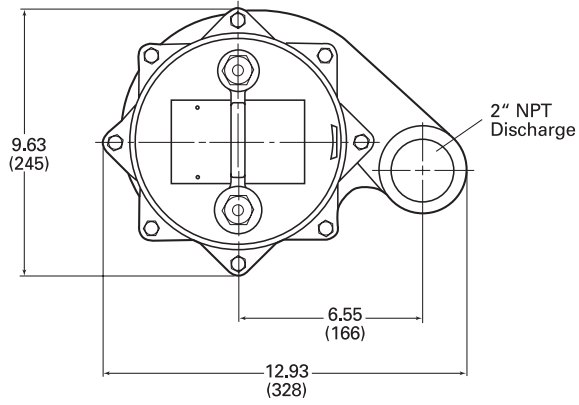

PUMP PERFORMANCE

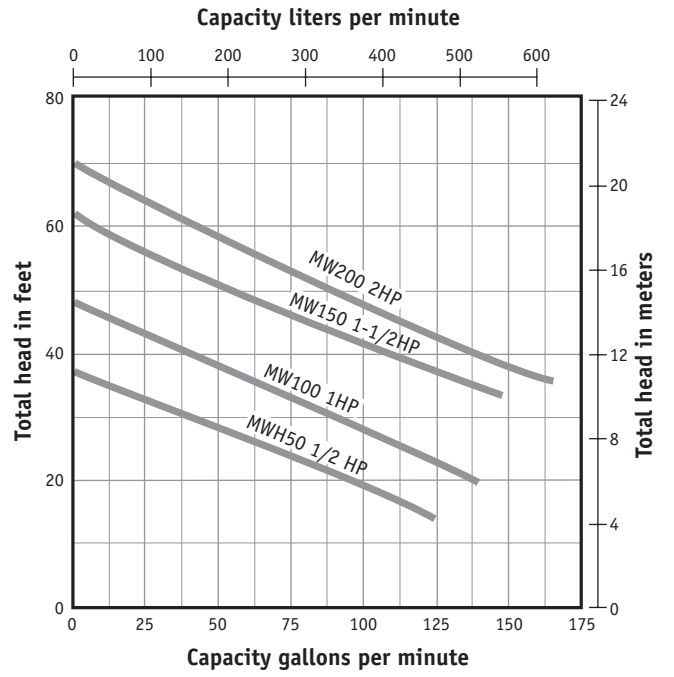

SEWAGE PUMPS MW SERIES

ORDERING INFORMATION

CATALOG NUMBER	HP	VOLTS	PHASE	DISCHARGE NPT	SWITCH TYPE	APPROX. CORD LENGTH	WT. LBS
SINGLE SEAL							
MWH50-01P	1/2	200	1	2"	Automatic*	20'	84
MWH50-21	1/2	230	1	2"	Manual	20'	84
MWH50-21P	1/2	230	1	2"	Automatic*	20'	84
MWH50-03	1/2	200	3	2"	Manual	20'	84
MWH50-43	1/2	460	3	2"	Manual	20'	84
MWH50-53	1/2	575	3	2"	Manual	20'	84
MW100-01	1	200	1	2"	Manual	20'	86
MW100-21	1	230	1	2"	Manual	20'	86
MW100-03	1	200	3	2"	Manual	20'	86
MW100-23	1	230	3	2"	Manual	20'	86
MW100-43	1	460	3	2"	Manual	20'	86
MW100-53	1	575	3	2"	Manual	20'	86
MW150-21	1-1/2	230	1	2"	Manual	20'	87
MW150-03	1-1/2	200	3	2"	Manual	20'	87
MW150-23	1-1/2	230	3	2"	Manual	20'	87
MW150-43	1-1/2	460	3	2"	Manual	20'	87
MW150-53	1-1/2	575	3	2"	Manual	20'	87
MW200-01	2	200	1	2"	Manual	20'	88
MW200-21	2	230	1	2"	Manual	20'	88
MW200-03	2	200	3	2"	Manual	20'	88
MW200-23	2	230	3	2"	Manual	20'	88
MW200-43	2	460	3	2"	Manual	20'	88
MW200-53	2	575	3	2"	Manual	20'	88

*Piggyback

Note: Consult factory for Double Seal models



293 Wright St
Delavan, WI 53115
Ph: 888.987.8677
Fx: 800.426.9446

490 Pinebush Rd, Unit 4
Cambridge, Ontario N1T 0A5, Canada
Ph: 800.363.7867
Fx: 888.606.5484

pentair.com

All indicated Pentair trademarks and logos are property of Pentair. Third party registered and unregistered trademarks and logos are the property of their respective owners. Because we are continuously improving our products and services, Pentair reserves the right to change specifications without prior notice. Pentair is an equal opportunity employer.

©2023 Pentair. All Rights Reserved.

M9032SSE (08-01-23)