



# 2 HP SUBMERSIBLE GRINDER PUMPS

## MODELS WG20 AND WGX20

Standard (WG20) and Hazardous Location (WGX20) Construction



# PENTAIR MYERS MODELS WG20 AND WGX20 SUBMERSIBLE GRINDER PUMPS

## DESIGNED FOR RESIDENTIAL, LIGHT COMMERCIAL AND INDUSTRIAL APPLICATIONS

The Myers WGX20 Series are rugged 2 horsepower submersible centrifugal grinder pumps designed for residential, light commercial or industrial applications. It is especially suited for use in pressure sewer applications or in systems with long discharge runs or high static heads.

The WG20 Series features a recessed impeller design to efficiently grind typical domestic sewage solids into a fine slurry. These pumps are available in standard construction and construction for use in Class 1, Group D hazardous locations.

The WG20 Series can be installed in a variety of packaged systems. Factory-assembled simplex or duplex packages with guide rail systems are available. Individual rail components are also available for installation in on-site concrete systems. Myers offers a complete line of submersible sump, sewage, effluent, grinder, solids handling wastewater pumps, controls, basins, and accessories. For additional information, please contact your Myers representative or the Myers Ashland, Ohio sales office at 855-274-8948.



PRODUCT CAPABILITIES		
Capacities To	40 gpm	151 lpm
Heads To	98.4 ft.	30 m
Liquids Handling	Domestic Raw Sewage	
Intermittent Liquid Temp.	Up to 140°F	Up to 60°C
Winding Insulation Temp. (Class F)	311°F	155°C
Motor Electrical Data (Single phase motors are capacitor start and capacitor run type. Myers control panels or capacitor kits are required for proper operation and warranty.)	2 HP, 3450 RPM 1 ph – capacitor start/run. 208 or 230 volts; 60 Hz 3 ph – induction run 208, 230, 460, 575 volts, 60 Hz	
Third-Party Approvals	WG – CSA WGX – CSA, FM	
Acceptable pH Range	6-9	
Specific Gravity	.9-1.1	
Viscosity	28-35 SSU	
Discharge, NPT	1-1/4 in.	31.75 mm
Min. Sump Diameter		
Simplex	24 in.	61.0 cm
Duplex	36 in.	91.4 cm

CONSTRUCTION MATERIALS	
Motor Housing, Seal Housing, Cord Cap and Volute Case	Cast Iron, Class 30, ASTM A48
Impeller	Recessed, 316 SST/CF8M
Power Cord	S00W
Control Cord	S00W
Mechanical Seals: Standard	Double Tandem Carbon and Ceramic Lower Tungsten Carbide
Optional	
Pump, Motor Shaft	416 SST
Fasteners	300 Series SST
Shredding Ring, Grinding Impeller	440 SST, 58-60 Rockwell

**NOTE:** Consult factory for applications outside these recommendations.

# PUMP FEATURES AND APPLICATIONS

## A. STATOR—2 HP

2 HP, 3500 RPM, 1 and 3 phase. Press fit for perfect alignment and best heat transfer. Oil-filled motor conducts heat and lubricates bearings.

## B. CABLE ENTRY SYSTEM

Provides double seal protection. Cable jacket sealed by compression fitting. Individual wires sealed by epoxy potting.

## C. HEAT SENSOR

Protects motor from burnout due to excessive heat from any overload condition. Automatically resets when motor has cooled.

## D. BALL BEARINGS

Upper and lower ball bearings support shaft and rotor and take axial and radial loads.

## E. HEAVY 416 SST SHAFT

Corrosion resistant. Reduces shaft deflection due to grinding loads.

## F. SHAFT SEALS

Double tandem mechanical shaft seals protect motor. Oil-filled seal chamber provides continuous lubrication.

## G. SEAL LEAK PROBE

Detects water in seal housing, activates warning light in control panel.

## H. VOLUTE CASE

Cast iron 1-1/4" NPT vertical discharge.

## I. IMPELLER

SST recessed impeller handles ground slurry without clogging or binding. Provides unobstructed flow passage. Reduces radial loads. Pump-out vanes help keep trash from seal, reduces pressure at seal faces.

## J. SLEEVE BEARING

Takes radial load; provides flame path.

## K. GRINDER ASSEMBLY

Grinder impeller and shredding ring are replaceable without dismantling pump. Constructed of 440 SST hardened to 56-60 Rockwell.

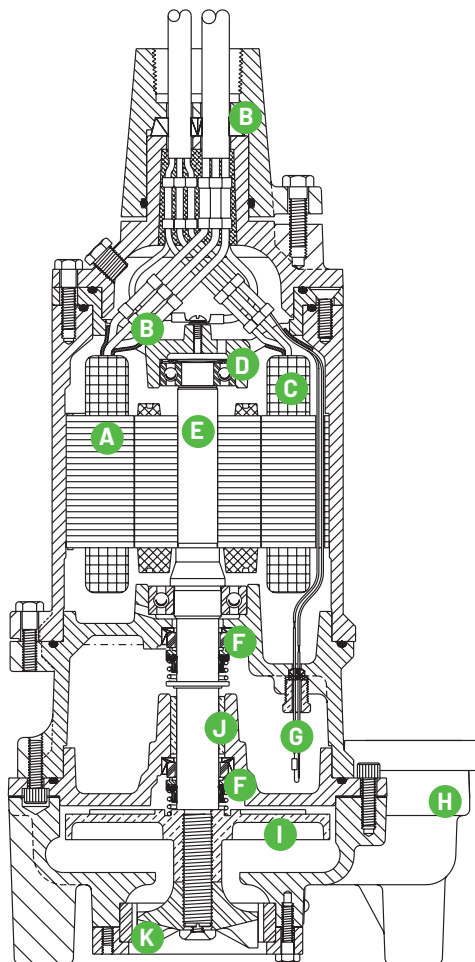

## IDEAL FOR USE IN PRESSURE SEWER SYSTEMS

- ◆ Recessed impeller provides steep non-overloading operating curve.

## DURABLE MOTOR BUILT FOR RELIABLE SERVICE

- ◆ Oil-filled motor for maximum heat dissipation and constant bearing lubrication.
- ◆ Recessed impeller reduces radial bearing loads, increases bearing life.
- ◆ High torque capacitor start/run single phase or three phase motors for assured starting under heavy load.
- ◆ Seal leak probes and on-winding heat sensors warn of seal leak condition and stop motor if motor overheats. Helps prevent costly motor damage.

## THE WGX20 SERIES IS DESIGNED FOR EASY MAINTENANCE

- ◆ Shredding ring and grinder impeller are replaceable without dismantling pump or motor.

# PERFORMANCE DATA AND DIMENSIONS

## RPM: 3500 DISCHARGE: 1-1/4"

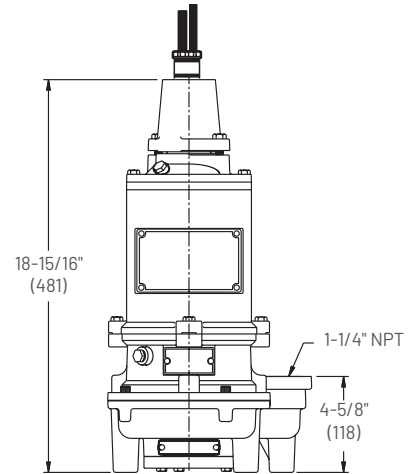
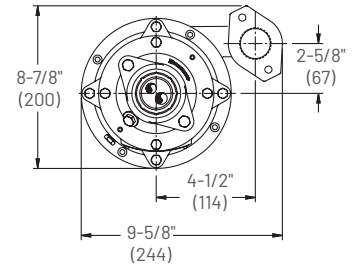
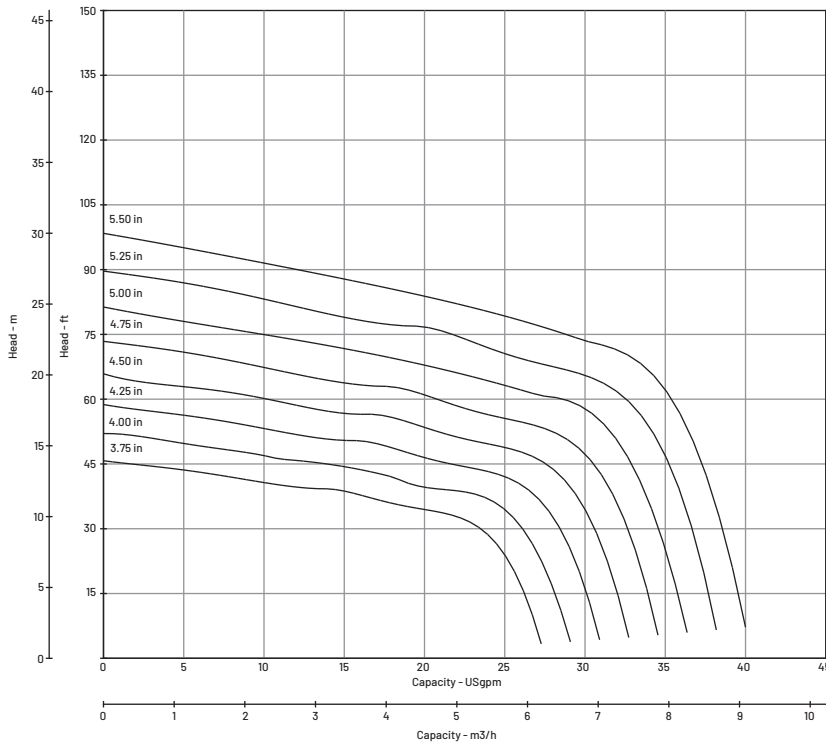

AVAILABLE MODELS		MOTOR ELECTRICAL DATA										
Standard	Hazardous Location	HP	Voltage	Phase	Hertz	RPM	Start Amps	FLA	Full Load KW	Start KVA	NEC Code Letter	Service Factor
WG20-01	WGX20-01	2	208	1	60	3500	52.9	15	2.6	11.0	F	1.25
WG20-03	WGX20-03	2	208	3	60	3500	34.7	9.5	2.5	12.5	F	1.25
WG20-21	WGX20-21	2	230	1	60	3500	61.5	13.5	3.0	14.1	F	1.25*
WG20-23	WGX20-23	2	230	3	60	3500	35	8.4	2.9	13.9	F	1.25
WG20-43	WGX20-43	2	460	3	60	3500	17.7	4.2	2.9	14.1	F	1.25
WG20-53	WGX20-53	2	575	3	60	3500	13.4	3.4	2.6	13.4	F	1.25

\*1.15 SF on WG20-21 only



1101 Myers Parkway | Ashland, OH 44805 | PH: 855.274.8948 | [pentair.com/myers](http://pentair.com/myers)

All FM Approvals' certification marks are the sole property of FM Approvals LLC.

CSA is a registered trademark of CSA Group. All Rights Reserved.

All indicated Pentair trademarks and logos are property of Pentair. Third party registered and unregistered trademarks and logos are the property of their respective owners.

