



OWNER'S MANUAL

Sewage Ejector Pump/Basin Package

HYDROMATIC®

NOTE! To the installer: Please make sure you provide this manual to the owner of the pumping equipment or to the responsible party who maintains the system.

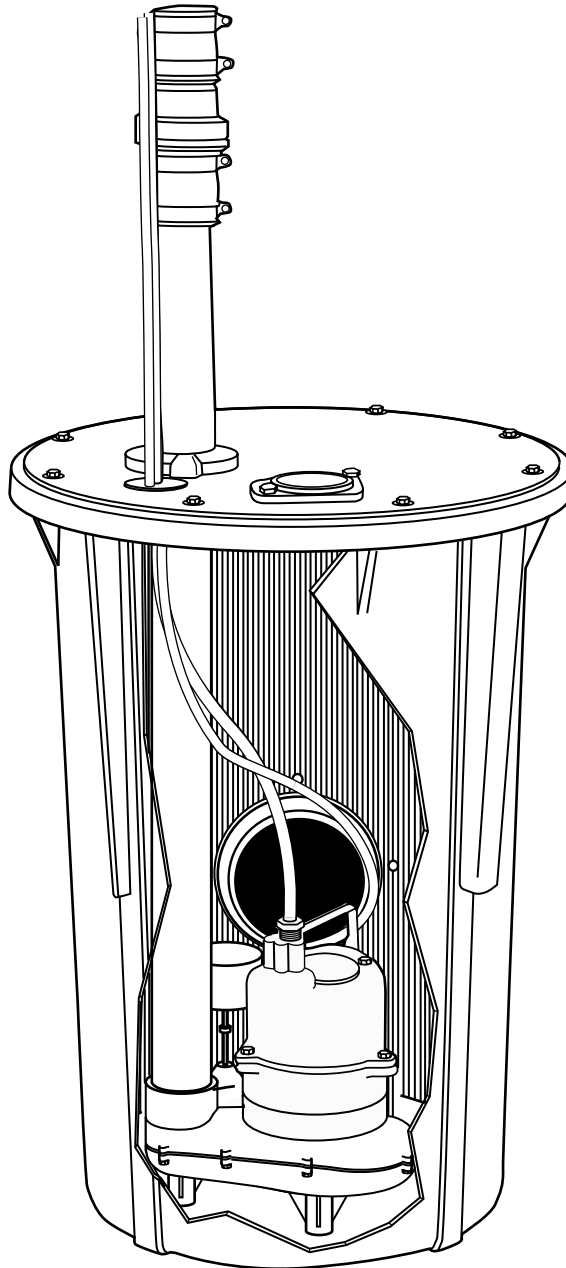

293 WRIGHT STREET, DELAVAN, WI 53115 WWW.HYDROMATIC.COM
PH: 888-782-7483
490 PINEBUSH ROAD, UNIT 4 CAMBRIDGE, ONTARIO N1T 0A5
PH: 519-896-2163

© 2014 Pentair Ltd. All Rights Reserved.

W-03-461 (03/12/14)

Your 218 Package is designed to operate automatically or manually and for simple and quick installation. Its preset fluid level control allows for efficient operation when installed in a standard 18" x 30" sewage basin.

Before installing your pump, check carefully for shipping damage. Any claim for shipping damage must be made with your supplier at the point of purchase. **The manufacturer can not make shipping damage adjustments.**

Installation

This is a sewage handling pump and must be vented in accordance with local plumbing codes. This pump is not to be installed in locations classified as hazardous in accordance with National Electric Code, ANSI/NFPA 70.

The motor in your new submersible sewage pump is oil-filled for efficient operation. **DO NOT loosen the three motor housing screws.**

Place sewage pump on the bottom of the basin and position it to allow float to move freely in center of basin (see Figure 1). Check that nothing interferes with the float switch.

Slip cover over discharge pipe and power cord. Bolt cover securely to basin (be sure to use a cover gasket). Install discharge compression fitting and cord seal grommet.

Check Valve

A properly designed full-flow check valve **MUST** be used on every installation. A series CUCV-2C is provided. It eliminates back-flow, reduces vibration and acts as a pipe union for easy servicing. Install on discharge pipe (make certain that arrow on valve body points in flow direction). Connect outlet of check valve to the plumbing line leading to the sanitary sewer system.

Electrical Information

WARNING, risk of electric shock.

This pump is supplied with a grounding conductor and grounding-type attachment plug. To reduce the risk of electric shock, be certain that it is connected only to a properly grounded, grounding-type receptacle. Read instructions before installing pump. This pump has not been investigated for use in swimming pool use.

Never touch the sewage pump, switch or discharge pipe when the pump is connected to electrical power.

Check the electrical circuit to make sure it meets the voltage and amperage requirement listed on the motor nameplate.

Your electrical service outlet should meet the National Electric Code and/or local codes. Your pump should have a separate branch circuit, properly fused and grounded. The outlet should be 4' above the floor and close enough to your pump that the original cord can reach it. **Never use an extension cord.**

Plug the switch power cord into a properly grounded outlet. Plug the pump power cord into the back of the switch cord plug. Tape the power cords to the discharge pipe every 12 inches to make sure any movement will not damage the insulation. Do a neat job!

To test the system, add water to the sewage basin until the float switch operates normally.

Your pump has thermal overload protection. If the impeller becomes locked because of a foreign object, the motor will overheat and the thermal overload switch will cut off the electricity. Unplug pump and remove the foreign object immediately. See that the impeller turns freely.

Caution — Always disconnect your pump and switch from the electrical power source before doing any maintenance.

Switch Adjustment and Replacement Instructions

Caution — Always disconnect the pump and switch from the electrical power source before doing any maintenance! This pump is equipped with a float switch and does not control both sides of the electrical circuit. To reduce the risk of electric shock it is essential that it be wired in series with the hot side of the electrical circuit. Make sure your outlets are wired according to your local electrical code.

1. Inspect the pump to be certain that there are no rocks, lint, etc. clogging the openings where water enters the pump housing. Remove any debris. Check to see that the impeller turns freely.
2. Plug the pump power cord into a properly grounded, 3-hole outlet. If the pump works, (impeller turns and air is blowing out of discharge opening), proceed to Step 3. **If the pump does not work, it must be replaced.**
3. If the pumps works, (1) unplug pump and (2) re-plug into back of switch plug and (3) plug the assembly into the electrical outlet. Raise switch by hand to activate pump. If pump turns on, pump and switch are OK - no need to replace. If pump does not turn on, the switch is defective and must be replaced. Proceed to Step 4. Then, with a new switch, repeat Step 3. If pump turns on, the problem is solved.
4. To replace switch, remove bolt that holds bracket. Mount switch by inserting new bolt into handle hole.

California Proposition 65

Warning

▲ WARNING This product and related accessories contain chemicals known to the State of California to cause cancer, birth defects or other reproductive harm.

Typical Sewage System Installation

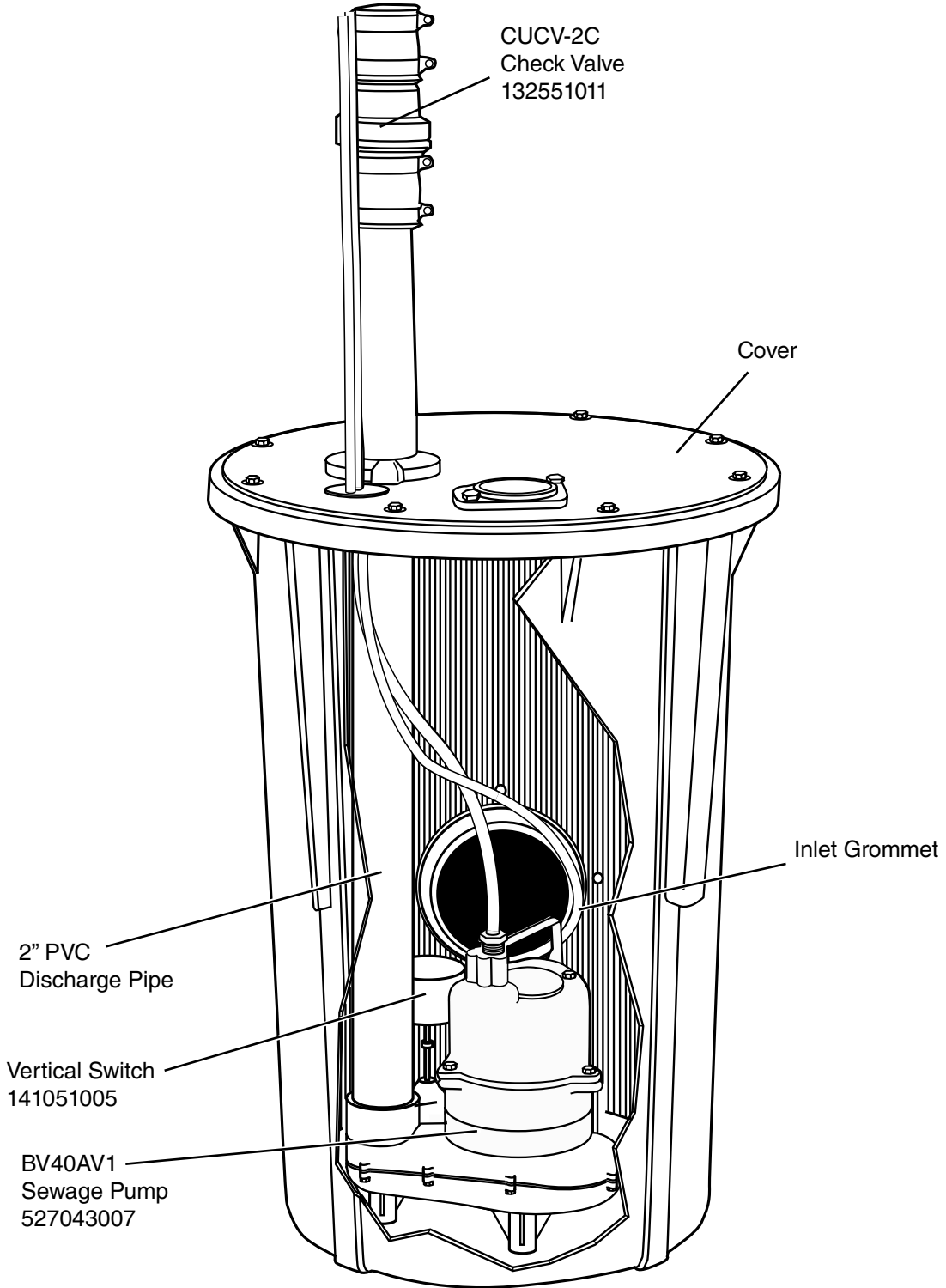

Limited Warranty

HYDROMATIC warrants to the original consumer purchaser ("Purchaser" or "You") of HYDROMATIC Sump Pumps, Effluent Pumps, Sewage Pumps (other than 2-1/2"), and Package Systems, that they will be free from defects in material and workmanship for the Warranty Period of 36 months from date of manufacture.

Our warranty will not apply to any product that, in our sole judgement, has been subject to negligence, misapplication, improper installation, or improper maintenance. Without limiting the foregoing, operating a three phase motor with single phase power through a phase converter will void the warranty. Note also that three phase motors must be protected by three-leg, ambient compensated, extra-quick trip overload relays of the recommended size or the warranty is void.

Your only remedy, and HYDROMATIC's only duty, is that HYDROMATIC repair or replace defective products (at HYDROMATIC's choice). You must pay all labor and shipping charges associated with this warranty and must request warranty service through the installing dealer as soon as a problem is discovered. No request for service will be accepted if received after the Warranty Period has expired. This warranty is not transferable.

EXCEPTIONS: Hydromatic Special Application Pumps, Battery Back-Up Sump Pumps, Filtered Effluent Pumps, Grinder Pumps, and 2-1/2" Sewage Pumps are warranted for a period of 12 months from date of purchase or 18 months from date of manufacture, whichever comes first.

HYDROMATIC SHALL NOT BE LIABLE FOR ANY CONSEQUENTIAL, INCIDENTAL, OR CONTINGENT DAMAGES WHATSOEVER.

THE FOREGOING LIMITED WARRANTIES ARE EXCLUSIVE AND IN LIEU OF ALL OTHER EXPRESS AND IMPLIED WARRANTIES, INCLUDING BUT NOT LIMITED TO IMPLIED WARRANTIES OF MERCHANTABILITY AND FITNESS FOR A PARTICULAR PURPOSE. THE FOREGOING LIMITED WARRANTIES SHALL NOT EXTEND BEYOND THE DURATION PROVIDED HEREIN.

Some states do not allow the exclusion or limitation of incidental or consequential damages or limitations on the duration of an implied warranty, so the above limitations or exclusions may not apply to You. This warranty gives You specific legal rights and You may also have other rights which vary from state to state.

This Limited Warranty is effective June 1, 2011 and replaces all undated warranties and warranties dated before June 1, 2011.

HYDROMATIC

293 Wright Street, Delavan, WI 53115

Phone: 888-957-8677 • Fax: 800-426-9446 • Web Site: hydromatic.com