

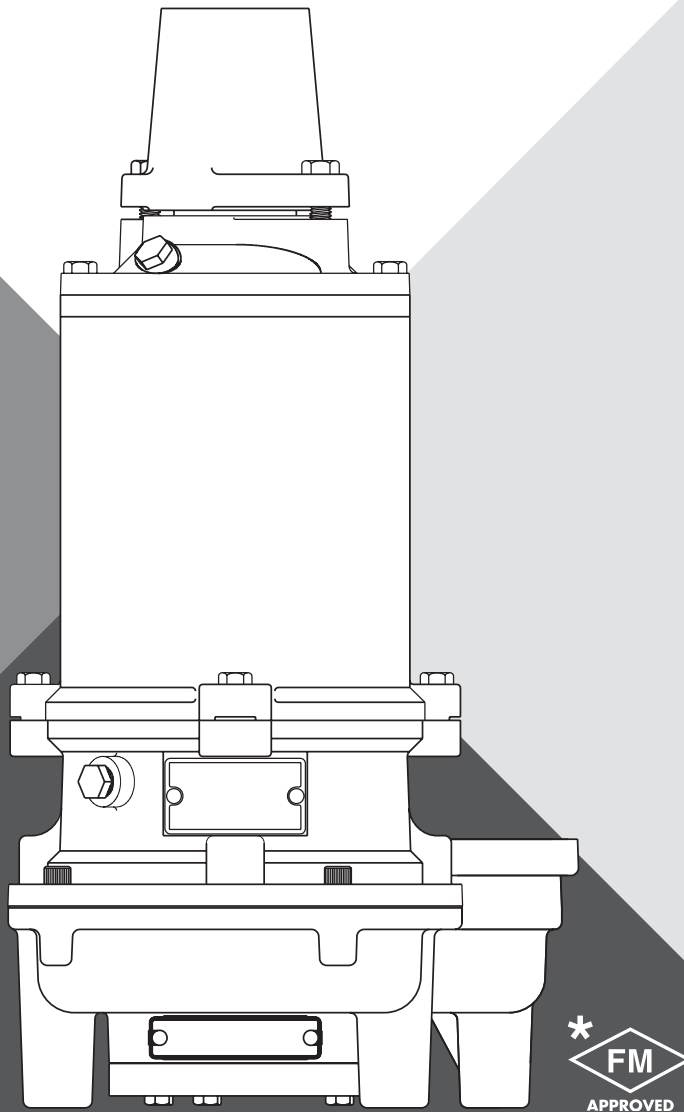

HYD12731 / 056255671 (07-15-24)

# 2 HP SUBMERSIBLE SEWAGE GRINDER PUMP HWG(X) MODELS



\*Used in Hazardous Locations Class I, Division 1, Groups C & D

## OWNER'S MANUAL

[pentair.com/hydromatic](https://www.pentair.com/hydromatic)

©2024 Pentair. All Rights Reserved.

# TABLE OF CONTENTS

---

SAFETY INFORMATION ..... 3

INSTALLATION & OPERATION ..... 4

HWG(X) PUMP PARTS LIST ..... 6

TROUBLESHOOTING..... 7

MOTOR WIRING DIAGRAMS ..... 9

DIMENSIONS ..... 10

WARRANTY ..... 11

# SAFETY INFORMATION

## SAFETY SYMBOLS

 This is the safety alert symbol. When you see this symbol on your pump or in this manual, look for one of the following signal words and be alert to the potential for personal injury:

 **DANGER** warns about hazards that will cause serious personal injury, death or major property damage if ignored.

 **WARNING** warns about hazards that can cause serious personal injury, death or major property damage if ignored.



 **CAUTION** warns about hazards that will or can cause minor personal injury or property damage if ignored.



The word **NOTICE**: indicates special instructions that are important but not related to hazards.

## CALIFORNIA PROPOSITION 65 WARNING

 **WARNING** This product and related accessories contain chemicals known to the State of California to cause cancer, birth defects or other reproductive harm.

## GENERAL SAFETY

- ◆  **CAUTION** Do not touch an operating motor. Modern motors can operate at high temperatures. To avoid burns when servicing pump, allow it to cool for 30 minutes after shutdown before handling.
- ◆ Follow all applicable local and state codes and regulations.
- ◆ Submersible pumps are not approved for and should not be used in swimming pools, recreational water installations, decorative fountains or any installation where human contact with the pump fluid is common. Pump is designed for municipal and commercial wastewater applications.
- ◆ Keep safety labels in good condition, replacing any missing or damaged labels.
- ◆ **DO NOT** run the pump dry. Dry running can overheat the pump, (causing burns to anyone handling it) and will void the warranty.
- ◆ The pump is permanently lubricated. No oiling or greasing is required in normal operation.
- ◆ Periodically inspect pump and system components.
- ◆ Wear safety glasses at all times when working on pumps.
- ◆ Keep work area clean, uncluttered and properly lighted. Store all unused tools and equipment.
- ◆ **DO NOT** use to pump flammable liquids.
- ◆  **DANGER RISK OF FIRE OR EXPLOSION.** Can cause severe personal injury, property damage or death. Do not smoke or use open flames in or around this system.

- ◆  **DANGER CUTTING RISK.** Risk of serious cutting or amputation exists. Use caution as liner plate is extremely sharp. Always keep fingers and hands away from cutting profiles. Disconnect all power sources prior to servicing pump. Pump may start without warning.
- ◆  **DANGER RISK OF ASPHYXIATION.** Installer(s) and/or service personnel must use proper Personal Protective Equipment and follow OSHA 29 CFR 1910.146 or OSHA 29 CFR 1926. Pump may be installed in a location classified as a confined space.
- ◆  **DANGER BIOHAZARD RISK.** Once wastewater source has been connected to system, Biohazard Risk exists. Installer(s) and/or service personnel must use proper personal Protective Equipment and follow handling procedures per OSHA 29 CFR 1910.1030 when handling equipment after wastewater source has been connected to system.
- ◆ **NOTICE:** FM rated models are only to be used in 60hz applications.

## ELECTRICAL SAFETY

 **DANGER HAZARDOUS VOLTAGE. CAN SHOCK, BURN, OR KILL.** When installing, operating, or servicing this pump, follow the safety instructions listed below.

- ◆  **DANGER ELECTROCUTION HAZARD:** Must be installed by a qualified professional. Disconnect all electrical power before attempting service.
- ◆ **DO NOT** modify the cord. When wiring to a system control, connect ground lead to the system ground.
- ◆ **DO NOT** splice the electrical power cord.
- ◆ **DO NOT** allow the power leads on the end of the electrical cords to be submerged.
- ◆ **DO NOT** handle or service the pump while it is connected to the power supply.

 **WARNING** A water test must be taken before installation of any water treatment equipment. The water quality can significantly influence the life of your system. You should test for corrosive elements, acidity, total solids and other relevant contaminants, including chlorine and treat your water appropriately to ensure satisfactory performance and prevent premature failure.

# INSTALLATION & OPERATION

---

Submersible grinder pumps are not approved for use in swimming pools, recreational water installations, decorative fountains or any installation where human contact with the pumped fluid is common. This specialized pump is designed to incorporate a grinding mechanism to remove wastewater particulate and pump the resulting slurry from a residential structure to a collection system.

ON THREE PHASE PUMPS ONLY "MOTOR PROTECTION" MUST BE PROVIDED BY THE INSTALLER. ALL THREE PHASE PUMPS MUST BE INSTALLED WITH MAGNETIC STARTERS HAVING THREE LEG OVERLOAD PROTECTION IN ACCORDANCE WITH THE NATIONAL ELECTRIC CODE. FOR INSTALLATIONS WITH MORE THAN ONE PUMP, EACH PUMP MOTOR MUST HAVE SEPARATE OVERLOAD PROTECTION.

PUMPS WITH SEAL LEAK DETECTORS MUST BE CONNECTED TO THE PROPER CONTROL CIRCUITRY.

Examine all lifting devices, rope or chain for damage before and after each lift.

**DO NOT** exceed manufacturers recommendation for maximum performance, as this could cause the motor to overheat.

Secure the pump in its operating position so it cannot tip over, fall or slide.

**DO NOT** pump without safety devices in place.

For hazardous locations, use pumps that are listed and classified for such locations.

Basin must be vented in accordance with the local plumbing codes.

IMPORTANT: Hydromatic is not responsible for losses, injury or death resulting from failure to observe these safety precautions, misuse or abuse of pumps or equipment.

## CONTROL PANELS

All Hydromatic control panels used on these grinders are UL listed and CSA certified. Control panels mounted directly to the basin used outdoors are UL listed and CSA certified waterproof.

If intrinsically safe controls used in hazardous locations are required, Hydromatic can furnish a UL listed or CSA certified panel.

Note: Hydromatic built control panels supply the correct circuitry for moisture and heat sensor connections. Failure to install the correct circuitry with proper connection would negate warranty and Factory Mutual Approval.

## LEVEL SENSING CONTROLS

Intrinsically-safe type float controls are recommended for all applications and required for hazardous location service. An intrinsically safe control panel relay will limit the current and voltage to the level controls. A Hydromatic control panel can be supplied with this type circuitry. The float level controls maintain the basin sewage water level by controlling pump turn-on and turn-off level.

1. The lower turn-off control should be set so that the pump stops at approximately the top of the pump.
2. The upper turn-on control should be set above the lower turn-off control. The exact height between the two controls is determined by the number of pump starts desired and the depth of the basin. A maximum of 10 starts per hour should not be exceeded.
3. The override control is set at a specified height above the upper turn-on control.
4. The alarm control is set about 6" to 12" above the override control.
5. No control should be set above the inlet invert.

## JUNCTION BOXES

If a junction box is used in a hazardous location, it must be a hazardous location approved type with hazardous location cord connectors. Wires from the junction box must pass through a hazardous location seal connector.

## AIR VENTING

Air tends to trap in the pump volute when water raises in the sump or when the pump is lowered into water after service. To vent off this air, a small hole is drilled into the pump volute. Be sure this vent hole is clean after any service work on pump.

PUMP MODELS: The HWG(X) 200 models are offered in 208 and 230 volt single phase and 208, 230, 460 and 575 three phase. They are offered in 50 and 60 Hz configurations.

INSTRUCTIONS: Instructions cover only the pump unit. Separate instructions for the electrical control panel and basin packaged system are included with these items.

**CAUTION** PUMP IS ONLY TO BE DISASSEMBLED AT Hydromatic FACTORY OR AN AUTHORIZED HYDROMATIC SERVICE FACILITY.

# INSTALLATION & OPERATION

---

## DESCRIPTION OF PUMP

This pump is intended to grind and pump all normal sewage for home or commercial use.

Pump is of heavy duty construction and submersible type for long life when pumping ground sewage. Motor is capacitor start, capacitor run for single phase. Capacitors and start relay are mounted in electrical control box.

Pump has two oil-filled chambers: (1) the motor and ball bearings and (2) the seal chamber - for long life and best heat transfer.

The lower seal above the pump impeller acts as a buffer for upper seal that holds oil in the motor chamber. If lower seal leaks for any reason, water enters the seal chamber. If motor has the seal leak detector, the electrode will contact the water and close the circuit to the red seal light in the control panel indicting motor must be serviced before upper seal fails.

A heat sensor is attached to stator winding to sense any abnormal heat. If motor temperature for any cause rises above 221°F the pump is immediately stopped and will not restart until motor cools to a safe temperature.

**PUMP CORDS:** Each pump has two cords. The power cord contains 4 conductors and the control cord has 5 conductors.

The power cord for single phase uses the color coding for start and main windings and connects to control box terminal strip black (common), white (run), and red (start). The green wire is always ground and connects to ground terminal in control box. For three phase the same 4 conductor color coded cords are used, the black, white and red can be connected to any of the three phase terminals in the control box.

The smaller control cord uses black and white leads for heat sensor and connects to terminal strip in control box. The red and orange wires connect to seal failure terminals in control box and the green or ground lead connects to ground terminal in control box.

**CAUTION** After pump is installed NEVER WORK ON MOTOR OR GRINDER UNIT WITHOUT DISCONNECTING MOTOR LEAD WIRES FROM CONTROL PANEL. DO NOT RELY ON OPENING CIRCUIT BREAKER ONLY.

INSTALLING PUMP IN BASIN - Complete installation and piping instructions are included with the basin package.

THREE PHASE - When pump is installed to operate on three phase power, pump rotation must be checked. For inside installation where control box is near the sump basin, pump can be laid on side to check rotation before installing in sump.

To check rotation turn Hand-Off-Auto switch to OFF position and turn on circuit breaker. Quickly turn H-O-A switch to HAND position, then OFF. Note grinder impeller rotation. Impeller must rotate counterclockwise. If rotation is wrong, change any two line leads to motor at control box terminal. Recheck for proper rotation.

**CAUTION** KEEP HANDS COMPLETELY AWAY FROM GRINDER IMPELLER WHEN MAKING THIS CHECK.

Where pump is installed remote from control box in outside installation a different method is used.

Set the pump in the basin and run in some water so pump can operate. Turn H-O-A switch to hand position and let pump pull water down in basin. When water reaches the bottom of pump, rotation of the water can be observed. Water should rotate in a clockwise direction if pump rotation is correct. If not correct rotation, interchange any two line leads to motor at control panel.

When replacing a pump with a new unit, rotation must be checked.

# HWG(X) PUMP PARTS LIST

Ref No.	Part No.	Description	Qty.
1	22407C102	Cord Cap	1
2	19100A029	Cap Screw, 5/16"-18 x 1" Lg.	8
3	12672A880*	Double Lever Nut	4-7
	12672A885*	Triple Lever Nut	0-4
4	10649A102	Tube, Plastic	2
5	19100A012	Cap Screw, 5/16"-18 x 1-1/4" Lg.	8
6	05876A122*	Gasket, Rubber Tetraseal	1
7	21570B100X	Cap, Upper Bearing	1
8	05876A123*	Gasket, Rubber Tetraseal	1
9	05022A092	Pipe Plug, 1/4" NPT, Hex HD.	2
10	05434A043	Screw, Mach., #10-24 x 1/2" Lg.	1
11	06107A015	Lock Washer, #10	1
12	07597A017	Screw, Mach., Flat Hd.	2
13	21571D100X	Housing Motor	1
14	05013A039	Set Screw, 1/4"-20 x 3/8" Lg.	2
15	19331A005*	Washer, Spring	2
16	08565A013*	Bearing, Ball	1
17	11816A006	Ring Retaining	1
18	21572C100	Rotor, w/Shaft 1ø	1
	21572C101	Rotor, w/Shaft 3ø	1
19	21573C104	Stator 208/1ø	1
	21573C100	Stator 230/1ø	1
	21573C102	Stator 208/230/460/3ø	1
	21573C103	Stator 575/3ø	1
20	08565A018*	Bearing, Ball	1
21	21574D100X	Housing, Upper Seal	1
22	21576A010*	Seal, 7/8" Shaft	2
23	12558A006*	Ring Retaining	1
24	22578A004*	Electrode	2
25	05876A125*	Gasket, Rubber Tetraseal	2
26	22579A000*	Ferrule, Rubber	1
27	21577A000*	Plug, Special	1
28	21578C100X	Housing, Lower Seal	1
29	22581A001*	Gasket, Vellumoid	1
30	21580D102P	Casing, Volute	1
31	28201C301	Pump Impeller, HWG200/HWGX200	1
	28201C305	28201C305 Pump Impeller, *F Series Only 1	1
32	21582B000	Impeller, Grinding	1
33	07597A018*	Mach. Screw, 1/4"-20 x 1" Lg.	1
34	21583A000*	Retainer, Impeller	1
35	21584B000	Flange w/Shredding Ring, WG20/X	1
36	19099A012	Cap Screw, Hex 1/4"-20 x 1" Lg.	3

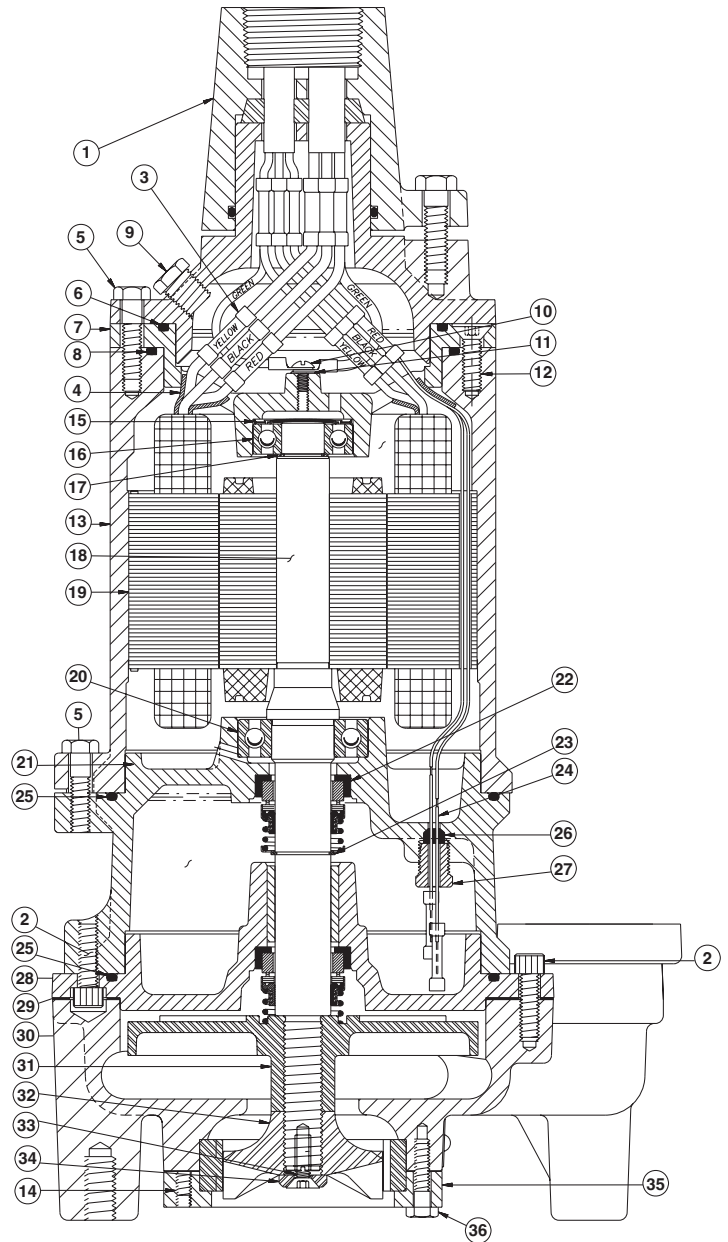

Items with \* are included in repair kit 25218A003

# TROUBLESHOOTING

## CHECK LIST TO DETERMINE MOTOR TROUBLE

### CHECKING FOR MOISTURE IN MOTOR:

Use ohmmeter and set on highest scale. Readings on the large power cord between any of the conductors red, black, white to green conductor or motor shell should be more than 500,000 ohms.

Both motor housing and stator must be replaced as a unit as stator is pressed in at the factory and cannot be removed in the field.

### RESISTANCE OF WINDINGS:

Every motor winding has a fixed resistance and winding must check close to the specification values. This winding resistance also determines if motor is connected for voltage being used.

Use ohmmeter for this test and set on scale to read directly in ohms.

### WINDING RESISTANCE VALUES IN OHMS (MARATHON)

Motor Type & Voltage	Black To White Main Winding	Black To Red Main Winding	White to Red
Single Phase, 208V	1.2	4.87	6.07
Single Phase, 230V	1.54	7.60	9.14
Three Phase, 200V	2.79	2.79	2.79
Three Phase, 230V	3.29	3.29	3.29
Three Phase, 460V	13.15	13.15	13.15
Three Phase, 575V	19.68	19.68	19.68

## TROUBLE CHECK LIST

Troubles listed below are generally not caused by the pump. Other trouble can occur from faulty control box operation. These will be listed with the control box instructions.

CONDITION	PROBABLE CAUSE
Pump runs but does not pump liquid from basin.	<ol style="list-style-type: none"> <li>Pump impeller may be air locked, this occasionally occurs on a new installation. Remove pump and clean volute case weep hole and reinstall pump allowing 2 to 3 minutes for air to weep from pump.</li> <li>Remove pump and guides from wet well, and test in 5 gallon bucket after checking weep hole again. If pump still does not pump, disassemble check valve and check to insure that check valve flapper has not adhered to sealing face. This condition results from assembled basin units setting in the sun before installation. NOTE: Check valve bolts should have Loctite 242 or equivalent applied before reassembly of check valves.</li> <li>If pump will pump water from bucket, try in wet well again. If it still will not pump, the following problems may exist:               <ol style="list-style-type: none"> <li>Ball Valve - Gate Valve may be in off position.</li> <li>Discharge piping obstructed</li> <li>Valve at street or in main line may be off - redundant check valve in backwards.</li> <li>Tap at force main obstructed - hole not drilled through enough - pipes pushed into tee too far.</li> </ol> </li> <li>If pump has been installed for some time and does not pump, it may be clogged at grinder inlet.</li> <li>Discharge head may be too high. Check elevation. Maximum pump head at zero flow is 105 feet.</li> <li>If above checks do not locate trouble, motor rotor may be loose on shaft which allows motor to run but will not turn impeller or only at low RPM.</li> </ol>
Red light comes on at control box.	<ol style="list-style-type: none"> <li>This indicates some water has leaked past the lower seal and has entered the seal chamber and made contact with the electrode probe. Pump must be removed from basin immediately for replacement of lower seal. This preventative repair will save an expensive motor.</li> </ol>
Overload trips and alarm buzzer or flashing red light comes on due to high water level in basin.	<ol style="list-style-type: none"> <li>Push in red reset button to reset overload. If overload trips again after short run, pump has some damage and must be removed from basin for checking.</li> <li>Trouble may be from clogged grinder causing motor to overload or could be from failed motor.</li> <li>Trouble may be from faulty component in control box. Always check control box before removing pump.</li> </ol>

# TROUBLESHOOTING

CONDITION	PROBABLE CAUSE
Yellow run light stays on continuously.	<ol style="list-style-type: none"> <li>1. Indicates H-O-A switch be in the hand position.</li> <li>2. Level control switch may have failed causing pump to continue to operate when water is below lower float.</li> <li>3. Grinder assembly may be partially clogged causing pump to operate at very reduced capacity.</li> <li>4. Check valve may be clogged causing low pump flow. Gate valve or street valve may be in off position.</li> <li>5. Pump may be air locked.</li> </ol>
Circuit breaker trips.	<ol style="list-style-type: none"> <li>1. Reset breaker by pushing clear down on handle then back to "ON" position. If breaker trips again in few seconds it indicates excessive load probably caused by a short in the motor or control box. Check out instructions given with control box before pulling pump.</li> <li>2. If this condition happens after an electrical storm, motor or control box may be damaged by lightning.</li> <li>3. Resistance reading of the motor with lead wires disconnected from the control box can determine if trouble is in motor or control box.</li> </ol>
Pump is noisy and pump rate is low.	<ol style="list-style-type: none"> <li>1. Grinder assembly may be partially clogged with some foreign objects causing noise and overload on the motor.</li> <li>2. Grinder impeller may be rubbing on grinder ring due to bent shaft or misalignment.</li> </ol>
Grease and solids have accumulated around pump and will not pump out of basin.	<ol style="list-style-type: none"> <li>1. Water shut-off level may be set too high or volume of pumping cycle may be too great allowing solids to settle out of suspension. Set pump shut-off level at the pumps widest part where volute case mates with seal chamber - to 1" below. Set water level control (float or weight) to following approx. levels:            2 ft. dia. basin 12" - 14"            3 ft. dia. basin 6" - 8"            4 ft. dia. basin 6" - 7"            above pump shut-off.</li> <li>2. Run pump on hand operation for several minutes with small amount of water running into basin to clean out solids and grease. This allows pump to break suction and surge which will break up the solids. If level switch lower weight or float is set properly this condition generally will not occur.</li> <li>3. Where all type switches are installed trash may have accumulated around lower weight causing pump to turn off too soon. Clean trash from weight and suspension cable.</li> </ol>



# MOTOR WIRING DIAGRAMS

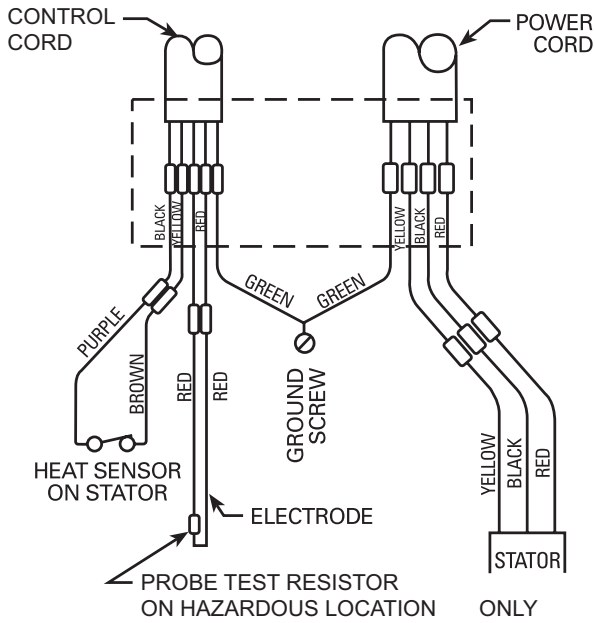

**200 OR 230 VOLT - SINGLE PHASE**

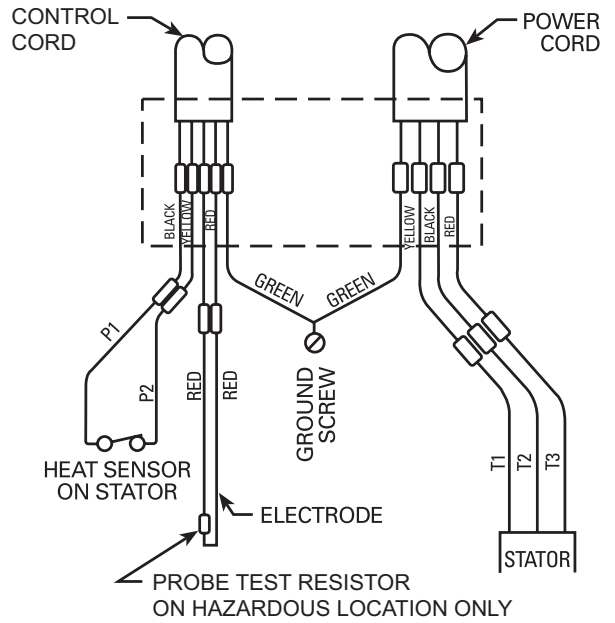

**200 OR 575 VOLT - THREE PHASE**

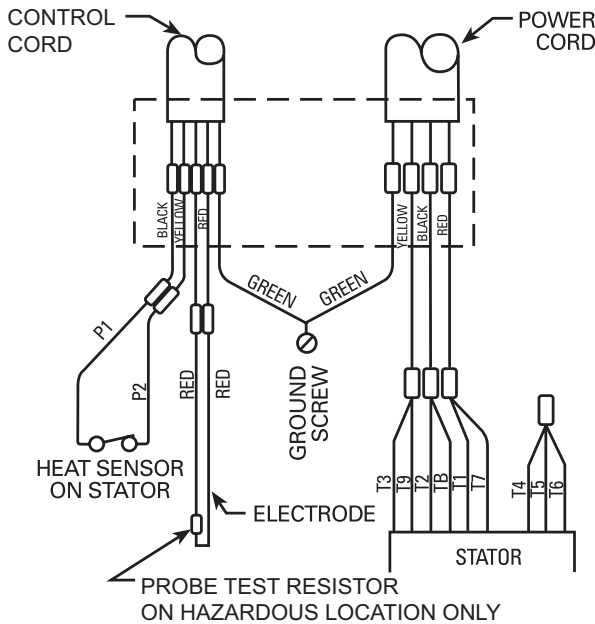

**230 VOLT - THREE PHASE**

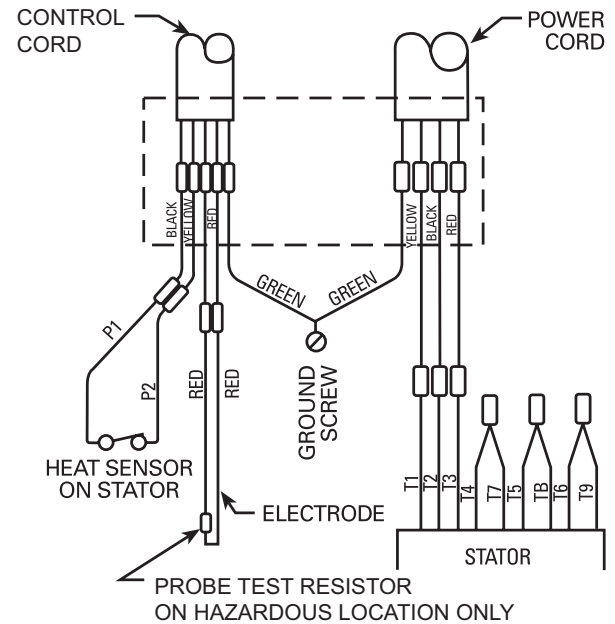

**460 VOLT - THREE PHASE**

**NOTE:** Probe test resistor is used on HWG(X) 200 UL Hazardous Location only.

### STANDARD LIMITED WARRANTY

Pentair Hydromatic® warrants its products against defects in material and workmanship for a period of 12 months from the date of shipment from Pentair Hydromatic or 18 months from the manufacturing date, whichever occurs first – provided that such products are used in compliance with the requirements of the Pentair Hydromatic catalog and technical manuals for use in pumping raw sewage, municipal wastewater or similar, abrasive-free, noncorrosive liquids.

During the warranty period and subject to the conditions set forth, Pentair Hydromatic, at its discretion, will repair or replace to the original user, the parts that prove defective in materials and workmanship. Pentair Hydromatic reserves the right to change or improve its products or any portions thereof without being obligated to provide such a change or improvement for prior sold and/or shipped units.

Start-up reports and electrical schematics may be required to support warranty claims. Submit at the time of start up through the Pentair Hydromatic website: <http://forms.pentairliterature.com/startupform/startupform.asp?type=h>. Warranty is effective only if Pentair Hydromatic authorized control panels are used. All seal fail and heat sensing devices must be hooked up, functional and monitored or this warranty will be void. Pentair Hydromatic will cover only the lower seal and labor thereof for all dual seal pumps. Under no circumstance will Pentair Hydromatic be responsible for the cost of field labor, travel expenses, rented equipment, removal/reinstallation costs or freight expenses to and from the factory or an authorized Pentair Hydromatic service facility.

This limited warranty will not apply: (a) to defects or malfunctions resulting from failure to properly install, operate or maintain the unit in accordance with the printed instructions provided; (b) to failures resulting from abuse, accident or negligence; (c) to normal maintenance services and parts used in connection with such service; (d) to units that are not installed in accordance with applicable local codes, ordinances and good trade practices; (e) if the unit is moved from its original installation location; (f) if unit is used for purposes other than for what it is designed and manufactured; (g) to any unit that has been repaired or altered by anyone other than Pentair Hydromatic or an authorized Pentair Hydromatic service provider; (h) to any unit that has been repaired using non factory specified/OEM parts.

Warranty Exclusions: PENTAIR HYDROMATIC MAKES NO EXPRESS OR IMPLIED WARRANTIES THAT EXTEND BEYOND THE DESCRIPTION ON THE FACE HEREOF. PENTAIR HYDROMATIC SPECIFICALLY DISCLAIMS THE IMPLIED WARRANTIES OF MERCHANTABILITY AND FITNESS FOR ANY PARTICULAR PURPOSE.

Liability Limitation: IN NO EVENT SHALL PENTAIR HYDROMATIC BE LIABLE OR RESPONSIBLE FOR CONSEQUENTIAL, INCIDENTAL OR SPECIAL DAMAGES RESULTING FROM OR RELATED IN ANY MANNER TO ANY PENTAIR HYDROMATIC PRODUCT OR PARTS THEREOF. PERSONAL INJURY AND/OR PROPERTY DAMAGE MAY RESULT FROM IMPROPER INSTALLATION. PENTAIR HYDROMATIC DISCLAIMS ALL LIABILITY, INCLUDING LIABILITY UNDER THIS WARRANTY, FOR IMPROPER INSTALLATION. PENTAIR HYDROMATIC RECOMMENDS INSTALLATION BY PROFESSIONALS.

Some states do not permit some or all of the above warranty limitations or the exclusion or limitation of incidental or consequential damages and therefore such limitations may not apply to you. No warranties or representations at any time made by any representatives of Pentair Hydromatic shall vary or expand the provision hereof.

## NOTES

---

---

---

---

---

---

---

---

---

---



1101 Myers Parkway  
Ashland, OH 44805  
Ph: 855.274.8947

490 Pinebush Road,  
Unit 4  
Cambridge, Ontario,  
Canada N1T 0A5  
PH: 800-363-7867

[pentair.com/hydromatic](https://pentair.com/hydromatic)

All indicated Pentair trademarks and logos are property of Pentair. Third party registered and unregistered trademarks and logos are the property of their respective owners.

©2024 Pentair. All Rights Reserved.

HYD12731 / 056255671 (07-15-24)