



HYDROMATIC[®]
MODELS HPGH(X)/HPGHH(X)
SUBMERSIBLE SEWAGE
GRINDER PUMPS

ALSO AVAILABLE FOR HAZARDOUS LOCATION

HPGHX/HPGHHX



HYDROMATIC® MODELS HPGH(X)/HPGHH(X)

Submersible Sewage Grinder Pumps

HPGH(X)/HPGHH(X) Pumps Characteristics					
Pump / Motor Unit	Submersible-Grinder				
Phase	1 Ø		3 Ø		
Horsepower	3	5	3	5	7.5
208V FLA	20.6	33.9	10.9	17.9	24.8
230V FLA	17.9	29.5	9.4	15.6	21.5
460V FLA	N/A	N/A	4.7	7.8	10.8
575V FLA	N/A	N/A	3.8	6.2	8.6
Motor Type	Oil-Cooled Induction Capacitor Start		Oil-Cooled Induction		
RPM	3450				
Temperature	140°F Ambient				
Operation	Intermittent				
Hertz	60 Hz				
Thermal Overload	Bimetallic				
Temperature	Maximum Water 140°F				
NEMA Design	Type L (1 Ø)		Type B (3 Ø)		
Insulation	Class F				
Discharge Size	2" NPT – 3" 125 lb. Flange (Horizontal)				
Unit Weight	225 lbs.				
Power Cord	S00W, W				
Control Cord	S00W				

HPGH(X)/HPGHH(X) Materials of Construction	
Description	Material of Construction
Motor Housing	Cast Iron ASTM-48
Pump Casing	Cast Iron ASTM-48
Coolant / Lubricant	Dielectric Oil
Shaft	Stainless Steel
Mechanical Shaft Seal	Seal Faces: Carbon / Ceramic, Seal Body: Stainless Steel, Spring: Stainless Steel, Bellows: Buna-N
Impeller	Semiopen 5-Vane SST
Cutters	440C Hardened 55-60 Rockwell C
Upper Bearing	[Radial] Single Row-Ball
Lower Bearing	[Thrust] Single Row-Ball
Fasteners	Stainless Steel

HPGH/HPGHH Dimensional Data

Top View – Vertical Discharge Standard

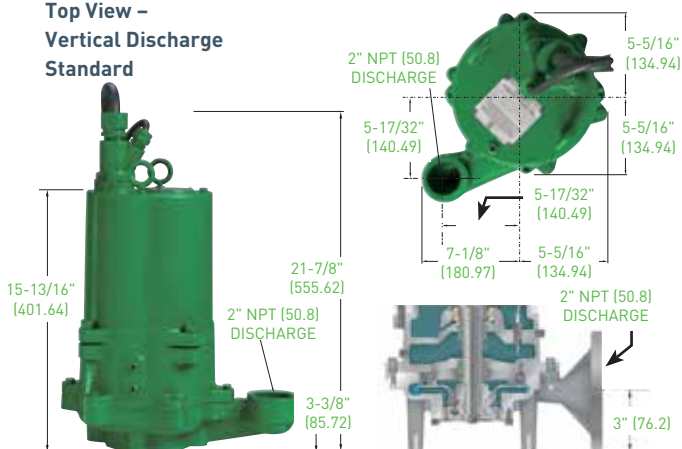

HPGHX/HPGHHX Dimensional Data

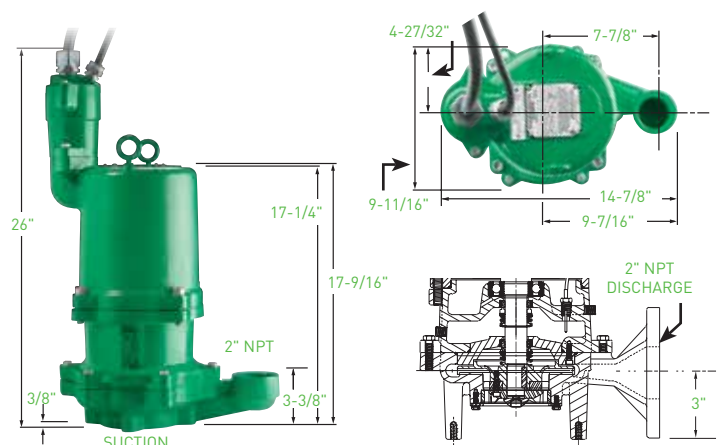

HPGH/HPGHH Pump Features

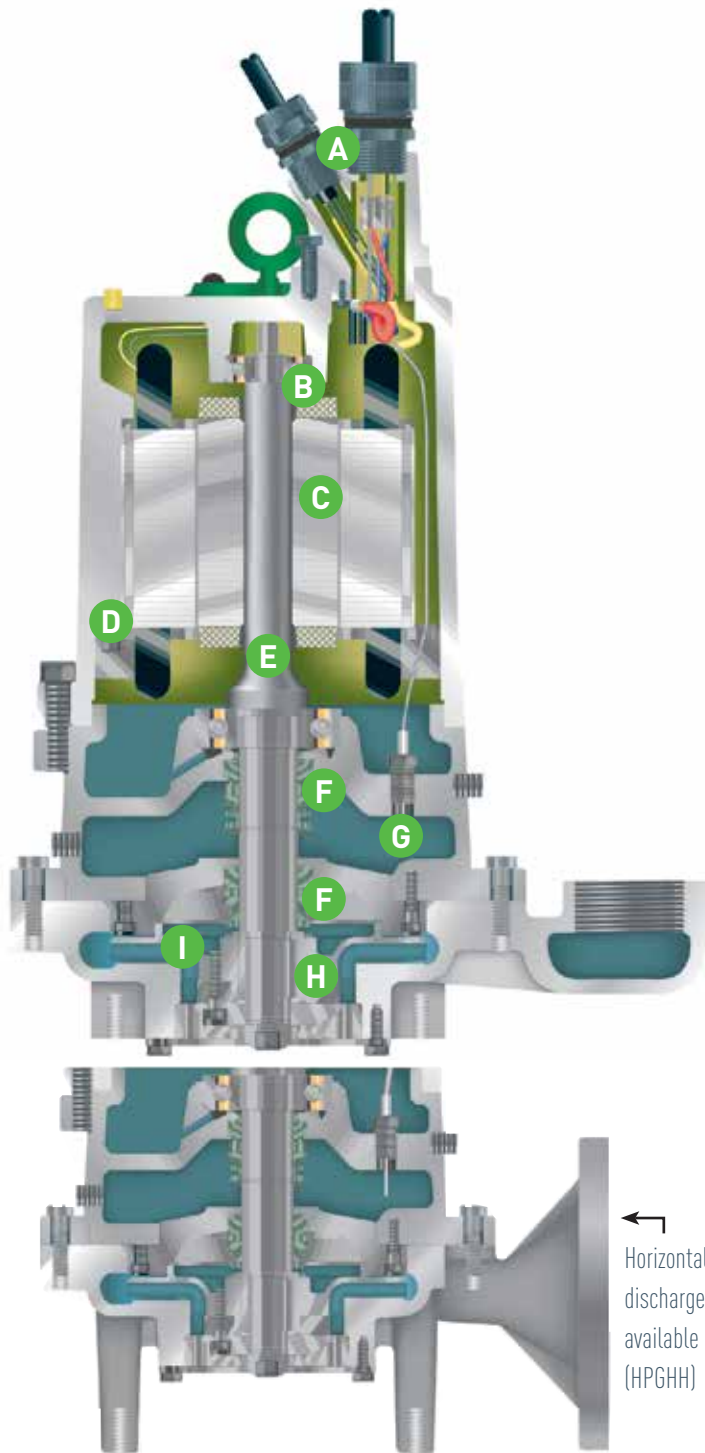

A. Two Barrier Seal

One epoxy barrier and one compression fitting for maximum protection against wicking and water seepage into the motor housing.

B. Bearings

The heavy-duty ball bearings, upper (radial) and lower (thrust), are continuously lubricated by oil to ensure long service life.

C. Motor

Electrical design combines the advantages of high torque output with optimum running efficiency engineered specifically for grinder operation.

D. Stator Bolts

The stator is secured to the motor housing by means of stator bolts and retaining ring which ensure ease of maintenance if the need ever arises.

E. Shaft

Standard stainless steel shaft in grinder pump.

F. Dual Seals

Dual seals for maximum moisture protection.

G. Moisture Probe

Moisture detection probe.

H. Cutters

Exclusive "Dual Cutter" design cuts solids to smallest particle size, thereby greatly reducing clogging, roping, or binding.

I. Impeller

Standard 316 SST / CF8M impeller provides highest level of corrosion resistance and maximum toughness from impact for a wide variety of slurry pumpage.

Horizontal discharge available (HPGHH)

Applications:

Residential, Commercial, Resort Area

HPGHX/HPGHHX Pump Features

A. Three Barrier Seal

One epoxy barrier, one compression fitting and two additional O-rings for maximum protection against wicking and water seepage into the motor housing.

B. Bearings

The heavy-duty ball bearings, upper (radial) and lower (thrust), are continuously lubricated by oil to ensure long service life.

C. Motor

Electrical design combines the advantages of high torque output with optimum running efficiency engineered specifically for grinder operation.

D. Stator Bolts

The stator is secured to the motor housing by means of stator bolts which ensure ease of maintenance if the need ever arises.

E. Shaft

Standard stainless steel shaft in grinder pump.

F. Dual Seals

Dual seals for maximum moisture protection.

G. Two Moisture Probes

Moisture detection probe located in seal chamber.

H. Cutters

Exclusive "Dual Cutter" design cuts solids to smallest particle size thereby greatly reducing clogging, roping, or binding.

I. Impeller

Multivane, semiopen impeller.

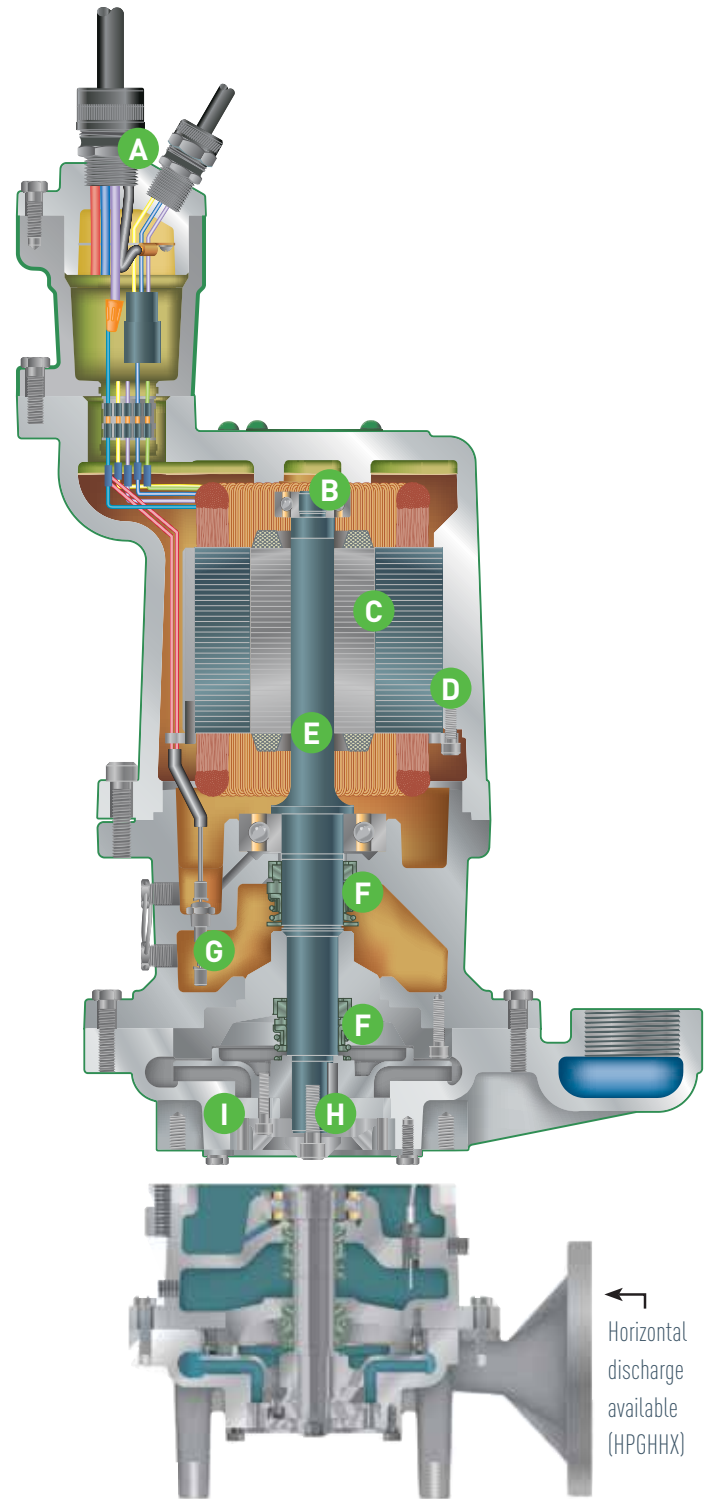

1101 MYERS PARKWAY
ASHLAND, OHIO 44805
PH: 855-274-8947
WWW.HYDROMATIC.COM

490 PINEBUSH ROAD, UNIT 4
CAMBRIDGE, ONTARIO, CANADA N1T 0A5
PH: 800-363-7867
WWW.HYDROMATIC.COM

Because we are continuously improving our products and services, Pentair reserves the right to change specifications without prior notice.
E-02-7100 05/02/17 © 2017 Pentair plc. All Rights Reserved.

Applications:

Municipal, Commercial, Residential, Resort Area