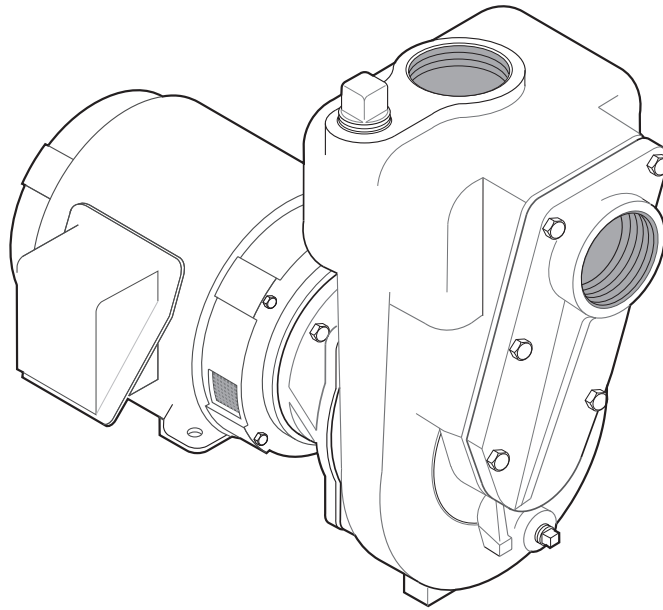

**Close Coupled Motor Drive Self
Priming Centrifugal Pump**

BERKELEY®**B2X, B3T, B4T, B4Z****Important**

For best possible performance and continuous, satisfactory operation, read these instructions before installing your new pump.

Should service be required, this manual can be a valuable guide. It should be kept near the installation for ready reference.

Important Safety Instructions

SAVE THESE INSTRUCTIONS - This manual contains important instructions that should be followed during installation, operation, and maintenance of the product. Save this manual for future reference.

⚠ This is the safety alert symbol. When you see this symbol on your pump or in this manual, look for one of the following signal words and be alert to the potential for personal injury!

⚠ DANGER indicates a hazard which, if not avoided, *will* result in death or serious injury.

⚠ WARNING indicates a hazard which, if not avoided, *could* result in death or serious injury.

⚠ CAUTION indicates a hazard which, if not avoided, *could* result in minor or moderate injury.

NOTICE addresses practices not related to personal injury.

The manufacturer cannot anticipate every possible circumstance that might involve a hazard. The warnings in this manual, and the tags and decals affixed to the unit are, therefore, not all-inclusive. If you use a procedure or operating technique that the manufacturer does not specifically recommend, you must satisfy yourself that it is safe for you and others. You must also make sure that the procedure or operating technique that you choose does not render the system unsafe.

To avoid risk of serious bodily injury and property damage, read and follow all safety instructions in this manual and on equipment carefully before installing this pump. Keep safety labels in good condition; replace if missing or damaged.

Electrical Safety

⚠ WARNING Risk of electric shock. Can shock, burn or kill. All wiring should be done by a qualified electrician.

- Wire motor for correct voltage. See "Electrical" section of this manual and motor nameplate.
- Ground motor before connecting to power supply.
- Meet National Electrical Code and local codes for all wiring.
- Follow wiring instructions in this manual when connecting motor to power lines.

General Safety

⚠ WARNING Risk of explosion. The pump body may explode if used to boost pressure above 100 psi (689 kPa). Do not use this pump with inlet pressure greater than 70 psi (483 kPa). If not already in the piping system, install a pressure relief valve in the pump discharge line capable of passing the full pump flow at 100 psi (689 kPa). If local code requires installation of a pressure relief valve capable of handling the full pump flow at a pressure less than 100 psi (689 kPa), follow the code requirements.

⚠ WARNING Risk of fire or explosion. To avoid risk of fire and explosion, Pump Water Only with this pump. Do not pump salt water, flammable liquids or chemicals. Do not use the pump near gas pilot lights or where chemical or gas fumes are present. Use of an electric pump with liquids other than water or in an atmosphere containing chemical or gas fumes may ignite those liquids or gases and cause injury or death due to an explosion and/or fire.

⚠ WARNING Heavy parts. NEVER walk or reach under a suspended pump.

- DO NOT screw an eye bolt into the motor housing and attempt to lift assembly! The lifting point built into the motor case is not designed to support the combined weight of the motor and pump.
- The crane or hoist must have a capacity in excess of the combined weight of the motor and pump.

⚠ CAUTION Risk of burns. If water is trapped in the pump during operation it may turn to steam. Trapped steam can lead to an explosion and burns. Never run the pump with the outlet closed or obstructed.

⚠ CAUTION Risk of freezing. Do not allow pump, piping, or any other system component containing water to freeze. Freezing may damage system, leading to injury or flooding. Allowing pump or system components to freeze will void warranty.

Pump approved liquids only with this pump.

Periodically inspect pump and system components.

Wear safety glasses at all times when working on pumps.

Keep work area clean, uncluttered and properly lighted; store properly all unused tools and equipment.

Keep visitors at a safe distance from the work areas.

Make workshops childproof; use padlocks and master switches; remove starter keys.

California Proposition 65 Warning

⚠ WARNING This product and related accessories contain chemicals known to the State of California to cause cancer, birth defects or other reproductive harm.

Limited Warranty

BERKELEY warrants to the original consumer purchaser (“Purchaser” or “You”) of the products listed below, that they will be free from defects in material and workmanship for the Warranty Period shown below.

Product	Warranty Period
Water Systems:	
Water Systems Products — jet pumps, small centrifugal pumps, submersible pumps and related accessories	<i>whichever occurs first:</i> 12 months from date of original installation, or 18 months from date of manufacture
Pro-Source™ Composite Tanks	5 years from date of original installation
Pro-Source™ Steel Pressure Tanks	5 years from date of original installation
Pro-Source™ Epoxy-Lined Tanks	3 years from date of original installation
Sump/Sewage/Effluent Products	12 months from date of original installation, or 18 months from date of manufacture
Agricultural/Commercial:	
Centrifugals – close-coupled motor drive, frame mount, SAE mount, engine drive, VMS, SSCX, SSHM, solids handling, submersible solids handling	12 months from date of original installation, or 24 months from date of manufacture
Submersible Turbines, 6” diameter and larger	12 months from date of original installation, or 24 months from date of manufacture

Our limited warranty will not apply to any product that, in our sole judgement, has been subject to negligence, misapplication, improper installation, or improper maintenance. Without limiting the foregoing, operating a three phase motor with single phase power through a phase converter will void the warranty. Note also that three phase motors must be protected by three-leg, ambient compensated, extra-quick trip overload relays of the recommended size or the warranty is void.

Your only remedy, and BERKELEY’s only duty, is that BERKELEY repair or replace defective products (at BERKELEY’s choice). You must pay all labor and shipping charges associated with this warranty and must request warranty service through the installing dealer as soon as a problem is discovered. No request for service will be accepted if received after the Warranty Period has expired. This warranty is not transferable.

BERKELEY SHALL NOT BE LIABLE FOR ANY CONSEQUENTIAL, INCIDENTAL, OR CONTINGENT DAMAGES WHATSOEVER. THE FOREGOING LIMITED WARRANTIES ARE EXCLUSIVE AND IN LIEU OF ALL OTHER EXPRESS AND IMPLIED WARRANTIES, INCLUDING BUT NOT LIMITED TO IMPLIED WARRANTIES OF MERCHANTABILITY AND FITNESS FOR A PARTICULAR PURPOSE. THE FOREGOING LIMITED WARRANTIES SHALL NOT EXTEND BEYOND THE DURATION PROVIDED HEREIN.

Some states do not allow the exclusion or limitation of incidental or consequential damages or limitations on the duration of an implied warranty, so the above limitations or exclusions may not apply to You. This warranty gives You specific legal rights and You may also have other rights which vary from state to state.

This Limited Warranty is effective June 1, 2011 and replaces all undated warranties and warranties dated before June 1, 2011.

In the U.S.: BERKELEY, 293 Wright St., Delavan, WI 53115
In Canada: 269 Trillium Dr., Kitchener, Ontario N2G 4W5

Motor / Pump Lifting Procedure:

⚠ WARNING Heavy parts. NEVER walk or reach under a suspended pump. DO NOT screw an eye bolt into the motor housing and attempt to lift assembly!

The crane or hoist must have a capacity in excess of the combined weight of the motor and pump. Use a minimum of two chains or straps to lift motor/pump assembly. Each chain or strap must have a capacity in excess of the combined weight of the motor and pump.

Wrap the first chain or strap under the fan end of the motor up tight against the motor feet, and the second chain or strap under the pump bracket between the pump end and the motor.

Raise motor/pump assembly slowly to ensure that the chains or straps will not slip when put under tension. Balance motor and pump with chains or straps to maintain proper weight distribution. If not balanced, release tension on the chains or straps and readjust.

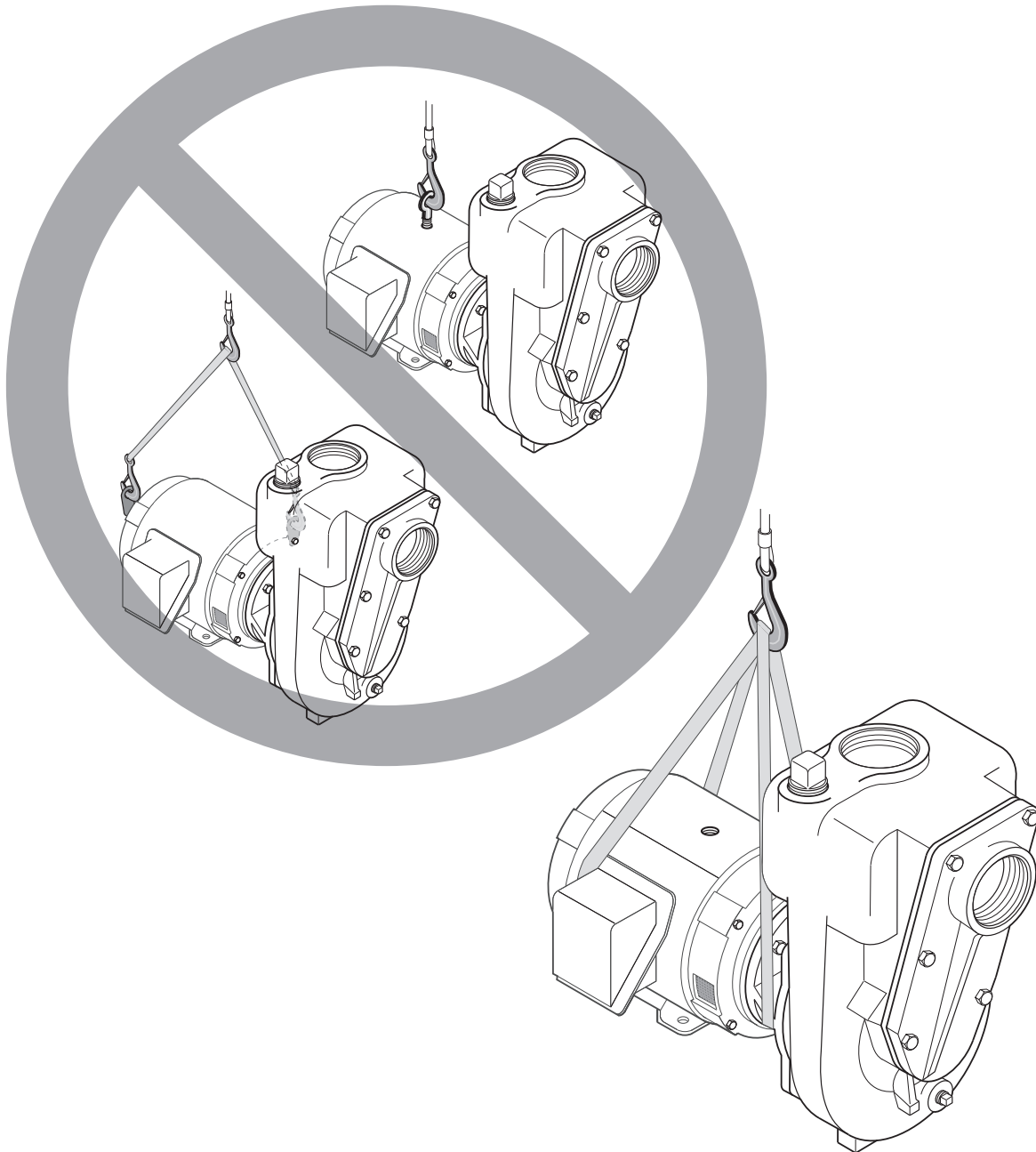

Figure 1 - Lifting the assembly

Location

Locate the pump as near the water source as practical. Make the pipe run as short and straight as possible, especially if a suction lift is required.

Careful attention should be taken to assure that net positive suction head available (NPSHA) exceeds net positive suction head required (NPSHR) by the pump or reduced performance and severe pump damage may result. If in doubt, check with your nearest Berkeley professional dealer. Install pump in a clean, dry and drained location readily accessible for inspection and maintenance. Provide ample ventilation.

Pump Foundation

⚠ WARNING Heavy parts. Use care and proper equipment when handling pump for installation. Pump should be set on a concrete foundation which is sufficiently substantial to absorb vibration and which provides a permanent and rigid support.

There are several types of permanent pump / foundation installations in use. Those pictured here are typical.

- If grout is used, top of concrete should be left rough to provide a good bonding surface.
- Foundation should slope away from pump to prevent liquid from pooling.

Piping

System piping should be at least one commercial pipe size larger than pump connections and flow velocity should not exceed eight (8) feet per second.

NOTICE Take care to align piping with pump case. Misalignment or excessive pipe strain can cause distortion of pump components resulting in rubbing, breakage and reduced pump life.

Support pipe in such a way that no force is exerted on pump connections. Check alignment as follows: with the pump shut down and isolation valves closed, remove pipe flange bolts. If the mating flanges come apart or shift, misalignment is present and causing pressure on the connections. Adjust pipe supports until flanges mate without any force. This procedure can be done throughout piping system.

Refer to the following pages for recommended and not recommended practices in suction connections in centrifugal installations.

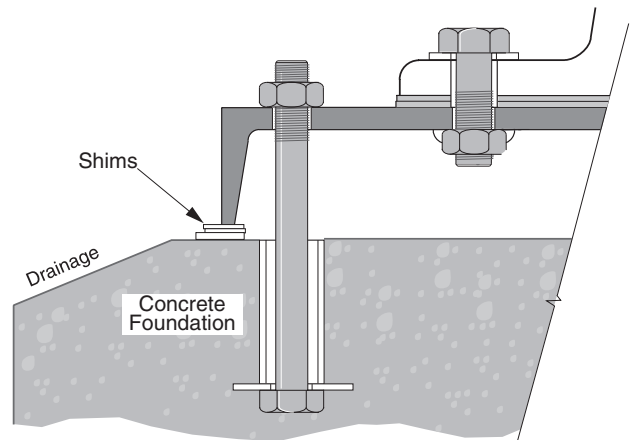
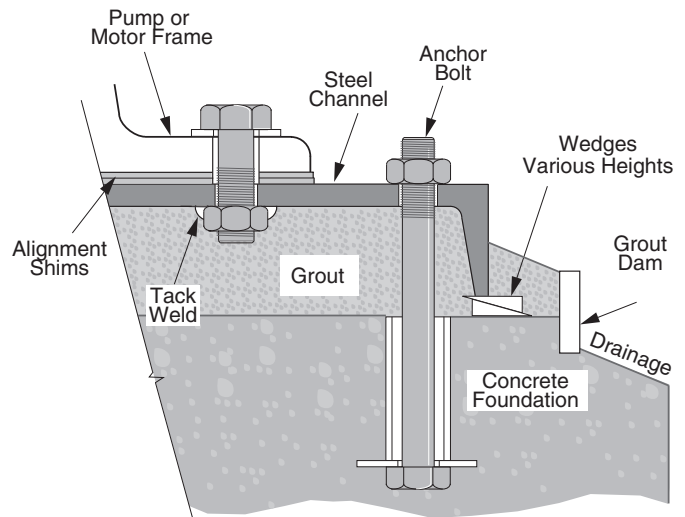
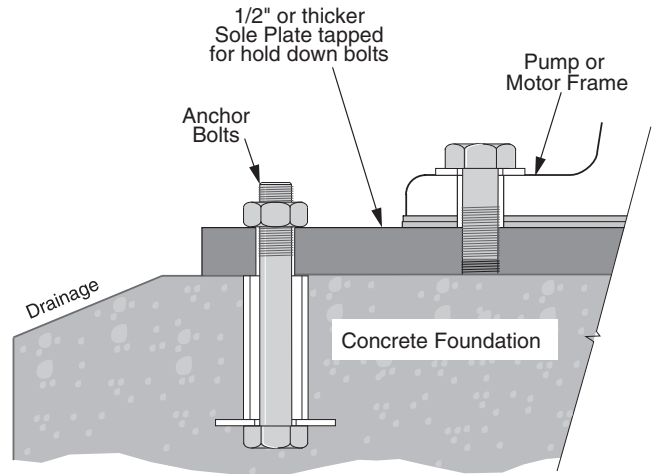

Recommended

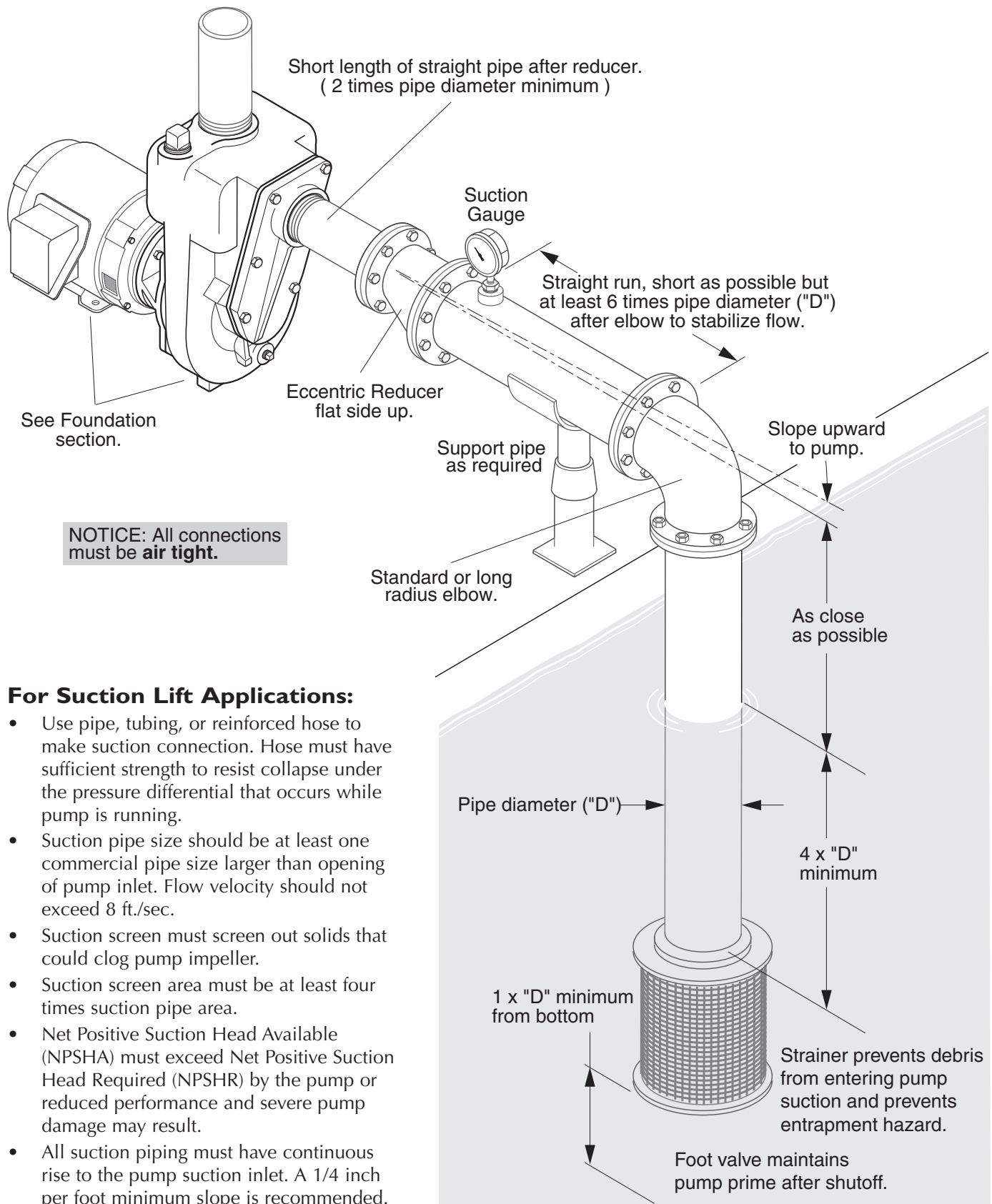

For Suction Lift Applications:

- Use pipe, tubing, or reinforced hose to make suction connection. Hose must have sufficient strength to resist collapse under the pressure differential that occurs while pump is running.
- Suction pipe size should be at least one commercial pipe size larger than opening of pump inlet. Flow velocity should not exceed 8 ft./sec.
- Suction screen must screen out solids that could clog pump impeller.
- Suction screen area must be at least four times suction pipe area.
- Net Positive Suction Head Available (NPSHA) must exceed Net Positive Suction Head Required (NPSHR) by the pump or reduced performance and severe pump damage may result.
- All suction piping must have continuous rise to the pump suction inlet. A 1/4 inch per foot minimum slope is recommended.

NOT Recommended

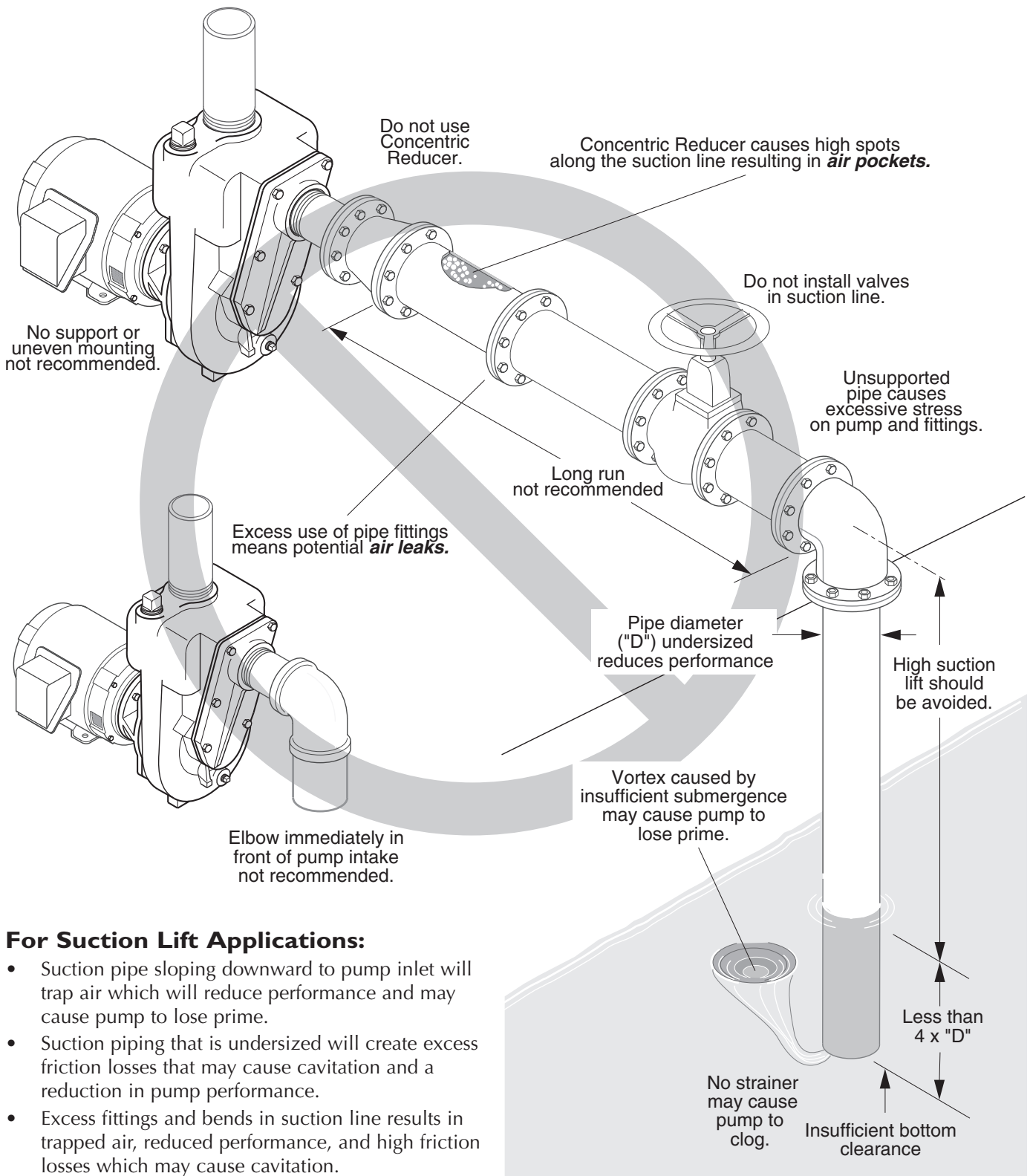

For Suction Lift Applications:

- Suction pipe sloping downward to pump inlet will trap air which will reduce performance and may cause pump to lose prime.
- Suction piping that is undersized will create excess friction losses that may cause cavitation and a reduction in pump performance.
- Excess fittings and bends in suction line results in trapped air, reduced performance, and high friction losses which may cause cavitation.

⚠ DANGER Risk of suction entrapment. Strainer must be used.

Recommended

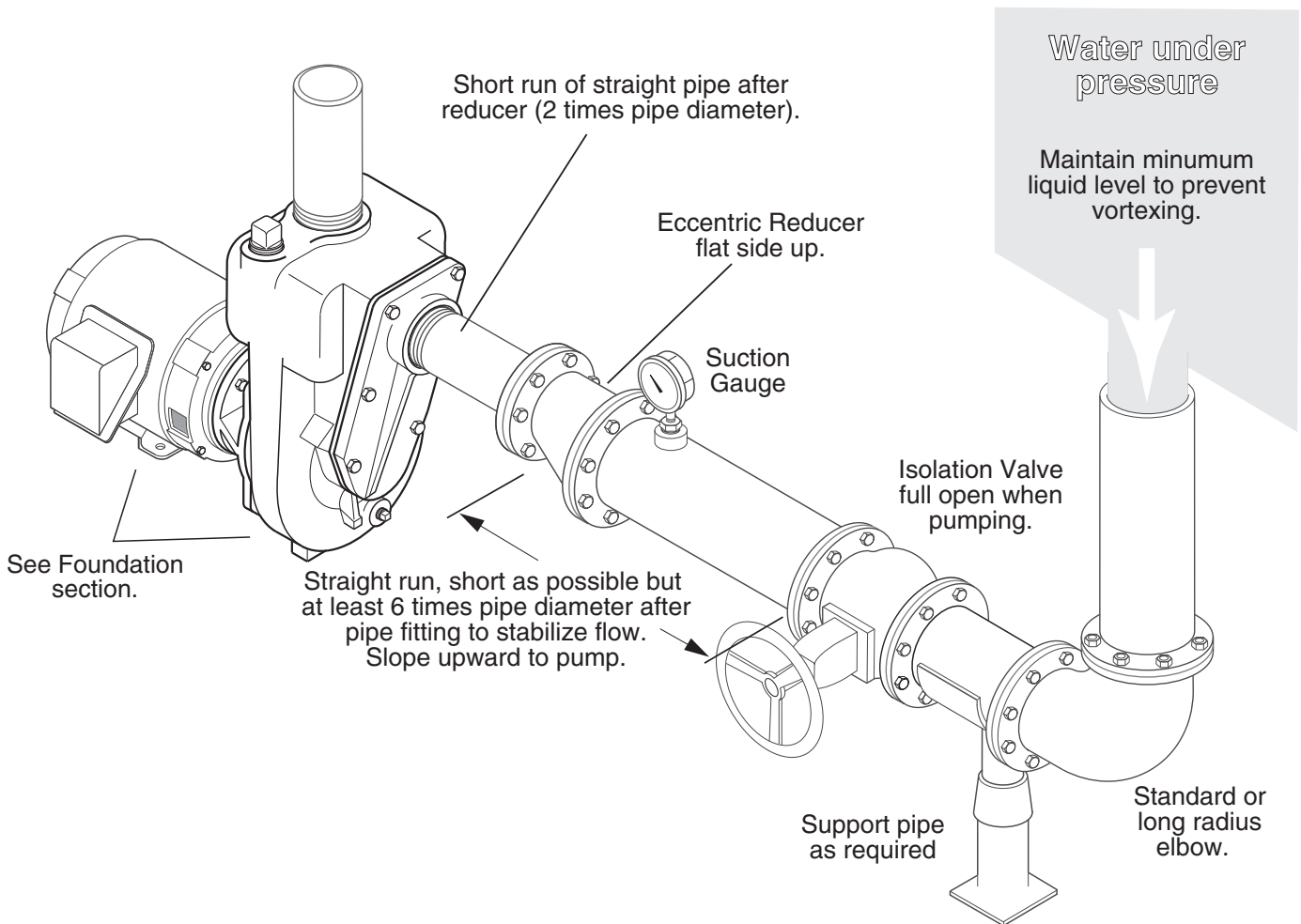

For Flooded Suction Applications:

- Use pipe, tubing, or reinforced hose to make suction connection. Hose must have sufficient strength to resist collapse under the atmospheric pressure differential that may occur while pump is running.
- It is important, even with a flooded suction condition, that proper pipe fittings are used so water is delivered to impeller eye with a smooth flow and consistent velocity.
- Suction pipe size should be at least one commercial pipe size larger than opening of pipe inlet. Flow velocity should not exceed 8 ft./sec.
- An isolation valve is used in a pressurized suction pipe to permit servicing pump.
- Piping run and connection fittings should be properly aligned and independently supported to reduce strain on pump case.
- If solids are present, a strainer should be used to protect the pump.

NOT Recommended

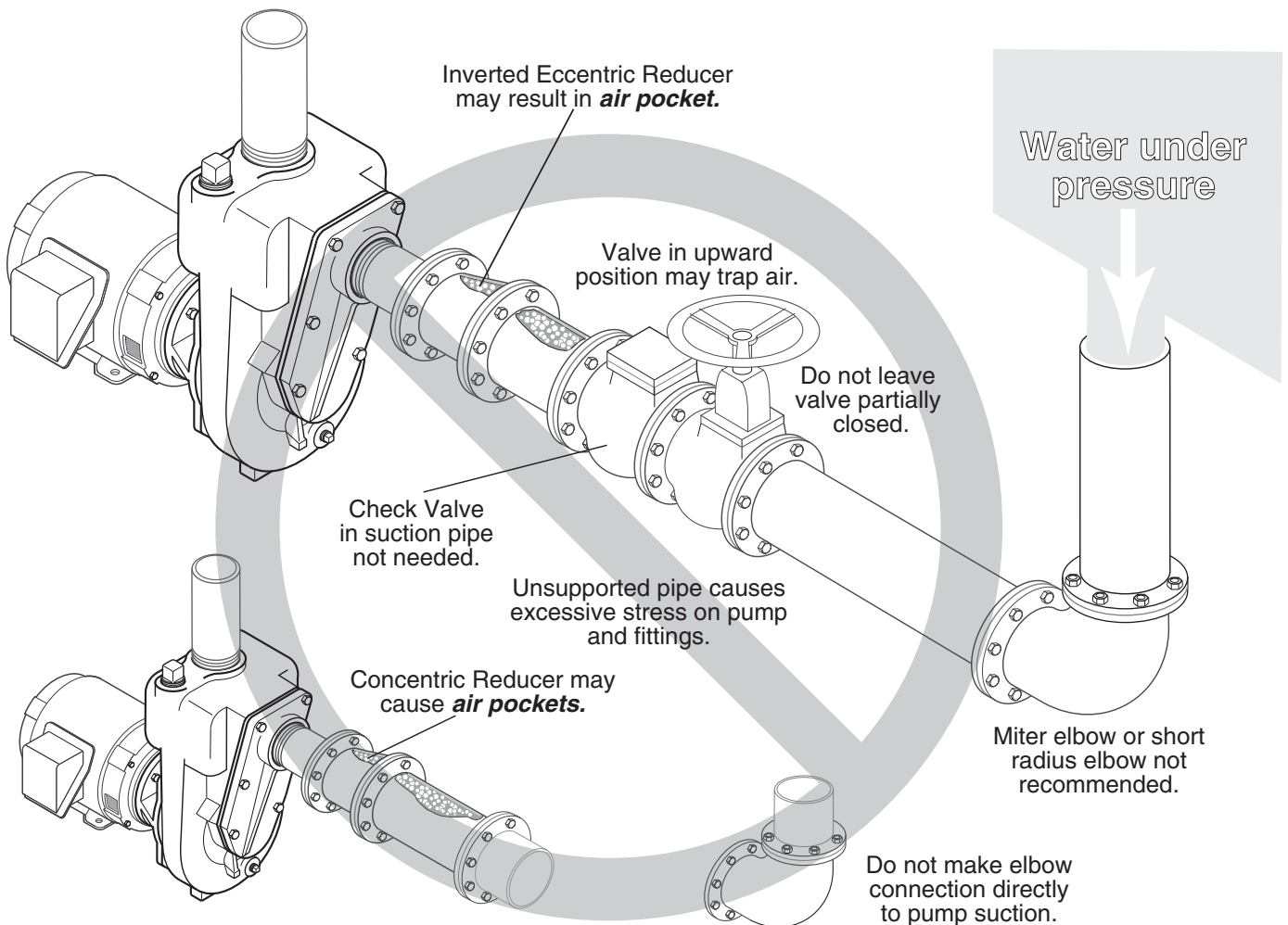

For Flooded Suction Applications:

- Suction piping that is undersized will create excess friction losses that may cause cavitation and a reduction in pump performance.
- Excess fittings and bends in suction line results in trapped air, reduced performance, and high friction losses which may cause cavitation.
- If check valve is required for back flow prevention, locate on the discharge side of pump.

Recommended

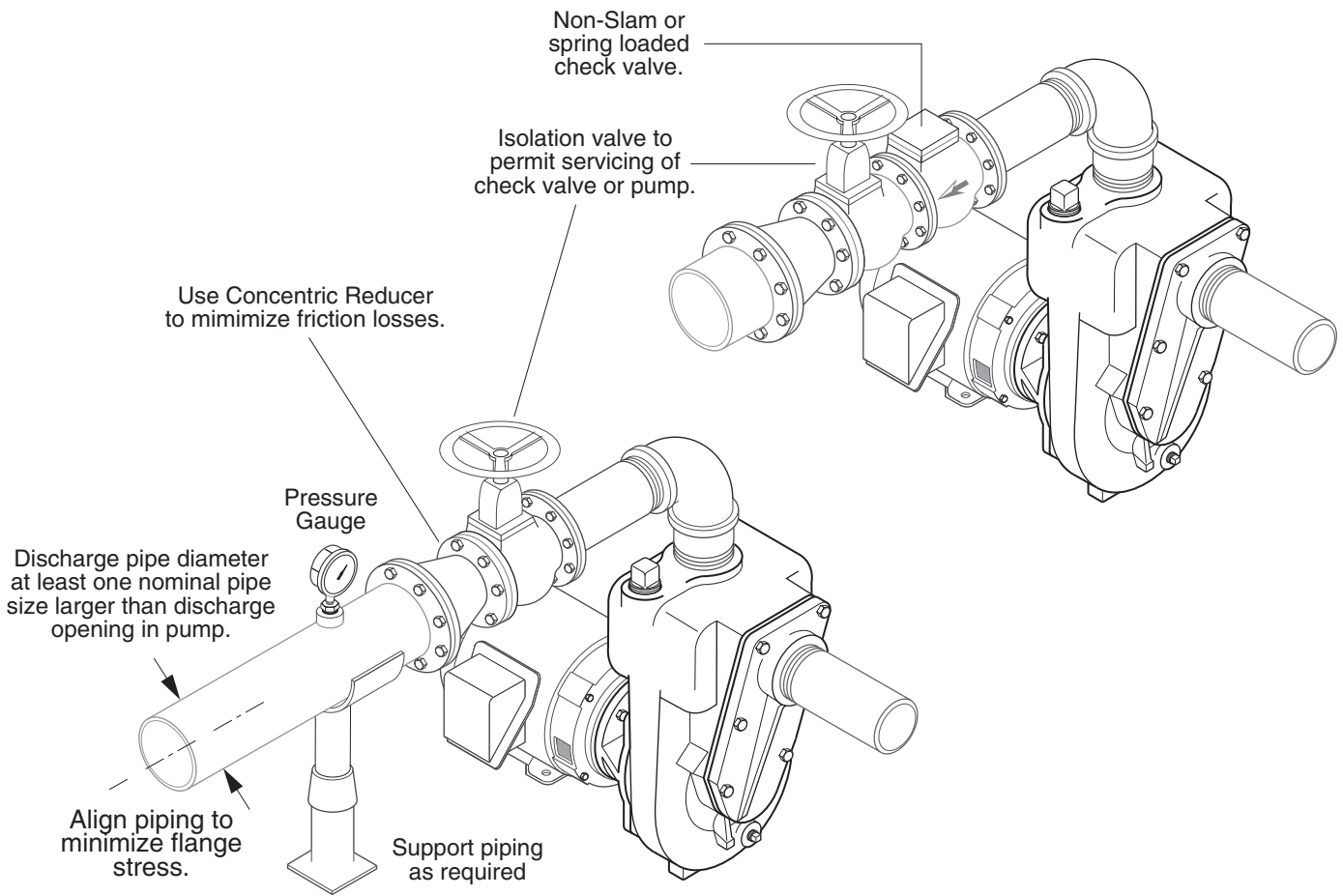

For Discharge Connection:

- Use pipe, tubing or reinforced hose to make discharge connection. Material selected must have sufficient strength for operating pressures.
- Discharge pipe should be sized so that flow velocity is below 8 feet per second.
- Use ONLY non-slamming check valves to prevent hydraulic shock (water hammer).
- Use gate, ball, or butterfly valve for isolation. Valve should be full open during operation.
- Maintain proper pipe size throughout discharge system, using as few elbows and tees as possible to keep friction loss to a minimum.
- Install pressure gauge after reducer as shown to check operating pressure or shut-off head.

NOT Recommended

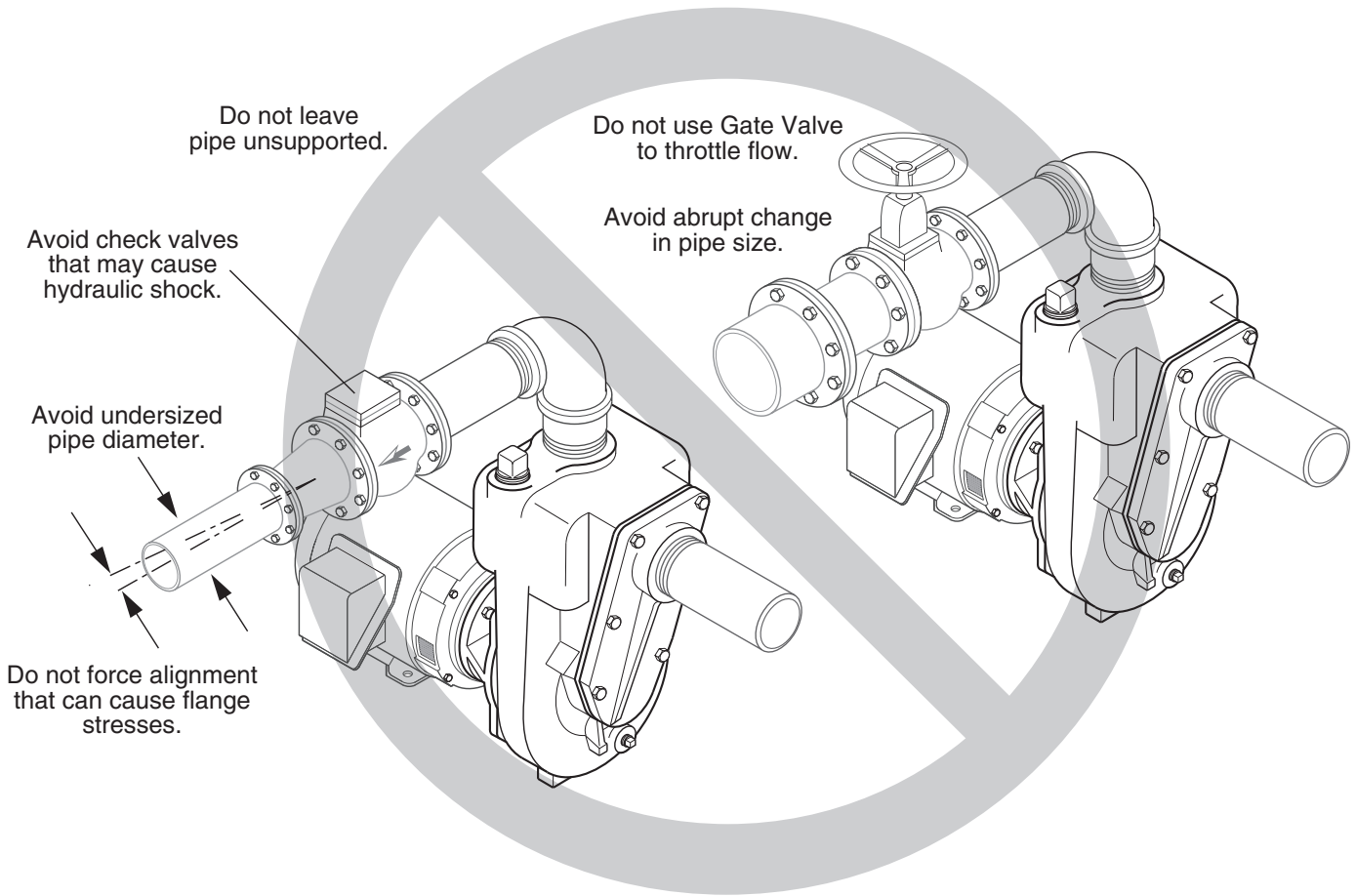

For Discharge Connection:

- Avoid excess friction loss caused by numerous fittings, insufficient pipe diameter, and sharp turns in pipe run.
- Swing type check valves can permit build-up of reverse velocity before closing causing hydraulic shock or "water hammer."

Electrical Connection

⚠ WARNING Risk of electric shock. Can shock, burn or kill. All wiring should be done by a qualified electrician.

- Disconnect power to pump before servicing.
- Check voltage and phase stamped on pump motor nameplate before wiring. Be sure they agree

with your electric current supply. They **MUST** be the same. If in doubt, check with your local power company.

- Refer to the illustration below for minimum recommended pumping panel components that help safeguard your pump during operation.

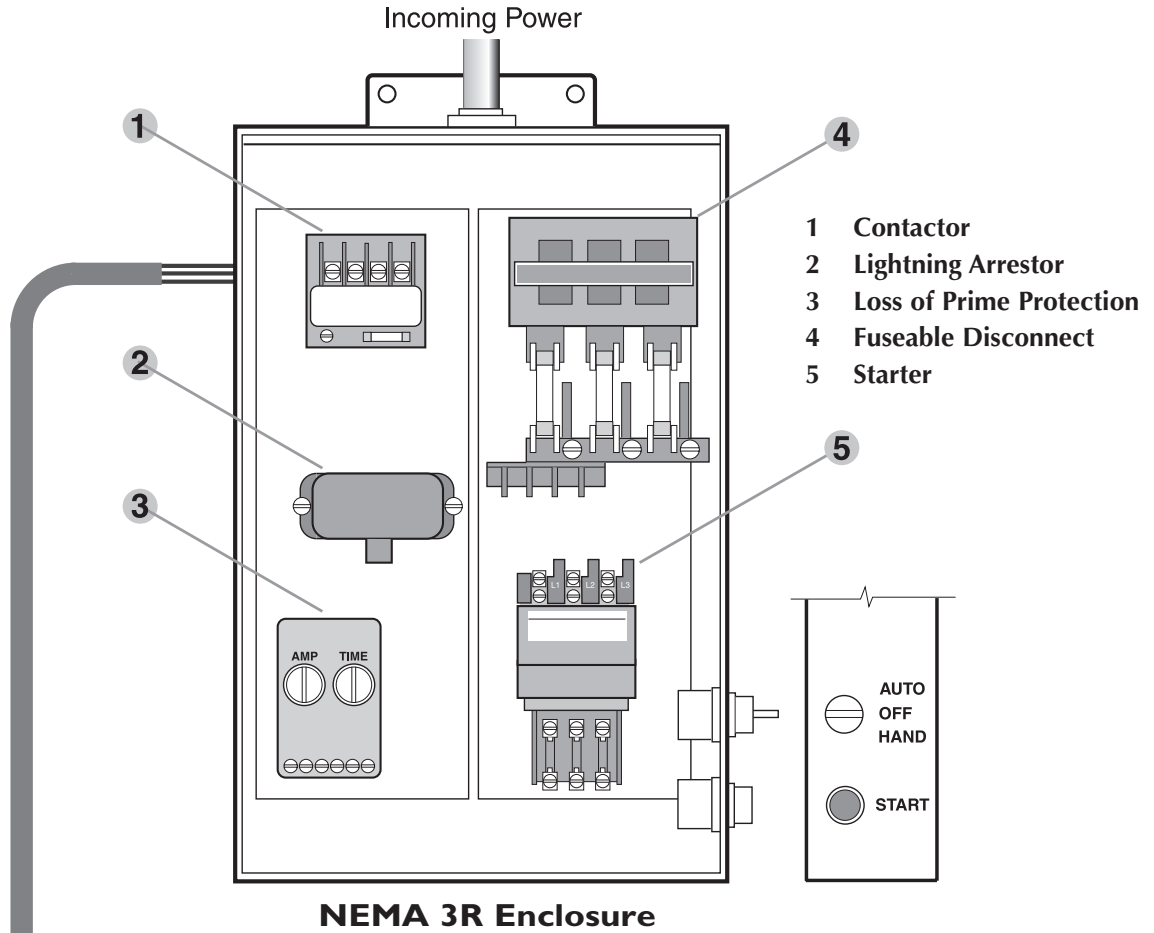

Minimum recommended components to protect your pump during operation. Check all local electrical codes prior to installation.

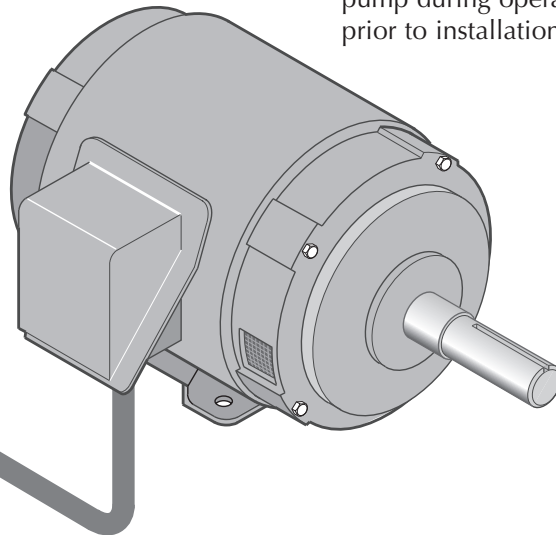

Before Start-Up

Check Rotation:

Before pump is put into operation, rotational direction must be checked to assure proper performance of pump. Refer to illustration shown below.

⚠ WARNING Risk of electric shock. Can shock, burn or kill. Disconnect power to pump before servicing. Do not attempt any wiring changes without first disconnecting power to pump.

- **Single Phase Motors:** Refer to wiring information on the motor plate to obtain proper rotation.
- **Three Phase Motors:** If pump runs backwards, reverse any two leads coming off incoming power (L1, L2, L3) until proper rotation is obtained. Reverse L1 and L2, or L2 and L3, or L1 and L3.
- **Pump running backward** - Centrifugal pumps will still pump liquids, however, GPM and head (discharge pressure) will be a fraction of the published performance.

Priming The Pump

A self priming pump only needs to be manually primed at the first start-up. Once primed, under normal conditions the pump will reprime automatically at each subsequent start-up.

To prime, remove plug from top of pump case and fill case with water. Replace plug and start pump. Unit is equipped with a flapper type check valve which will open at start-up and allow pump to evacuate air from the suction line. After several minutes of operation, pump will be fully primed and pumping water. Priming time will vary depending on length and diameter of suction line.

Starting:

⚠ CAUTION Risk of burns. Never run pump dry. Running pump without water will overheat pump and damage internal parts. Always make sure pump is primed prior to start-up.

NOTICE Refer to maintenance section if pump has packing for adjustment prior to start-up.

At initial start, prime pump as described in *Priming The Pump*. Turn on power to pump. Slowly open discharge valve until desired flow rate is achieved. Place the "Hand-Off-Auto" selector switch in the "Auto" position. The pump will be started automatically when the pilot device signals the motor starter.

Stopping:

Pump will stop automatically when the pilot device de-energizes the motor starter. Turn the "Hand-Off-Auto" selector switch to "Off" position if you want to stop the pump while it is running.

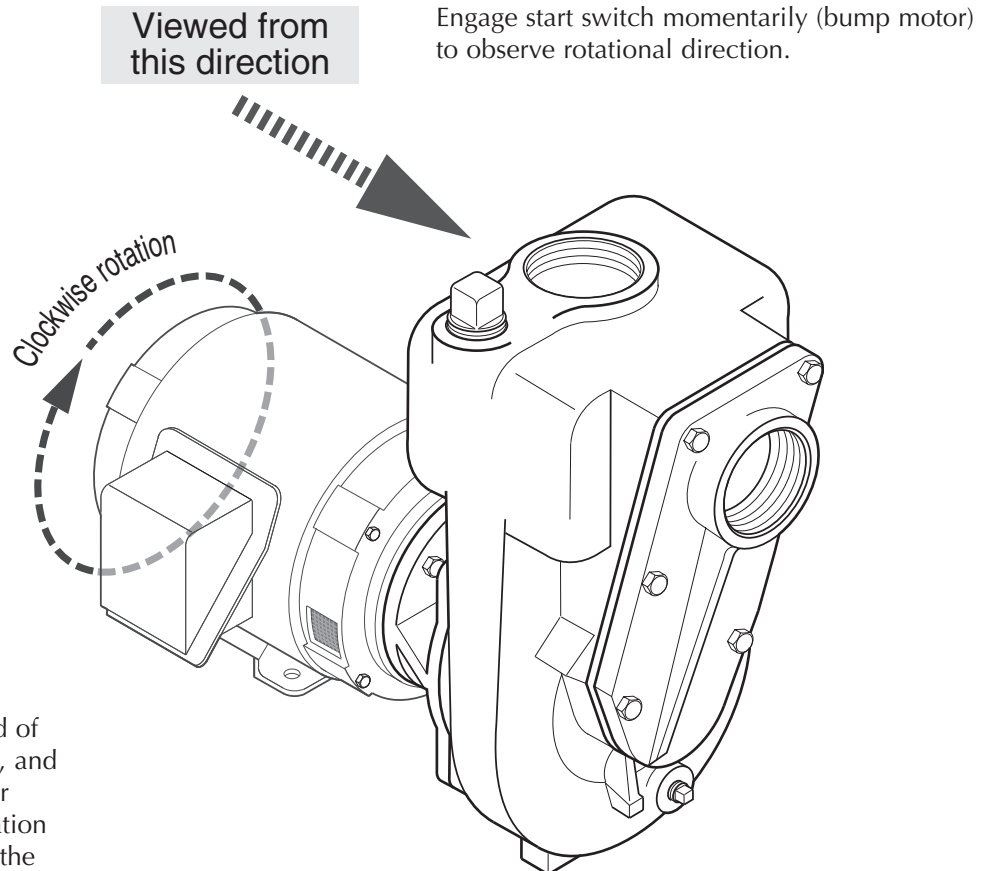

Direction of pump rotation is determined by viewing liquid end of pump from the back or shaft side, and not from looking into the impeller eye or front of volute case. A rotation direction arrow may be cast into the pump body and shows correct rotation.

Operation

NOTICE Do not start or run pump dry or damage to the mechanical seal will result.

- Wear safety glasses at all times when working on pumps.
- Do not allow pump or any system component to freeze. To do so will void warranty.
- Periodically inspect pump and system components.

Priming The Pump

A self priming pump only needs to be manually primed at the first start-up. Once primed, under normal conditions the pump will reprime automatically at each subsequent start-up.

Maintenance

Lubrication

LIQUID END of pump requires no lubrication.

MOTOR bearings are lubricated at the factory.

Re-lubrication at intervals consistent with the amount of use will provide maximum bearing life. Refer to motor Instruction Manual for proper motor lubrication and maintenance instructions.

Performance Check

Periodically check the output of the pump. If performance is noticeably reduced, refer to *Troubleshooting*.

Observational Maintenance:

When the pump and system operation have been stabilized, verify that pump unit is operating properly. Observe the following:

Vibration: All rotating machines can be expected to produce some vibration. However, excessive vibration can reduce the life of the unit. If the vibration seems excessive, discontinue operation, determine cause of the excessive vibration, and correct.

Noise: When the unit is operating under load, listen closely for unusual sounds that might indicate that the unit is in distress. Determine the cause and correct.

Operating Temperature: During operation, heat is dissipated from the pump and the driver. After a short period of time, the surface of the pump bracket will be quite warm (as high as 150°F), which is normal. If the surface temperature of the pump bracket or driver is excessive, discontinue operation, determine cause of the excessive temperature rise, and correct. Bearings will run hotter for a brief run-in period after packing, which is normal. However, worn bearings will cause excessive temperatures and need to be replaced. The pump unit is cooled by the water flowing through it, and will normally be at the temperature of the water being pumped.

Mechanical Seal: Adjustment or maintenance is normally not required. The seal is enclosed within the pump and is self adjusting. Seal is cooled and lubricated by the liquid being pumped. Refer to pages 15 and 16 for seal removal and replacement. Do not run pump dry!

Pump Protection-Cold Weather/ Wet Weather Installations:

System Drains: Provide drain valves to empty system, including pump case, to prevent freezing damage.

Shelter: If possible, provide shelter for unit to protect from weather. Allow adequate space around pump unit for service. When effectively sheltered, a small amount of heat will keep temperature above freezing. Provide adequate ventilation for unit when running. For severe weather problems, where other shelter is not practical, a totally enclosed fan-cooled enclosure can be considered for electric motors.

Condensation: When the temperature of metal parts is below dew point and the surrounding air is moist, water will condense on the metal surfaces and can cause corrosion damage. In severe situations, a space heater can be considered to warm the unit.

Mechanical Shaft Seal

Removal

Procedure and parts will vary slightly depending on pump style.

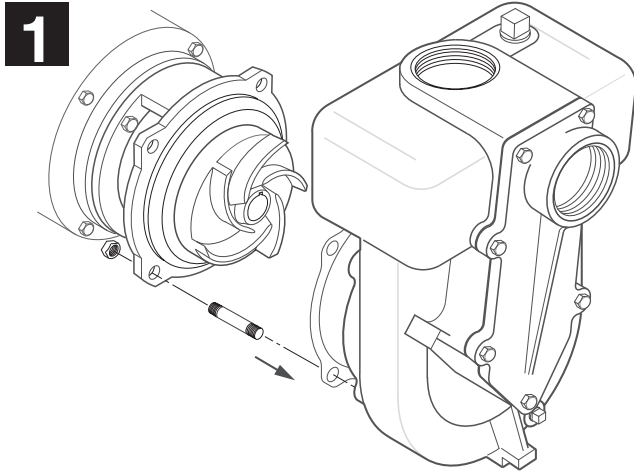

- Unfasten hardware holding volute to bracket.
- Remove volute to expose impeller.
- Peel off old gasket or O-Ring and discard.

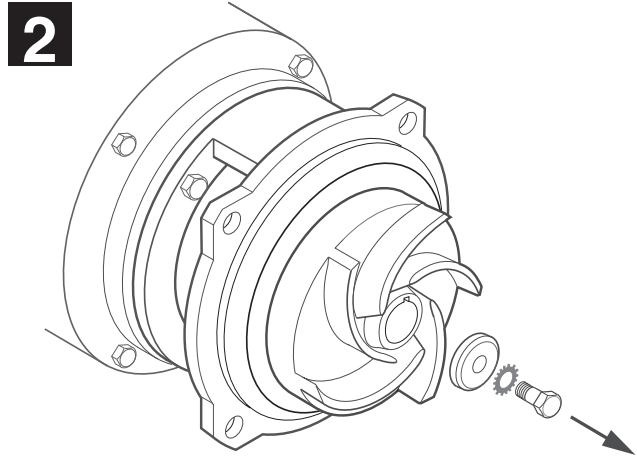

- Hold impeller stationary and remove impeller screw and associated hardware.

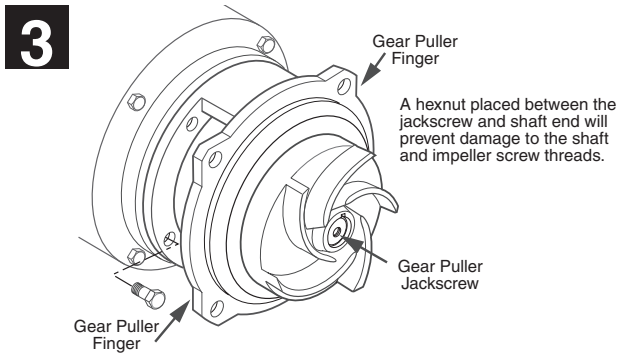

- Remove capscrews holding bracket to motor.
- Install a standard gear puller to shaft end and motor bracket placing puller fingers in the area shown.

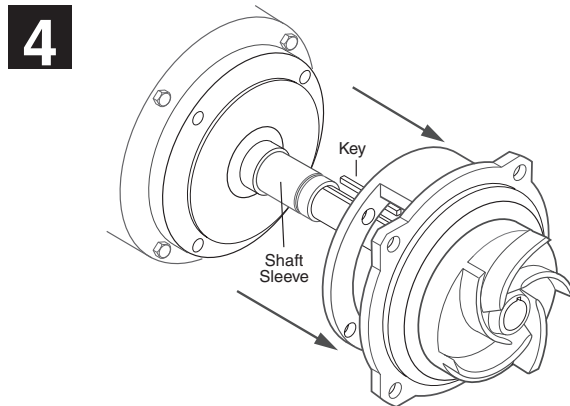

- Rotate gear puller jackscrew until impeller clears shaft. Mechanical shaft seal will come off with motor bracket.
- If a seal retaining ring is part of the assembly, it will need to be replaced.

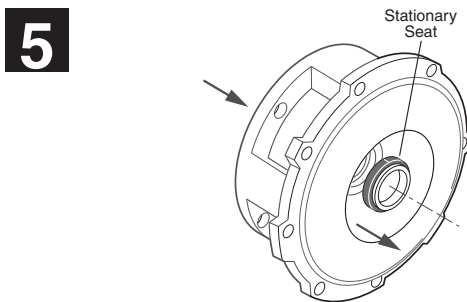

- Push stationary seal out of seal cavity from the back of bracket.
- Clean seal cavity in bracket thoroughly.

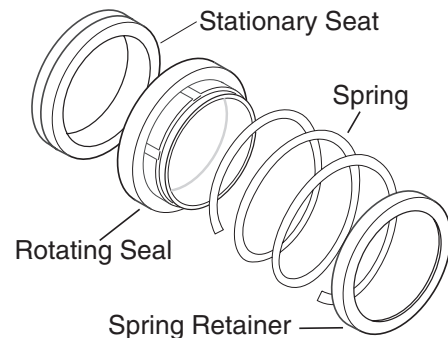

Installation

Procedure and parts will vary slightly depending on pump style.

NOTICE Do not scratch or chip polished ceramic face. Also . . .do not touch polished surface.

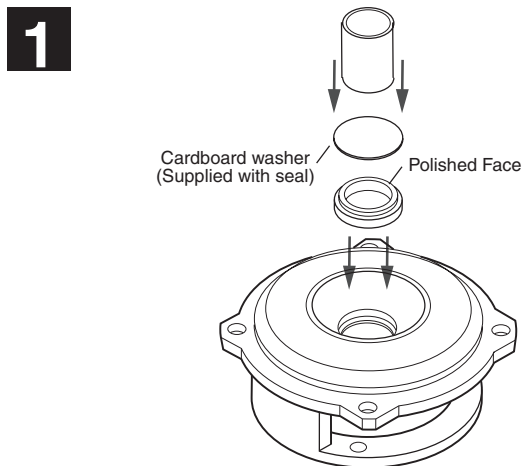

- Place bracket on a smooth, flat surface, pump side up.
- Apply a small amount of mineral oil to O-Ring on stationary seal and press into seal cavity. Cover

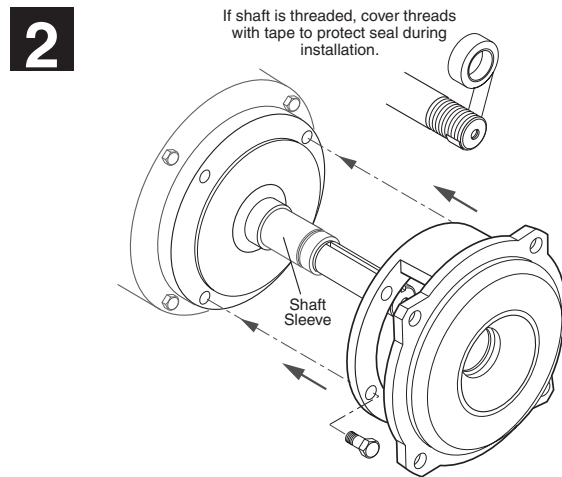

- ceramic face with cardboard washer and press straight in using a piece of pipe or tubing.
- Reinstall bracket on motor using extreme care not to scratch or chip ceramic face of seal with shaft.

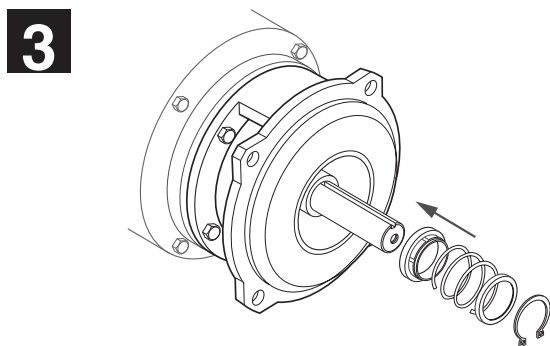

- Apply a small amount of mineral oil to inside diameter of rubber ring in rotating seat and outside of shaft sleeve. Slide rotating seat onto shaft, polished face first, until it is tight against ceramic face.
- Compress seal spring and install retaining ring in shaft sleeve groove (if used).

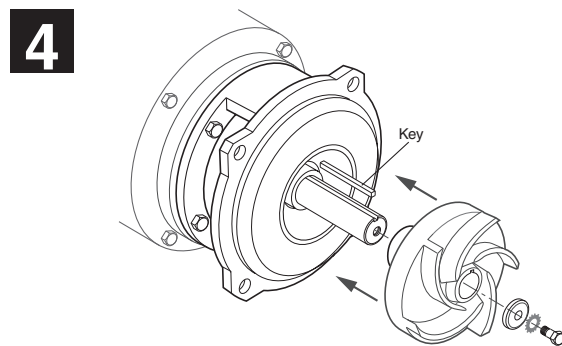

- Place impeller key in motor shaft keyway. Slide impeller on to shaft as far as possible.
- Clean threads thoroughly.
- Apply non-permanent thread adhesive to impeller capscrew and shaft threads.
- Install impeller washer, shakeproof lockwasher, and capscrew.

- Install gasket and volute on bracket. Use a new gasket or O-Ring when reassembling to prevent leakage (a coat of grease on gasket will aid in future disassembly and maintenance).
- Apply anti-seizing compound to capscrews and tighten securely.

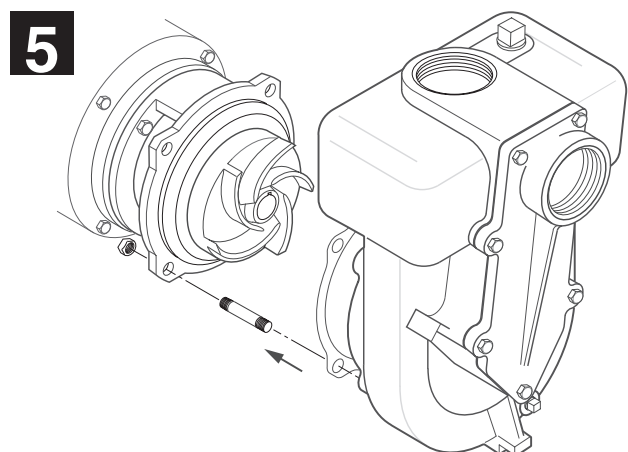

Ordering Replacement Parts:

Locate the Berkeley nameplate on pump. This plate is normally on the pump case or bracket (seal plate). A typical nameplate is shown here.

To be sure of receiving correct parts, provide all nameplate data when ordering. B.M. (Bill of Material) number is most important.

Write the nameplate information below, as nameplates can become worn or lost.

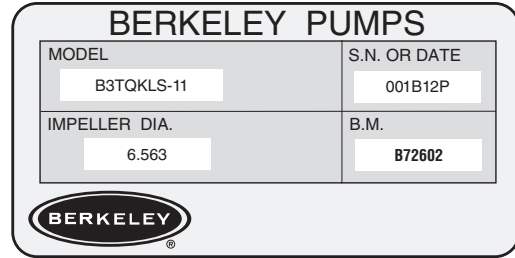

Example nameplate

Model: _____

S.N. or Date: _____

Impeller Dia.: _____

B.M. _____

Electric Motor Drive—with fixed seal plate

Mechanical Seal

- Electric motor not shown.
- Drawing shows typical motor drive pump with a mechanical shaft seal. Parts on some models will vary slightly.

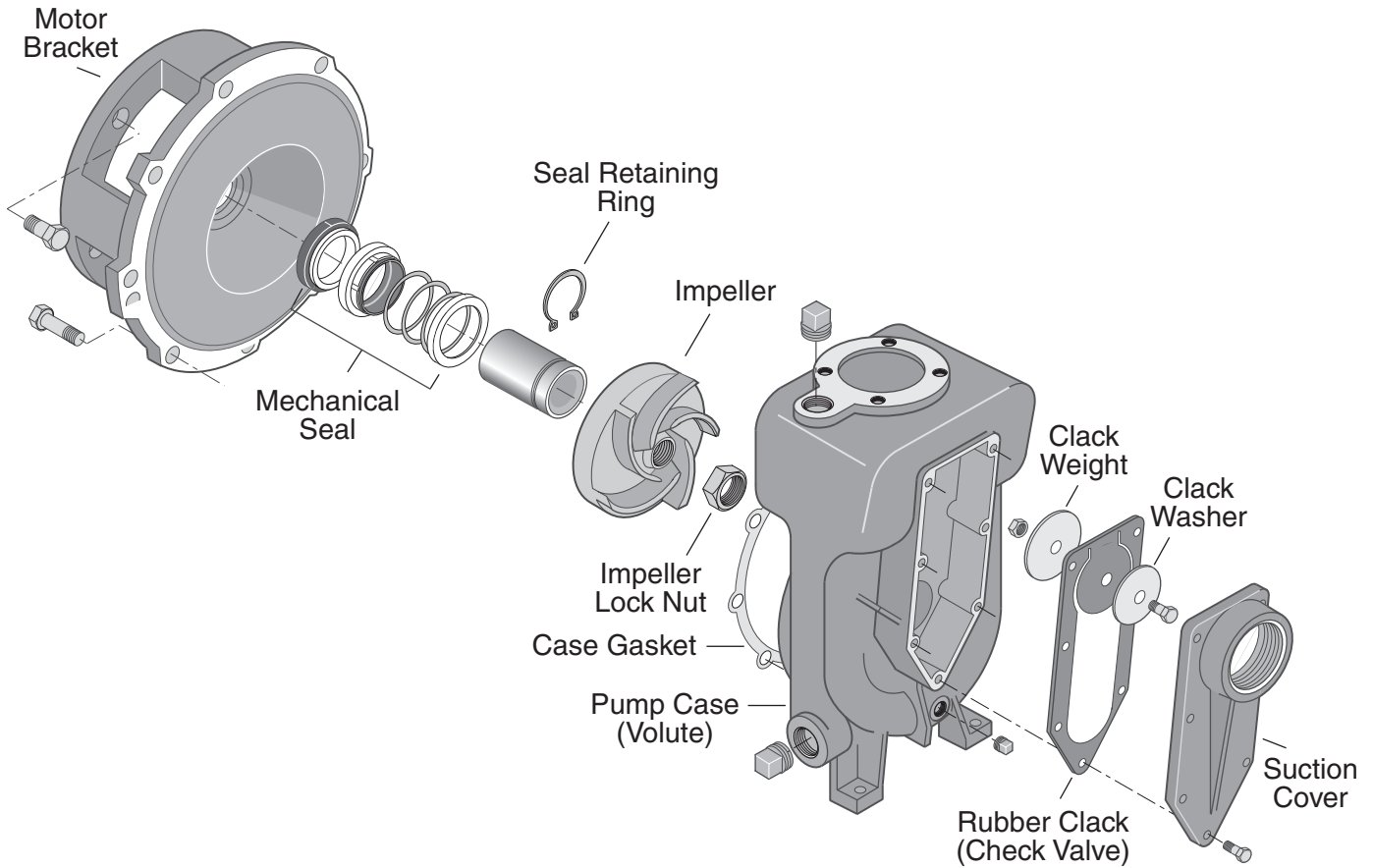

Symptom	Probable Cause																	
	Electrical									Mechanical						System		
	A	B	C	D	E	F	G	H	I	A	B	C	D	E	F	A	B	C
Pump runs, but no water delivered										X		X				X	X	
Not enough water delivered			X	X					X	X	X		X			X	X	
Not enough pressure			X	X					X	X	X		X			X	X	
Excessive vibration									X	X	X			X			X	X
Abnormal noise										X	X	X		X	X		X	X
Pump stops	X	X	X	X	X	X	X	X										
Overheating		X	X	X					X		X		X	X	X			X

Cause	Corrective Action
Electrical	
A. No voltage in power system.	Check phase-to-phase on line side of starter contactor. Check circuit breaker or fuses.
B. No voltage on one phase (Three Phase units).	Check phase voltage on line side of starter contactor. Isolate open circuit (circuit breaker, fuse, broken connections, etc.)
C. Low voltage at motor.	Running voltage across each leg of motor must be $\pm 10\%$ of nominal voltage shown on nameplate.
D. Motor leads improperly grouped for voltage.	Refer to lead grouping diagram on motor nameplate.
E. Control failure.	Check control device, starter contactor, H-O-A selector switch, etc., for malfunction.
F. Thermal overload switch open	Check phase-to-phase on line side of starter contactor.
G. Installation failure.	Check motor or windings to ground with megohmmeter.
H. Open windings.	Check leg-to-leg with ohmmeter.
I. Frequency variation.	Check frequency of power system. Must be less than 5% variation from motor nameplate rating.
Mechanical	
A. Flow through pump completely or partially obstructed.	Locate and remove obstruction. Refer to repair instructions for disassembly.
B. Wrong direction of rotation.	Reverse rotation of three phase motor by interchanging any two leads. See manufacturer's instructions for reversing single phase motor.
C. Pump lost prime.	Reprime. Inspect suction system for air leaks.
D. Internal leakage.	Check impeller for wear of controlled clearances (See Repair Instructions).
E. Loose parts	Inspect. Repair.
F. Stuffing box not properly adjusted	Adjust gland.
System	
A. Pressure required by system at design flow rate exceeds pressure rating of pump.	Compare pump pressure and flow rate against pump characteristic curve. Check for closed or partially closed valve in discharge piping system. Reduce system pressure requirement. Increase pressure capability of pump.
B. Obstruction in suction piping	Locate and remove obstruction.
C. Pressure rating of pump exceeds pressure requirement of system at design flow rate.	Compare pump pressure and flow rate against pump characteristic curve. Inspect discharge piping system for breaks, leaks, open by-pass valves, etc. If necessary, reduce flow rate by partially closing discharge valve.

