

BERKELEY® FL/FLJ Series

Cast iron, self-priming convertible jet pumps



FL Series Pumps feature a proven self-priming “convertible” design. The same convertible jet can be attached to pump for use on shallow well installation, or be utilized in 4" or larger wells for use as a double pipe deep well jet.

FL Series Pumps provide high capacities up to 11 GPM...depths to 90 feet. They are rated for 30–50 PSI operation.

APPLICATIONS

Water systems and sprinkling...for homes, farms and cottages

SPECIFICATIONS

Body and Base: Close-grained cast iron

Impeller: Lexan®

Diffuser: Reinforced polypropylene

Shaft: One-piece threaded 416 stainless steel

Pressure Switch Pre-Set: 30–50 PSI

Suction Ports: Drive-over-Suction

FEATURES

Quality Construction: Close-grained cast iron pump body and base are rugged one-piece unit, specially treated to resist corrosion. Drain port provided for easy winterizing.

Pressure Regulator: Simple, built-in regulator is performance proven. Adjustable for best performance on all deep well installations.

Lexan Impeller: Precision-molded for perfect balance...ultra-smooth for highest performance and efficiency.

Precision-Molded Diffuser: Pump primes faster, handles more air, with multi-port, precision-molded, reinforced polypropylene diffuser.

Mechanical Shaft Seal: Precision-lapped and highly polished carbon-ceramic, stainless steel construction. Internal design guarantees continuous water lubrication for maximum protection.

Motor Windings: Superior insulation materials protect against excessive moisture and contaminants...assures prolonged motor life.

Balanced Rotor: Diecast under high pressures for uniform performance and greater efficiency...dynamically balanced.

Heavy-Duty Ball Bearings: Shielded, permanently lubricated bearings, extensively tested to ensure extended life and smooth, quiet operation.

Pump and Motor Shaft: Stainless steel for maximum corrosion resistance; one-piece threaded shaft for positive impeller drive and alignment.

Dustproof Cover: Dustproof canopy protects all electrical components from dirt, dust and insects; ventilating air cannot contaminate vital switching components...eliminates the most common cause of motor failure.

ORDERING INFORMATION

CATALOG NUMBER	HP	DESCRIPTION	PIPE TAPPING SIZES			MOTOR VOLTAGE	APPROX. WT. LBS.
			SUCT.	DRIVE	DISCH.		
5FL/5FLJ*	1/2	Deep Well Jet	1-1/4"	1"	1"	115/230	44
7FL/7FLJ*	3/4	Deep Well Jet	1-1/4"	1"	1"	115/230	45

*FLJ Models include ejector package.

A Jet Package should be ordered with every FL Series Pump.

NOTE: Pumps installed with a Pro-Source® tank require a 100 PSI relief valve. Pumps installed with a conventional tank require a 75 PSI relief valve. Relief valve must be capable of relieving flow of pump at relief pressure.

Pentair trademarks and logos are owned by Pentair plc or its affiliates. All other third party registered and unregistered trademarks and logos are the property of their respective owners.

BERKELEY® FL/FLJ Series

Cast iron, self-priming convertible jet pumps

OUTLINE DIMENSIONS

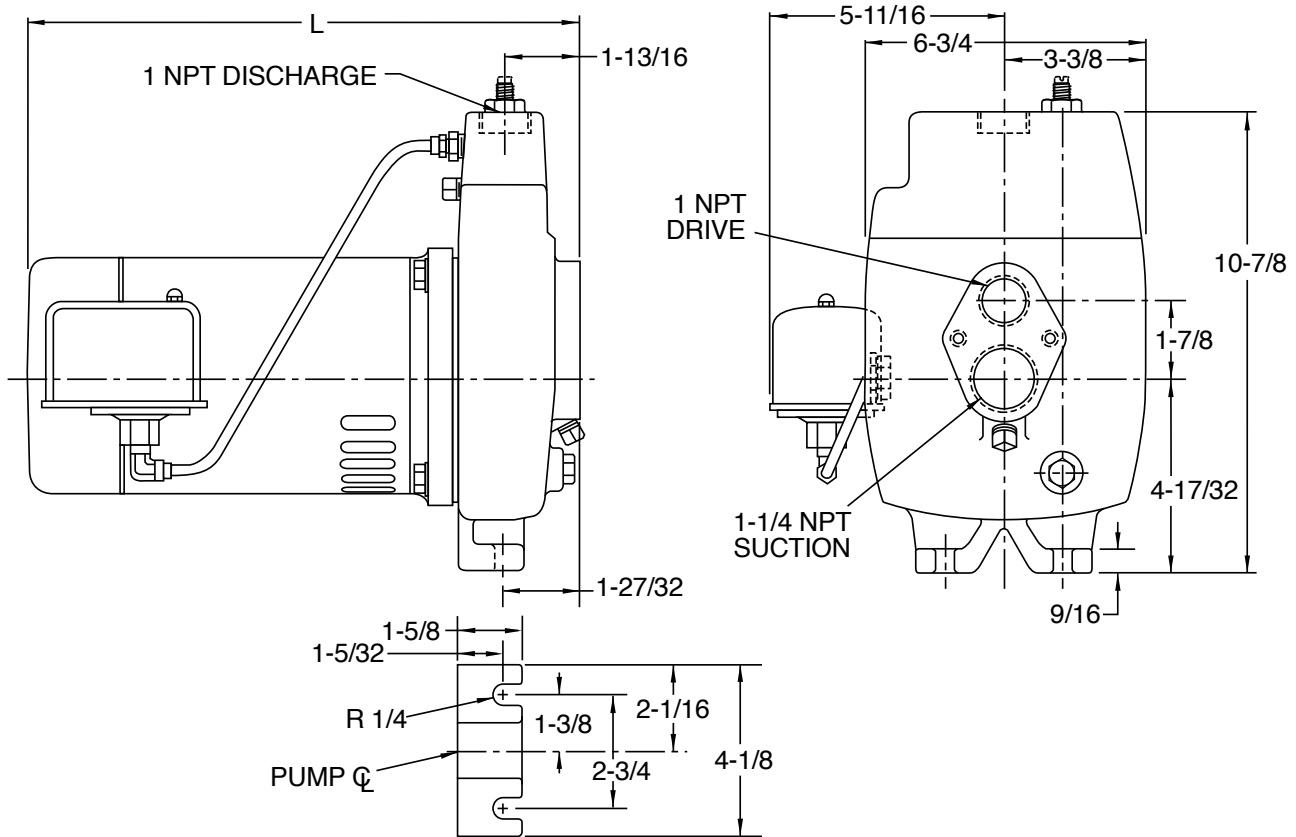

MOUNTING BRACKET DETAIL

CATALOG NUMBER	L
5FL	11-13/16
7FL	12-9/16

Dimensions (in inches) are for estimating purposes only.

PUMP PERFORMANCE - FLJ MODELS*					
Catalog Number	Ejector Package (Included)	Shallow Well		Deep Well	
		Nozzle	Venturi	Nozzle	Venturi
5FLJ	J198-26	J34P-41	N32P-66B	J34P-42	J32P-18
7FLJ	J198-27	J34P-41	N32P-66B	J34P-43	J32P-18

BERKELEY® FL/FLJ Series

Cast iron, self-priming convertible jet pumps

PUMP PERFORMANCE (Capacity in gallons per minute) SHALLOW WELL – 5', 10', 15', 20' AND 25' PUMPING DEPTHS

CAT. NO.	HP	DISCHARGE PRESSURE	PUMPING DEPTH TO WATER IN FEET														
			5 FT. LIFT			10 FT. LIFT			15 FT. LIFT			20 FT. LIFT			25 FT. LIFT		
5FL	1/2	JET PACKAGE	10SD	29SD		10SD	29SD		10SD	29SD		10SD	29SD		10SD	29SD	
		Venturi N32P-__	-67B	-66B		-67B	-66B		-67B	-66B		-67B	-66B		-67B	-66B	
		Nozzle J34P-__	-44	-41		-44	-41		-44	-41		-44	-41		-44	-41	
		20 PSI	12.0	9.1		9.7	8.4		12.0	7.3		9.7	6.2		6.7	4.7	
		30 PSI	10.8	9.0		9.5	8.3		10.8	7.2		9.5	6.1		6.7	4.7	
		40 PSI	5.2	7.9		4.2	7.2		5.2	6.3		4.2	5.4		2.5	4.1	
		50 PSI		4.1			3.8			3.3			2.8			2.1	
		60 PSI															
		Shut-off-PSI	53	61		51	58		49	56		47	54		45	52	
7FL	3/4	JET PACKAGE	11SD	10SD	29SD	11SD	10SD	29SD	11SD	10SD	29SD	11SD	10SD	29SD	11SD	10SD	29SD
		Venturi N32P-__	-68B	-67B	-66B	-68B	-67B	-66B	-68B	-67B	-66B	-68B	-67B	-66B	-68B	-67B	-66B
		Nozzle J43P-__	-44	-44	-41	-44	-44	-41	-44	-44	-41	-44	-44	-41	-44	-44	-41
		20 PSI	20.6	14.4	10.1	19.0	13.2	9.3	16.5	11.5	8.1	13.3	9.5	6.9	9.8	6.9	5.3
		30 PSI	19.6	14.3	9.9	18.1	13.1	9.1	15.7	11.4	7.9	13.3	9.5	6.7	9.8	6.9	5.1
		40 PSI	10.3	12.1	9.8	9.4	11.2	9.0	8.2	9.7	7.8	6.4	8.3	6.6	3.1	6.3	5.1
		50 PSI		4.6	7.3		4.3	6.7		3.7	5.8		2.6	4.9		1.0	3.8
		60 PSI			3.5			3.2			2.8			2.4			
		Shut-off-PSI	55	59	70	53	57	66	50	55	64	48	53	61	46	51	59

NOTE: Pumps are supplied with 30-50 pressure switch setting. Cut-in pressure settings are adjustable.

PUMP PERFORMANCE (Capacity in gallons per minute) DEEP WELL (40 PSI) 4" DOUBLE PIPE

CAT. NO.	HP	JET NO.	USES VENTURI	USES NOZZLE	PUMPING DEPTH IN FEET									MAX. PUMP SHUT-OFF PRESSURE PSI	
					20'	30'	40'	50'	60'	70'	80'	90'	JET AT 20 FT. DEPTH	JET AT MAX. DEPTH	
5FL	1/2	4SD	J32P-24	J34P-41	5.9	4.5	3.4	2.3						68	54
		15SD	J32P-18	J34P-42	4.6	3.9	3.3	2.8	2.3	1.7				84	59
7FL	3/4	54SD	J32P-22	J34P-44	8.0	6.9	5.7	4.8	3.8	3.2				94	70
		55SD	J32P-18	J34P-43	5.0	4.3	3.7	3.2	2.6	2.2	1.8	1.5		96	63

DEEP WELL (40 PSI) 2" SINGLE PIPE

5FL	1/2	8AP	J32P-18	J34P-42	4.7	4.1	3.4	2.5	1.9	1.5			84	58
7FL	3/4	54AP	J32P-22	J34P-44	7.4	6.3	5.2	3.9	2.5	2.0			82	54

DEEP WELL (40 PSI) 3" SINGLE PIPE

5FL	1/2	19CP	J32P-24	J34P-41	5.9	4.5	3.4	2.3					68	54
		16CP	J32P-18	J34P-42	4.6	3.9	3.3	2.8	2.3	1.7			84	59
7FL	3/4	9CP	J32P-26	J34P-41	9.4	8.0	6.6						77	68
		54CP	J32P-22	J34P-44	8.0	6.9	5.7	4.8	3.8	3.2			94	70

Tested and rated in accordance with Water Systems Council Standards.

NOTE: Pumps installed with a Pro-Source® tank require a 100 PSI relief valve. Pumps installed with a conventional tank require a 75 PSI relief valve. Relief valve must be capable of relieving entire flow of pump at relief pressure.



US: 293 WRIGHT STREET, DELAVAN, WI 53115 WWW.BERKELEYPUMPS.COM PH: 888-782-7483 ORDERS FAX: 800-426-9446
CANADA: 490 PINEBUSH ROAD, UNIT 4, CAMBRIDGE, ONTARIO N1T 0A5 PH: 800-363-7867 ORDERS FAX: 888-606-5484
Because we are continuously improving our products and services, Pentair reserves the right to change specifications without prior notice.