

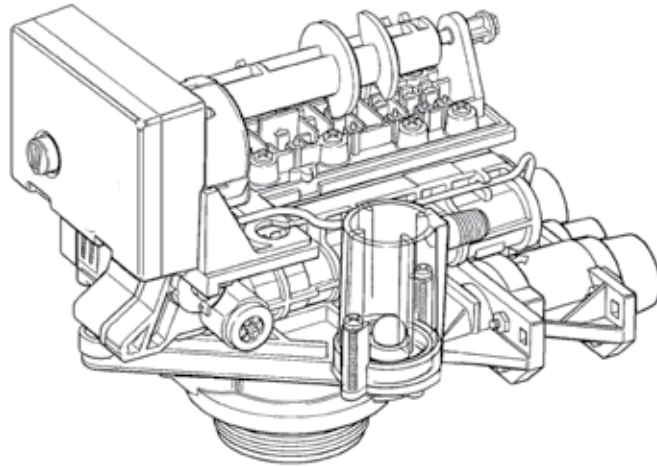

**AUTOTROL®** 255 VALVE/400 SERIES CONTROLS  
SERVICE MANUAL



## TABLE OF CONTENTS

MANUAL OVERVIEW .....	2
SAFETY INFORMATION .....	2
SYSTEM SPECIFICATIONS .....	2
EQUIPMENT INSTALLATION.....	4
SYSTEM STARTUP.....	6
PROGRAMMING .....	6
SERVICE AND MAINTENANCE.....	9
255 VALVE & TANK ADAPTER MODULE .....	10
255 SERIES .....	12
TROUBLESHOOTING .....	14
FLOW DIAGRAMS.....	16
FLOW DATA CHARTS.....	17

## MANUAL OVERVIEW

### How To Use This Manual

This installation manual is designed to guide the installer through the process of installing and starting conditioners featuring the 400 series controllers.

This manual is a reference and will not include every system installation situation. The person installing this equipment should have:

- Training in the 400 series controllers and water conditioner installation
- Knowledge of water conditioning and how to determine proper control settings
- Basic plumbing skills
- The directional instructions "left" and "right" are determined by looking at the front of the unit.

## SAFETY INFORMATION

### Electrical

There are no user-serviceable parts in the AC adapter, motor, or controller. In the event of a failure, these should be replaced:

- All electrical connections must be completed according to local codes.
- Use only the power AC adapter that is supplied.
- The power outlet must be grounded.
- To disconnect power, unplug the AC adapter from its power source.

### Mechanical

- Do not use petroleum based lubricants such as petroleum jelly, oils, or hydrocarbon based lubricants. Use only 100% silicone lubricants.
- All plastic connections should be hand tightened. Plumber's tape may be used on connections that do not use an O-ring seal. **Do not use pliers or pipe wrenches.**
- All plumbing must be completed according to local codes.
- Soldering near the drain line should be done before connecting the drain line to the valve. Excessive heat will cause interior damage to the valve.
- Do not use lead-based solder for sweat solder connections.

- The drain line must be a minimum of 1/2" diameter. Use 3/4" pipe if the backwash flow rate is greater than 5 GPM (18.9 Lpm) or the pipe length is greater than 20 feet (6 m).
- Do not support the weight of the system on the control valve fittings, plumbing, or the bypass.

### General

- Keep the media tank in the upright position. Do not turn on side, upside down, or drop. Turning the tank upside down will cause media to enter the valve.
- Operating ambient temperature is between 34°F (1°C) and 120°F (49°C).
- Operating water temperature is between 34°F (1°F) and 100°F (38°C).
- Working water pressure range is 20 to 125 psi (1.38 to 8.61 bar). In Canada the acceptable working water pressure range is 20 to 100 psi (1.38 to 6.89 bar).
- Use only regenerant salts designed for water softening. Do not use ice melting, block, or rock salts.
- Follow state and local codes for water testing. Do not use water that is micro-biologically unsafe or of unknown quality.
- When filling media tank, do not open water valve completely. Fill tank slowly to prevent media from exiting the tank.
- When installing the water connection (bypass or manifold) connect to the plumbing system first. Allow heated parts to cool and cemented parts to set before installing any plastic parts. Do not get primer or solvent on O-rings, nuts, or the valve.

## CALIFORNIA PROPOSITION 65 WARNING

**⚠ WARNING:** This product contains chemicals known to the State of California to cause cancer or birth defects or other reproductive harm.

## SYSTEM SPECIFICATIONS



The systems below have been tested and certified by the WQA to NSF/ANSI Std. 44 and NSF/ANSI 372 for "lead free" compliance.

The 255 valve has been tested and certified by the WQA to NSF/ANSI Std. 61 Section 8 Mechanical Devices

WQA Certified 255-460i Systems:

255-460i-075-844

255-460i-100-948

Working Pressure:	20-125 psi (1.38 - 8.61 bar)
Standard 12 Volt Transformer Input Electrical Rating:	115V 60 Hz
Optional 12 Volt Transformer Input Electrical Rating:	115V 50 Hz, 230V 50 Hz, 230V 60 Hz, 100V 60 Hz, 100V 50 Hz
Operating Ambient Temperature:	34-120°F (1-49°C)
Operating Water Temperature:	34-100°F (1-38°C)

For service or parts, please contact your local professional water treatment dealer.

**WATER SOFTENER PERFORMANCE DATA SHEET**

<b>Model</b>	<b>255-460i-075-844</b>	<b>255-460i-100-948</b>	
Rated Service Flow (gpm)	6.0	10.0	
Pressure Drop at Rated Service Flow Rate (psi)	9.0	15.0	
Rated Capacity (grains @ lb. of salt)	15,362 @ 3.75 21,197 @ 7.5 23,148 @ 10.5	20,483 @ 5.0 28,263 @ 10.0 30,865 @ 14.0	
Rated Efficiency (grains/lb Salt @ lb. of salt)	4,096/lb. salt @ 3.75	4,096/lb. salt @ 5.0	
Maximum Flow Rate During Regeneration (gpm)	1.7	2.1	
Sybron C-249NS Ion Exchange Resin (cu. ft)	0.75	1.0	
Backwash - GPM	1.7	2.1	
Fast Rinse/Purge - GPM	1.7	2.1	
<p>Operating Pressure: 20 - 125 psi or 1.4 - 8.8 kg/Centimeter<sup>2</sup>. Operating Temperature: 34 - 100° F or 1.1 - 38° C                  Acceptable Salt Type: Sodium Chloride - Pellet or solar salt for water softeners                  All Systems above tested at 35psi +/- 5 psi, pH of 7.5 +/- 0.5, Capacity Testing Flow Rate = 50% of the rated service flow rate for the various size systems.</p>			

These water softener systems have been tested by WQA and conform to NSF/ANSI 44 for specific performance claims as verified and substantiated by test data. The rated salt efficiencies above were also determined in accordance with NSF/ANSI 44 and are only valid at the salt dosage referenced above. An efficiency rated water softener is a demand initiated regeneration (DIR) softener which also complies with specific performance specifications intended to minimize the amount of regenerant brine and water used in its operation. Efficiency rated water softeners shall have a rated salt efficiency of not less than 3350 grains of total hardness exchanged per pound of salt (based on NaCl equivalency) (477 grams of total hardness exchanged per kilogram of salt), and shall not deliver more salt than its listed rating. The rated efficiency of the water softener, the salt dosage at that efficiency, the capacity at that salt dosage and that of the efficiency is only valid at the stated salt dosage. Efficiency is measured by a laboratory test described in NSF/ANSI 44. The test represents the maximum possible efficiency the system can achieve. Operational efficiency is the actual efficiency achieved after the system has been installed. It is typically less than the efficiency due to individual application factors including water hardness, water usage, and other contaminants that reduce the water softener's capacity. These systems are not intended to be used for treating water that is microbiologically unsafe or of unknown quality without adequate disinfection before or after the system. Refer to the system Installation and Service Manuals for set-up and programming instructions. Contact your local Autotrol dealer for parts and service. See your owner's manual for warranty information.

**Important Notice:** For conditions of use, health claims certified by the California Department of Public Health and replacement parts, see product data sheet

**lowa Requirement:**



**Tested and Certified by WQA against NSF/ANSI Standard 44 & NSF/ANSI 372 for "lead free" compliance.**

The valve used on this unit is Tested and Certified by WQA to NSF/ANSI Std. 61 Section 8 for Material Safety Only

Seller: \_\_\_\_\_ Date: \_\_\_\_\_  
 Buyer: \_\_\_\_\_ Date: \_\_\_\_\_

**PENTAIR Residential Filtration, LLC**  
**5730 North Glen Park Road Milwaukee, Wisconsin 53209**  
**PHONE: (262)-238-4400**

## EQUIPMENT INSTALLATION

### Autotrol 255 Valve Control Module Features

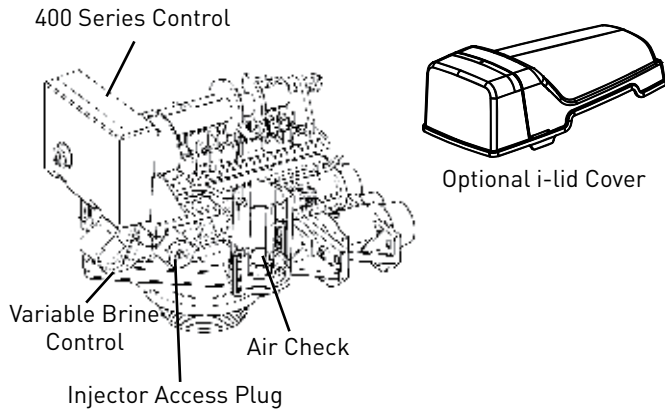

Figure 1

### Tank Adapter Module Features

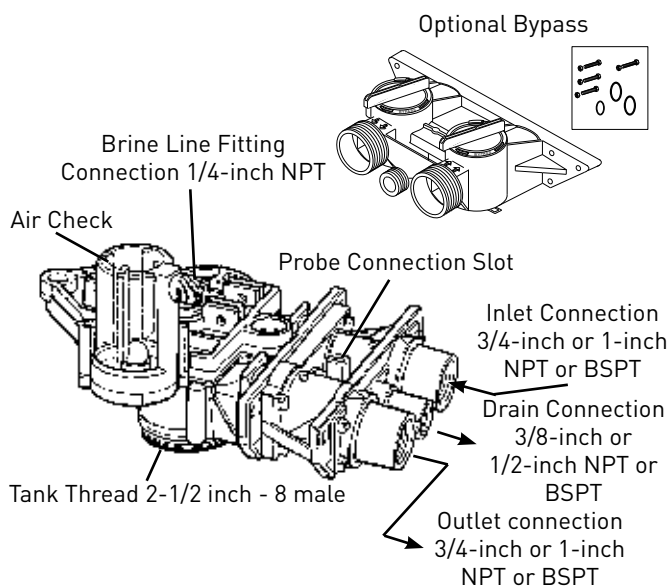

Figure 2

### System Regeneration Cycles

#### 1. Service (Downflow):

Untreated water is directed down through the resin bed and up through the riser tube. The hardness ions attach themselves to the resin and are removed from the water. The water is conditioned as it passes through the resin bed.

#### 2. Backwash (Upflow):

The flow of water is reversed by the control valve and directed down the riser tube and up through the resin bed. During the backwash cycle, the bed is expanded and debris is flushed to the drain.

#### 3. Brine/Slow Rinse (Downflow):

The control directs water through the brine injector and brine is drawn from the regenerant tank. The brine is then directed down through the resin bed and up through the riser tube to the drain. The hardness ions are displaced by sodium ions and are sent to the drain. The resin is regenerated during the brine cycle. Brine draw is completed when the air check closes.

#### 4. Fast Rinse (Downflow):

The control directs water down through the resin bed and up through the riser tube to the drain. Any remaining brine residual is rinsed from the resin bed.

#### 5. Brine Refill (Downflow):

Brine refill occurs during a portion of the fast rinse cycle. Water is directed to the regenerant tank at a controlled rate, to create brine for the next regeneration.

#### 6. Repressurize Cycle — (No Flapper Open):

This cycle closes all flappers for a short time to allow the air and water to hydraulically balance in the valve before continuing the regeneration.

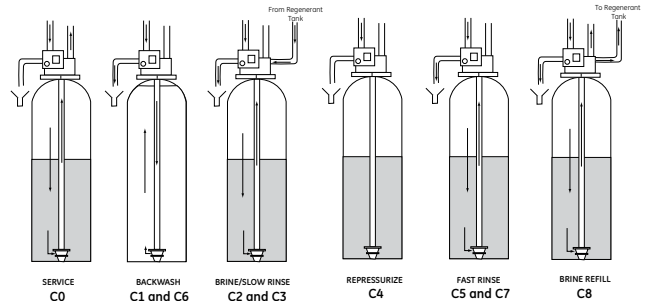

Figure 3

**NOTE: All plumbing must conform to local codes.** Inspect unit carefully for carrier shortage or shipping damage.

### Location Selection

1. The distance between the unit and a drain should be as short as possible.
2. If it is likely that supplementary water treating equipment will be required, make certain adequate additional space is available.
3. Since salt must be added periodically to the brine tank, the location should be easily accessible.
4. Do not install any unit closer to a water heater than a total run of 10 feet (3 m) of piping between the outlet of the conditioner and the inlet to the heater. Water heaters can sometimes overheat to the extent they will transmit heat back down the cold pipe into the unit control valve. Hot water can severely damage the conditioner. A 10 foot (3-m) total pipe run, including bends, elbows, etc., is a reasonable distance to help prevent this possibility. A positive way to prevent hot water from flowing from heat source to the conditioner, in the event of a negative pressure situation, is to install a check valve in the soft water piping from the conditioner. If a check valve is installed, make certain the water heating unit is equipped with a properly rated temperature and pressure safety relief valve. Also, be certain that local codes are not violated.
5. Do not locate unit where it or its connections (including the drain and overflow lines) will ever be subjected to room temperatures under 34°F (1°C) or over 120°F (49°C).
6. Do not install unit near acid or acid fumes.
7. The use of resin cleaners in an unvented enclosure is not recommended.

## EQUIPMENT INSTALLATION *CONTINUED*

### Water Line Connection

The installation of a bypass valve system is recommended to provide for occasions when the water conditioner must be bypassed for hard water or for servicing.

The most common bypass systems are the Autotrol® Series 256 bypass valve (Figure 4) and plumbed-in globe valves (Figure 5). Though both are similar in function, the 256 Autotrol bypass offers simplicity and ease of operation.

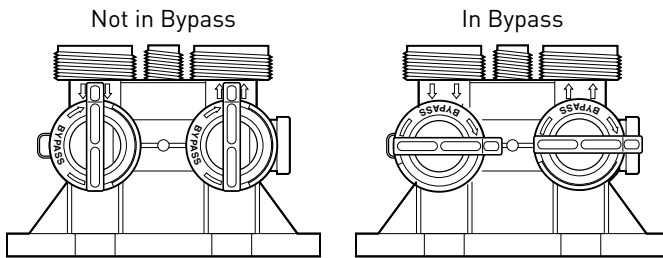

Figure 4 Autotrol Series 256 Bypass Valve

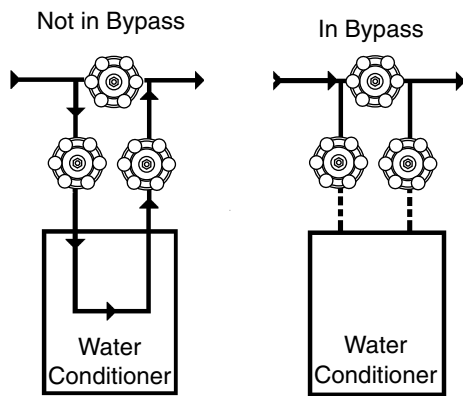

Figure 5 Typical Globe Valve Bypass System

### Drain Line Connection

1. Ideally located, the unit will be above and not more than 20 feet (6.1 m) from the drain. For such installations, use an appropriate adapter fitting (not supplied), to connect 1/2 inch (1.3 cm) plastic tubing to the drain line connection of the control valve.
2. If the unit is located more than 20 feet (6.1 m) from drain, use 3/4 inch (1.9 cm) tubing for runs up to 40 feet (12.2 m). Also, purchase appropriate fitting to connect the 3/4 inch tubing to the 1/2 inch NPT drain connection.
3. If the unit is located where the drain line must be elevated, you may elevate the line up to 6 feet (1.8 m) providing the run does not exceed 15 feet (4.6 m) and water pressure at conditioner is not less than 40 psi (2.76 bar). You may elevate an additional 2 feet (61 cm) for each additional 10 psi (0.69 bar).
4. Where the drain line is elevated but empties into a drain below the level of the control valve, form a 7-inch (18 cm) loop at the far end of the line so that the bottom of the loop is level with the drain line connection. This will provide an adequate siphon trap.
5. Where the drain empties into an overhead sewer line, a sink-type trap must be used.

**IMPORTANT:** Never insert drain line into a drain, sewer line or trap. Always allow an air gap between the drain line and the wastewater to prevent the possibility of sewage being back-siphoned into conditioner.

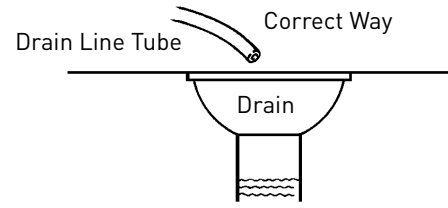

Figure 6

**NOTE:** Standard commercial practices have been expressed here. Local codes may require changes to these suggestions.

### Brine Line Connection

It will be necessary to install the brine tube and line to a fitting installed on the air check. Apply plumber tape on all threaded connections.

Be sure all fittings and connections are tight so that premature checking does not take place. Premature checking is when the ball in the air check falls to the bottom before all brine is drawn out of the brine tank. See Placing Conditioner into Operation section.

### Overflow Line Connection

In the absence of a safety overflow and in the event of a malfunction, the BRINE TANK OVERFLOW will direct "overflow" to the drain instead of spilling on the floor where it could cause considerable damage. This fitting should be on the side of the cabinet or brine tank.

To connect overflow, locate hole on side of brine tank. Insert overflow fitting (not supplied) into tank and tighten with plastic thumb nut and gasket as shown (Figure 7). Attach length of 1/2 inch (1.3 cm) I.D. tubing (not supplied) to fitting and run to drain. Do not elevate overflow line higher than 3 inches (7.6 cm) below bottom of overflow fitting. Do not tie into drain line of control unit. Overflow line must be a direct, separate line from overflow fitting to drain, sewer or tub. Allow an air gap as per drain line instructions (Figure 6).

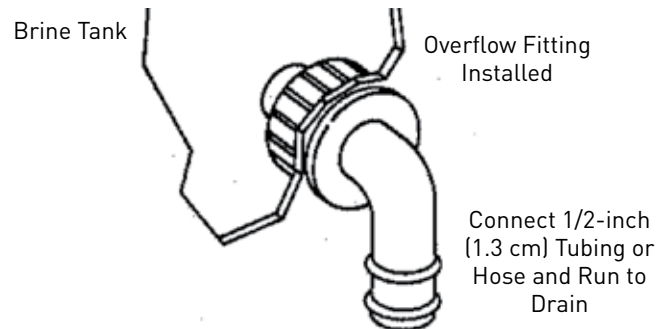

Figure 7

### Low Voltage Transformer

Use only the included transformer for powering the 400 series timers. Connect the plug of the transformer secondary cable to the mating socket on the control (see Figure 8).

Be certain that the transformer is plugged into a correct voltage source that is not controlled by a wall switch.

## EQUIPMENT INSTALLATION *CONTINUED*

### Increasing the Length of the Transformer Cord

If it is necessary to extend the length of the transformer cord, an optional 15 foot (4.6 m) extension is available (see Figure 9).



Figure 8



## SYSTEM STARTUP

### Initial Startup

After the water conditioning system is installed, the conditioner should be disinfected before it is used to treat potable water. Refer to the Disinfection of Water Conditioners section in this manual. Complete the following steps to place the conditioner into operation:

1. Remove control valve cover.

**NOTE:** The following steps will require turning the indicator knob (Figure 11) to various positions. Insert a wide-blade screwdriver into arrow slot in indicator knob and press in firmly. With knob held in, rotate COUNTERCLOCKWISE only until arrow or knob points to desired position. Rotation is made much easier if you grasp the camshaft with your free hand and turn it at the same time. Then permit knob to spring back out.

2. Insert screwdriver into slot in indicator knob (Figure 11). Press in and rotate knob COUNTERCLOCKWISE until arrow points directly to the word BACKWASH.
3. Fill resin tank with water.
  - a. With water supply off, place the bypass valve(s) into the "NOT IN BYPASS" position.
  - b. Open water supply valve very slowly to approximately the 1/4 open position.

**IMPORTANT:** If opened too rapidly or too far, resin may be lost. In this position, you should hear air escaping slowly from the drain line.

- c. When all of the air has been purged from the tank (water begins to flow steadily from the drain), open the water supply valve all the way.
  - d. Allow water to run to drain until clear.
  - e. Turn off water supply and let the unit stand for about five minutes. This will allow all trapped air to escape from the tank.
4. Add water to brine tank (initial fill). With a bucket or hose, add approximately 4 gallons (15 liters) of water to brine tank. If the tank has a salt platform above the bottom of the tank, add water until the level is approximately 1 inch (25 mm) above the platform.

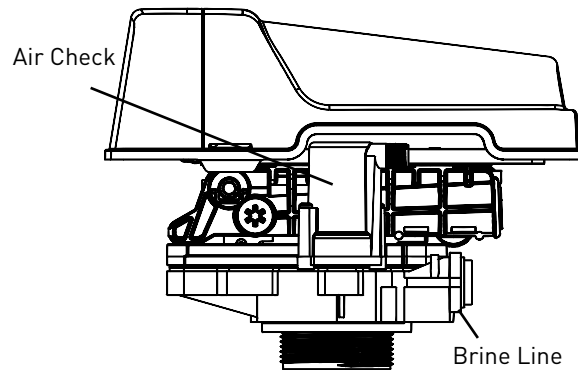

Figure 9 - Control Valve

5. Put into operation.
  - a. Open water supply valve slowly to full open position.
  - b. Carefully advance indicator knob COUNTERCLOCKWISE to center of FAST RINSE/REFILL position and hold there until air check (Figure 10) fills with water and water starts to flow through brine line into brine tank. Do not run for more than two minutes.
  - c. Advance indicator knob COUNTERCLOCKWISE until arrow points to the center of the BRINE/SLOW RINSE position.
  - d. With the conditioner in this position, check to see if water is being drawn from the brine tank. The water level in the brine tank will recede very slowly. Observe for at least three minutes. If the water level does not recede or goes up, or if air enters the transparent air check chamber and the ball falls and seats, reference Troubleshooting section.
  - e. Advance indicator knob COUNTERCLOCKWISE to CONDITIONED WATER.
  - f. Run water from a nearby faucet until the water is clear and soft.

## PROGRAMMING

### 440i Control (obsolete)

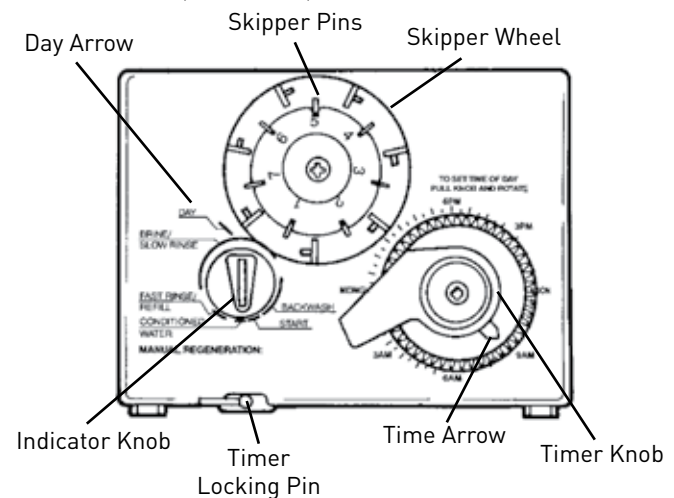

Figure 10

## PROGRAMMING *CONTINUED*

### Programming

- Set days of regeneration on skipper wheel (Figure 11).
  - Pull all skipper pins outward (away from control).
  - Rotate skipper wheel until day arrow points to current day or number 1.
  - Depress skipper pin(s) at day(s) for which regeneration is desired.
- Set the time of day.
  - Grasp timer knob and pull outward.
  - Rotate in either direction until the timer arrow points to the actual time of day.
  - Release timer knob.

**NOTE:** With the time of day properly set, the conditioner will regenerate at about 2:30 a.m. If you prefer to have the unit regenerate at an earlier or later time, simply set current time-of-day accordingly (e.g., to have the unit regenerate at 4:30 a.m.—two hours later—set the clock two hours earlier than the actual time of day.)

**NOTE:** The Timer Locking Pin should always be horizontal (Figure 11) during operation.

### 460i Control

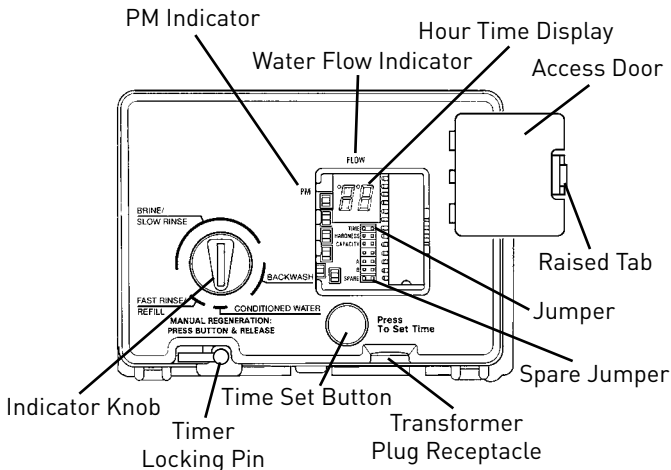

Figure 11

### Programming

Plug the wall-mount transformer into a functioning electrical outlet that is not controlled by a switch. Plug the transformer into the transformer plug receptacle on the control.

Open the access door by pushing the raised tab on the door toward the left while pulling the tab out (Figure 12).

### Time of Day Setting

With the jumper on the set of pins next to the word TIME (Figure 13), set the time of day to the closest hour by pressing the black TIME SET button. PM hours are indicated by a light next to the letters PM on the display window.

**NOTE:** The use of a small needle-nose pliers will aid in moving the jumper.

**NOTE:** The unit is factory set to regenerate at 2:00 a.m. If you prefer to have the unit regenerate at an earlier or later time, simply set the current time of day accordingly (e.g., to have the unit regenerate at 4:00 a.m.—two hours later—set the clock two hours earlier than the actual time of day).

**NOTE:** The Timer Locking Pin should always be horizontal (Figure 12) during operation.

### Hardness Setting

Move the jumper to the set of pins next to the word HARDNESS (Figure 14). Press the black TIME SET button until the hardness of the incoming water supply is displayed. The hardness range is from 1 to 99 grains per gallon.

To change water hardness stated in parts per million (PPM) to grains per gallon (GPG) use this formula:

$$\frac{\text{Parts per Million}}{17.1} = \text{Grains Per Gallon}$$

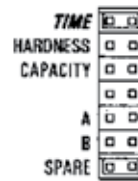

Figure 12

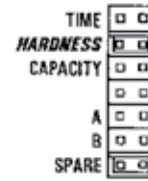

Figure 13



Figure 14

### Capacity Setting

Move the jumper to the set of pins next to the word CAPACITY (Figure 15). Press the black TIME SET button until the correct capacity value is displayed. The capacity range is 1 to 99 kilograins. Refer to the Suggested Salt Dial Settings table.

Return the jumper to the top set of pins next to the word TIME and replace the access door. The jumper must NOT be left on any pins other than the top pair next to the word TIME. Otherwise, the unit may show a blank display.

**NOTE:** A spare jumper is located on the bottom set of pins. In the event that the hardness or capacity setting must be changed, simply follow the appropriate steps described above.

### Calendar Override Setting

- Disconnect power.
- Place jumper on Pin A and reconnect power.
- Move jumper to Pin B. A zero will appear, indicating zero days of calendar override. All 460i controllers are preprogrammed in this manner at the manufacturer.
- Depress the black TIME SET button. The numbers will roll from "0" to "15." Release the switch at the desired number of days for the calendar override. For example, releasing the switch at "10" would program a 10-day calendar override.
- Disconnect power.
- Place jumper back on TIME and reconnect power.
- The calendar override program is maintained during power outages by the NOVRAM circuitry.
- To remove the calendar override, follow the same steps above and program back to "0."

# PROGRAMMING CONTINUED

## 460TC Control

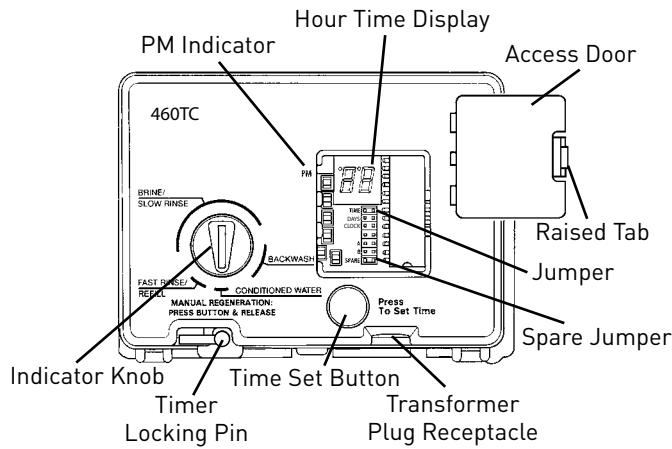

Figure 15

### Programming

Plug the wall-mount transformer into a functioning electrical outlet that is not controlled by a switch. Plug the transformer into the transformer plug receptacle on the control.

Open the access door by pushing the raised tab on the door toward the left while pulling the tab out (Figure 16).

### Time of Day Setting

With the jumper on the set of pins next to the word TIME (Figure 17), set the time of day to the closest hour by pressing the black TIME SET button. PM hours are indicated by a light next to the letters PM on the display window.

**NOTE:** The use of a small needle-nose pliers will aid in moving the jumper.

**NOTE:** The unit is factory set to regenerate at 2:00 a.m. If you prefer to have the unit regenerate at an earlier or later time, simply set the current time of day accordingly (e.g., to have the unit regenerate at 4:00 a.m.—two hours later—set the clock two hours earlier than the actual time of day).

**NOTE:** The Timer Locking Pin should always be horizontal (Figure 16) during operation.

### Days Setting

Move the jumper to the set of pins next to the word DAYS (Figure 18). Press the black TIME SET button until the desired number of days between regeneration is displayed. The range is from 1 to 30 days.



Figure 16



Figure 17



Figure 18

### Clock Setting

Move the jumper to the set of pins next to the word CLOCK (Figure 19). Press the black TIME SET button until the desired clock setting is displayed. The clock range is 0 to 1. Select 0 for the standard AM/PM clock or select 1 for a 24 hour clock.

Return the jumper to the top set of pins next to the word TIME and replace the access door. The jumper must NOT be left on any pins other than the top pair next to the word TIME. Otherwise, the unit may show a blank display.

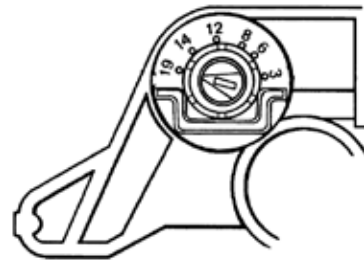

Figure 19

**NOTE:** A spare jumper is located on the bottom set of pins.

### Common Features

When using the 255 valve with the 440i or 460i controls, there are several features and procedures that are unique to the 400 series controls. They are as follows:

### Salt Dial Adjustment

Table 1 – Suggested Salt Dial Settings (Pounds of Salt) For Various Size Softeners

Capacity Setting (Kilograms)	0.5 FT <sup>3</sup>	0.75 FT <sup>3</sup>	1.0 FT <sup>3</sup>	1.25 FT <sup>3</sup>	1.5 FT <sup>3</sup>	1.75 FT <sup>3</sup>	2.0 FT <sup>3</sup>
12	4.5	—	—	—	—	—	—
16	9.0	5.5	—	—	—	—	—
20	—	8.5	6.0	—	—	—	—
24	—	14.0	8.5	7.0	—	—	—
30	—	—	15.0	11.0	9.0	—	—
32	—	—	18.5	12.5	10.0	9.0	—
35	—	—	—	16.0	12.0	10.0	9.0
40	—	—	—	11.5*	17.0	14.0	12.0
48	—	—	—	—	14.0*	10.5*	17.0
60	—	—	—	—	—	—	15.0*

\*This setting requires the use of "XS" (extra salt) cam and doubles the amount of the setting.

These models may be adjusted to produce maximum to minimum conditioning capacities by setting the salt dial, which controls the amount of salt used per regeneration. When desired, the minimum setting may be used on installations if the frequency of regeneration is increased to compensate for lower regenerated conditioning capacity. The installing dealer will set the unit for proper salt usage. Further adjustments are needed only if the hardness of the water supply changes or if water use changes dramatically. Capacity will need to be adjusted accordingly.

To adjust salt dosage, insert a small screwdriver into the white indicator knob and move pointer to proper salt setting (Figure 13).

**NOTE:** To convert the salt settings from English to metric, divide by 2.2 (e.g., 12 pounds ÷ 2.2 = 5.5 kg of salt).



## PROGRAMMING CONTINUED

### Guest Cycle (Manual Regeneration)

When abnormally high water usage exhausts your water conditioner's capacity ahead of schedule, an extra regeneration can be achieved. Depress the indicator knob on the 440i (Figure 11) with a wide-blade screwdriver and turn COUNTERCLOCKWISE to START to initiate a regeneration. For the 460i, simply depress the indicator knob (Figure 12). It will take a few minutes for regeneration to start. A normal regeneration will take approximately two hours.

## SERVICE AND MAINTENANCE

Inspect and clean brine tank and screen filter on end of brine pickup tube once a year or when sediment appears in the bottom of the brine tank.

Clean injector screen and injector once a year:

1. Unplug the wall-mount transformer.
2. Shut off water supply or put bypass valve(s) into bypass position.
3. Relieve system pressure by opening valve No. 5 (at rear) with a screwdriver.
4. Using a screwdriver, remove injector screen and injector cap (Figure 16).
5. Clean screen using a fine brush. Flush until clean.
6. Using a needle-nose pliers, pull injector straight out.
7. Flush water into the injector screen recess of the valve body to flush debris out through the injector recess.
8. Clean and flush the injector.
9. Lubricate the o-rings on the injector, injector cap and injector screen with silicone lubricant.
10. Reinstall the injector, injector cap and injector screen. See IMPORTANT note.
11. Plug the wall-mount transformer into outlet; reset time of day.
12. Slowly open water supply valve or return bypass valve(s) to the "not in bypass" position.

**IMPORTANT:** Do not overtighten the plastic cap. Seat the cap lightly into position. Overtightening may cause breakage of the plastic cap that may not be immediately evident.

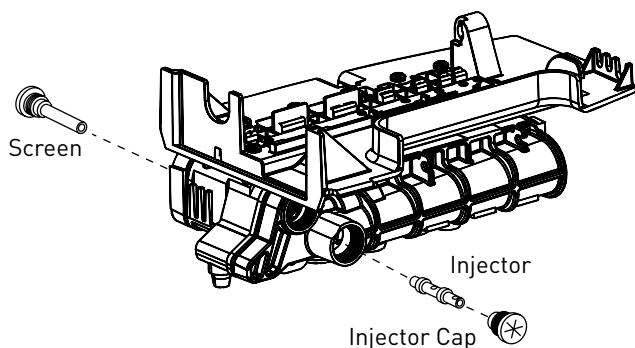

Figure 20

## Disinfection Of Water Conditioners

The materials of construction of the modern water conditioner will not support bacterial growth, nor will these materials contaminate a water supply. During normal use, a conditioner may become fouled with organic matter, or in some cases with bacteria from the water supply. This may result in an off-taste or odor in the water.

Some conditioners may need to be disinfected after installation and some conditioners will require periodic disinfection during their normal life.

Depending upon the conditions of use, the style of conditioner, the type of ion exchanger, and the disinfectant available, a choice can be made among the following methods.

### Sodium or Calcium Hypochlorite Application

These materials are satisfactory for use with polystyrene resins, synthetic gel zeolite, greensand and bentonites.

#### 5.25% Sodium Hypochlorite

These solutions are commonly known as household bleach. If stronger solutions are used, such as those sold for commercial laundries, adjust the dosage accordingly.

1. Dosage
  - g. Polystyrene resin; 1.2 fluid ounce (35.5 ml) per cubic foot.
  - h. Non-resinous exchangers; 0.8 fluid ounce (23.7 ml) per cubic foot.
2. Brine tank conditioners
  - a. Backwash the conditioner and add the required amount of hypochlorite solution to the well of the regenerant tank. The regenerant tank should have water in it to permit the solution to be carried into the conditioner.
  - b. Proceed with the normal regeneration.

#### Calcium Hypochlorite

Calcium hypochlorite, 70% available chlorine, is available in several forms including tablets and granules. These solid materials may be used directly without dissolving before use.

1. Dosage
  - a. Two grains (approximately 0.1 ounce [3 ml]) per cubic foot.
2. Regenerant tank conditioners
  - a. Backwash the conditioner and add the required amount of hypochlorite to the well of the regenerant tank. The regenerant tank should have water in it to permit the chlorine solution to be carried into the conditioner.
  - b. Proceed with the normal regeneration.

**255 VALVE & TANK ADAPTER MODULE**

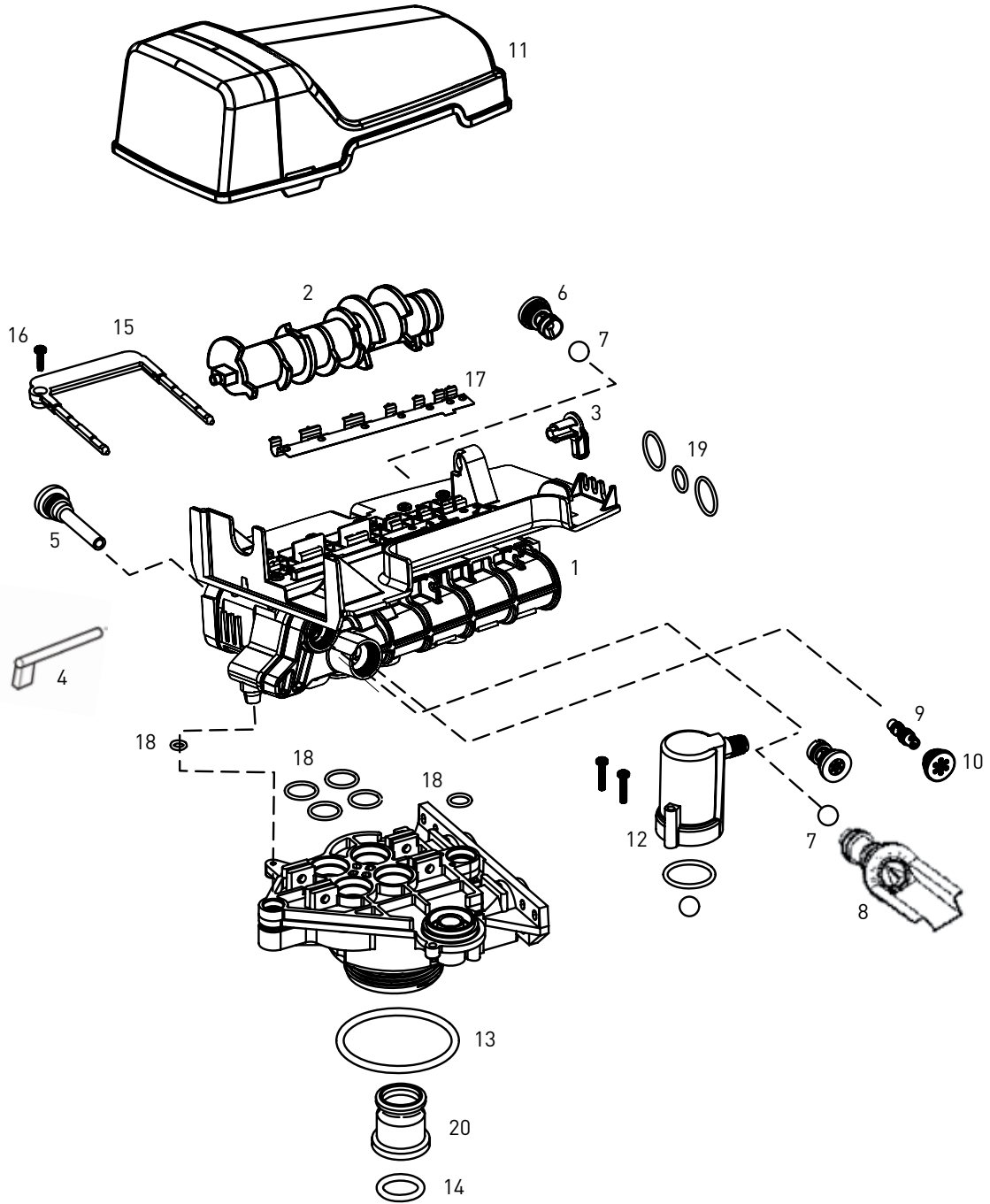

## 255 VALVE & TANK ADAPTER MODULE

### CONTINUED

Item No.	QTY	Part No.	Description
1	1	1000232	Valve Assembly, w/o Flow Controls
2	1		Camshaft:
		1031950	Standard, One-Piece
		1033024	Standard, Segmented
		1033025	Extra Salt, Segmented
		1033026	Long Rinse, Segmented
		1032969	Water Saver, Segmented
3	1	3019873	Lever, Locking Cam
4	1	1031391	Timer Locking Pin
5	1	1000226	Screen/Cap Assembly w/O-Ring
6	1		Drain Control Assembly w/O-Rings:
		1000209	No. 7 (1.2 gpm; 4.5 Lpm)
		1000210	No. 8 (1.6 gpm; 6.1 Lpm)
		1000211	No. 9 (2.0 gpm; 7.6 Lpm)
		1000212	No. 10 (2.5 gpm; 9.5 Lpm)
		1000213	No. 12 (3.5 gpm; 13.2 Lpm)
		1000214	No. 13 (4.1 gpm; 15.5 Lpm)**
		1000215	No. 14 (4.8 gpm; 18.2 Lpm)**
7	2	1030502	Ball, Flow control
8	1		Brine Refill Control:
		1034261	1 to 10 lbs Salt
		1034263	3 to 19 lbs Salt
9	1		Injector Assembly with O-Rings:
		1032970	"A" Injector - White
		1032971	"B" Injector - Blue
		1032972	"C" Injector - Red
10	1	1000269	Injector Cap with O-Ring
11	1	3019870	i-Lid Cover
12	1	1032416	Air Check Kit
13	1	1010154	O-Ring EPDM
14	1	1232370	O-Ring EP
15	1		Locking Bar:
		1031402	English Language
		1031403	French Language
		1031404	German Language
		1031405	Italian Language
		1031406	Japanese Language
		1031407	Spanish Language
16	1	1006093	Screw, No. 8 x 9/16 inch
17	1	1235341	Spring, one pc 255

Item No.	QTY	Part No.	Description
<b>Kits</b>			
18		1001404	O-Ring Group: Tank Adapter, 1010117 (1), 1010407 (1), 1010410 (4)
19		1040459	O-Ring Group: Piping Boss 1010431 (1), 1010411 (2)
20		1041010	13/16 inch Rubber Insert (Optional)

#### Valve Discs

\* ..... 1000250 ..... Standard

\*Not Shown

\*\*Flow control does not use Flow Control Ball (1030502).

# 255 SERIES

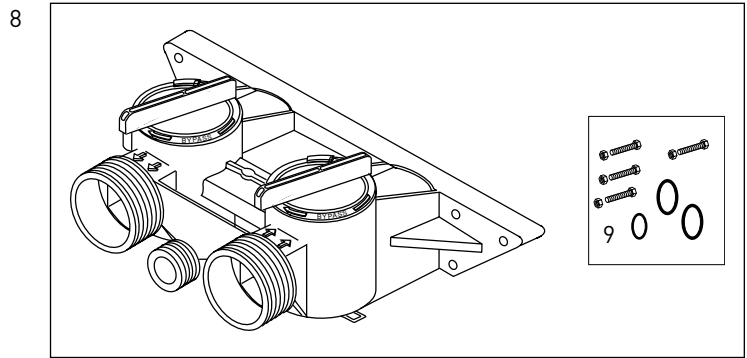
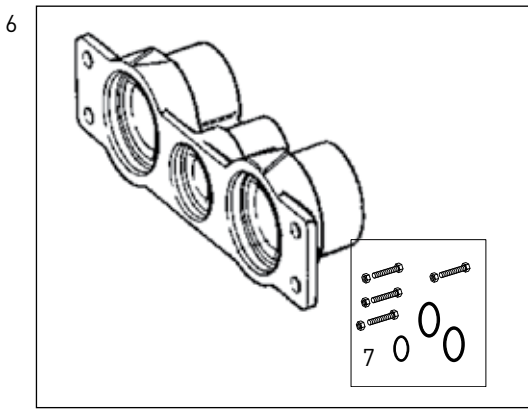
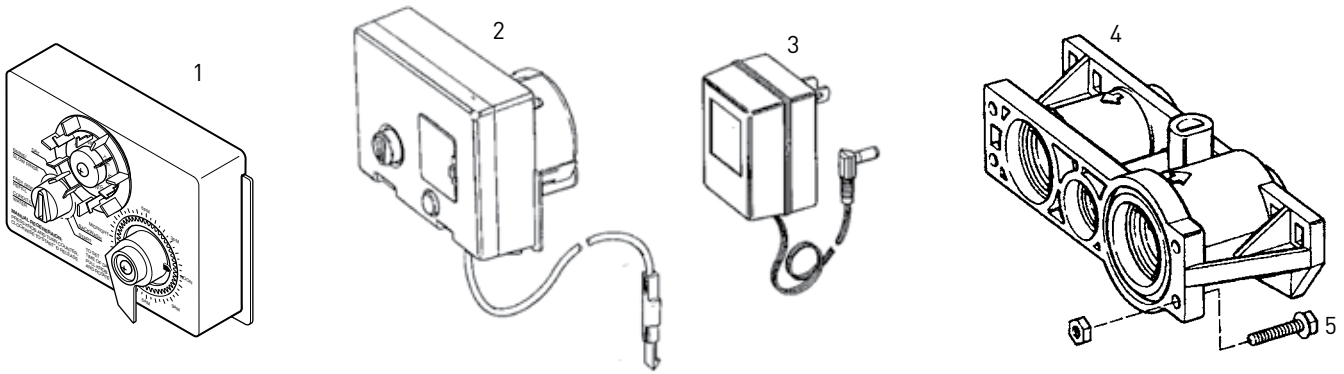

**NOTE:** Do not use pipe joint compound when threading pipe into the Noryl piping boss. Use only plumber pipe tape. Do not overtighten pipe into Noryl piping boss.

## 255 SERIES CONTINUED

Item No.	QTY	Part No.	Description
1	1		440i Assembly (obsolete)
2	1		460i/460TC Assembly
3	1		Transformer:
		1000810	Japanese
		1000811	North American
		1000812	Australian
		1000813	British
		1000814	European
*	1	1030234	Transformer Extension Cord 15 foot (4.5 m)
*	1	1007776	Jumper

### Meter Adapter

4	1	1032350	Kit, Meter Adapter
5	1	1032351	Meter Install Kit

### Piping Boss

6	1		Piping Boss Kit (includes Hardware):
		3023763	3/4-inch NPT, S.S. 3/8-inch NPT Drain
		3023749	1-inch NPT, S.S. 1/2-inch NPT Drain
		3023761	3/4-inch BSPT, S.S. 3/8-inch BSPT Drain
		3023747	1-inch BSPT, S.S. 1/2-inch BSPT Drain
		1040279	3/4-inch NPT, Noryl 1/2-inch NPT Drain
		1040280	1-inch NPT, Noryl 1/2-inch NPT Drain
		1040283	3/4-inch BSPT, Noryl 1/2- inch BSPT Drain
		1040284	1-inch BSPT, Noryl 1/2-inch BSPT Drain
7	1	1040339	Piping Boss installation Kit

### Bypass Valve

8	1	1040769	Bypass Body Assembly with Install Kit
9	1	1040524	Bypass Installation Kit

### Item No. QTY Part No. Description

#### Tube Adapter Kits

*	1	1001606	3/4-inch Copper Tube Adapter Kit
*	1	1001670	1-inch Copper Tube Adapter Kit
*	1	1041210	1-1/4 inch Copper Tube Adapter Kit
*	1	1040547	90 degree Elbow Adapter Kit
*	1	1001608	22 mm Copper Tube Adapter Kit
*	1	1001613	3/4-inch CPVC Tube Adapter Kit
*	1	1001614	1-inch CPVC Tube Adapter Kit
*	1	1001615	25 mm CPVC Tube Adapter Kit
*	1	1001769	3/4-inch NPT Plastic Pipe Adapter Kit
*	1	1001603	1-inch NPT Plastic Pipe Adapter Kit
*	1	1001604	3/4-inch BSPT Plastic Pipe Adapter Kit
*	1	1001605	1-inch BSPT Plastic Pipe Adapter Kit
*	1	3023824	3/4-inch BSPT S.S. Pipe Adapter Kit
*	1	3023828	1-inch NPT S.S. Pipe Adapter Kit
*	1	3023807	1-inch BSPT S.S. Pipe Adapter Kit

\*Not Shown

## **TROUBLESHOOTING**

The technology upon which the Series 255 control is based is well established and proven in service over many years. However, should a problem or question arise regarding the operation of the system, the control can be very easily serviced. The control module can be quickly replaced or adjustments can be made at the installation. We recommend that you contact your local professional water treatment dealer for most concerns. For parts mentioned, refer to exploded views in the Replacement Parts section of this manual.

**IMPORTANT:** Service procedures that require the water pressure to be removed from the system are marked with a ! after the possible cause. Refer to Preventative Maintenance section for instructions.

### **Valve Troubleshooting**

<b>Problem</b>	<b>Cause</b>	<b>Correction</b>
Brine tank overflow.	Uncontrolled brine refill flow rate.	Remove brine control to clean ball and seat.
	Air leak in brine line to air check.	Check all connections in brine line for leaks. Refer to instructions.
	Drain control clogged with resin or other debris.	Clean drain control.
Flowing or dripping water at drain or brine line after regeneration.	Valve stem return spring weak.	Replace spring. (Contact dealer.)
Hard water leakage after regeneration.	Improper regeneration.	Repeat regeneration after making certain correct salt dosage was set.
	Leaking of external bypass valve.	Replace bypass valve. (Contact dealer.)
	O-ring around riser pipe damaged.	Replace o-ring. (Contact dealer.)
Control will not draw brine.	Low water pressure.	Make correct setting according to instructions.
	Restricted drain line.	Remove restriction.
	Injector plugged !	Clean injector and screen.
	Injector defective !	Replace injector and cap. (Contact dealer.)
	Valve disc 2 and/or 3 not closed.	Remove foreign matter from disc and check disc for closing by pushing in on stem. Replace if needed. (Contact dealer.)
Air check valve prematurely closed.	Put control momentarily into brine refill. Replace or repair air check if needed. (Contact dealer.)	

## TROUBLESHOOTING *CONTINUED*

### 255/440i Troubleshooting

Problem	Cause	Correction
Control will not draw brine.	Low water pressure.	Set pump to maintain 20 psi at softener.
	Restricted drain line.	Change drain to remove restriction.
	Injector plugged.	Clean injector and screen.
	Injector defective.	Replace injector. (Contact dealer.)
	Air check valve closes prematurely.	Put control momentarily into brine/slow rinse. Replace or repair air check if needed. (Contact dealer.)
System using more or less salt than regenerant setting.	Foreign matter in controller causing incorrect flow rates.	Remove brine control and flush out foreign matter. Manually position control to brine/slow rinse to clean controller (after so doing position control to "purge" to remove brine from tank).
Intermittent or irregular brine draw.	Low water pressure.	Set pump to maintain 20 psi at softener.
	Defective injector.	Replace injector. (Contact dealer.)
No conditioned water after regeneration.	No salt in brine tank.	Add salt to brine tank.
	Injector plugged.	Clean injector and screen.
	Air check valve closes prematurely.	Put control momentarily into brine/slow rinse. Replace or repair air check if needed. (Contact dealer.)
Control backwashes or purges at excessively low or high rate.	Incorrect drain controller used.	Replace with correct size controller. (Contact dealer.)
	Foreign matter affecting controller operation.	Remove drain controller and clean ball and seat.

### 255/460i/460TC Troubleshooting

Problem	Cause	Correction
No water flow display when water is flowing.	Bypass valve in bypass.	Shift bypass valve to not-in-bypass position.
	Meter probe disconnected or not fully connected to meter housing.	Fully insert probe into meter housing.
	Restricted meter turbine rotation due to foreign material in meter !	Remove meter housing, free up turbine and flush with clean water. Turbine should spin freely. If not, replace meter. (Contact dealer.)
	Defective meter probe.	Replace meter cable (no meter cable for the 460TC) (Contact dealer.)
Continuous regeneration. Camshaft does not stop at the end of regeneration.	Misaligned optical sensor.	Replace optical sensor (no sensor for the 460TC). (Contact dealer.)
Run out of soft water between regenerations.	Improper regeneration.	Repeat regeneration, making certain that correct salt dosage is used.
	Incorrect salt setting.	Set salt control to proper level. See salt setting chart.
	Incorrect hardness or capacity settings.	Set to correct values. See Programming section.
	Water hardness has increased.	Set hardness or days to new value. See Programming section.
	Restricted meter turbine rotation due to foreign material in meter !	Remove meter housing, free up turbine and flush with clean water. Turbine should spin freely; if not, replace meter. (Contact dealer.)

# FLOW DIAGRAMS

## 255 Valve

### Service Position

- Hard Water
- Soft Water

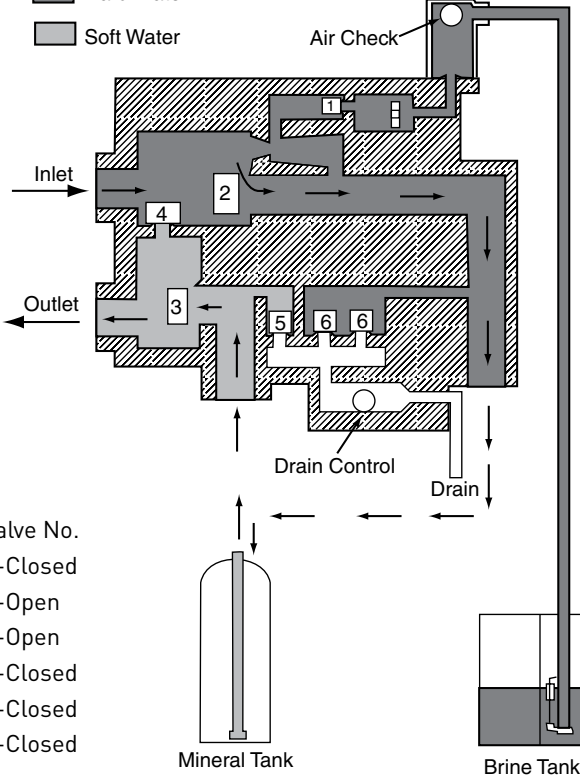

### Brining Position

- Hard Water
- Soft Water

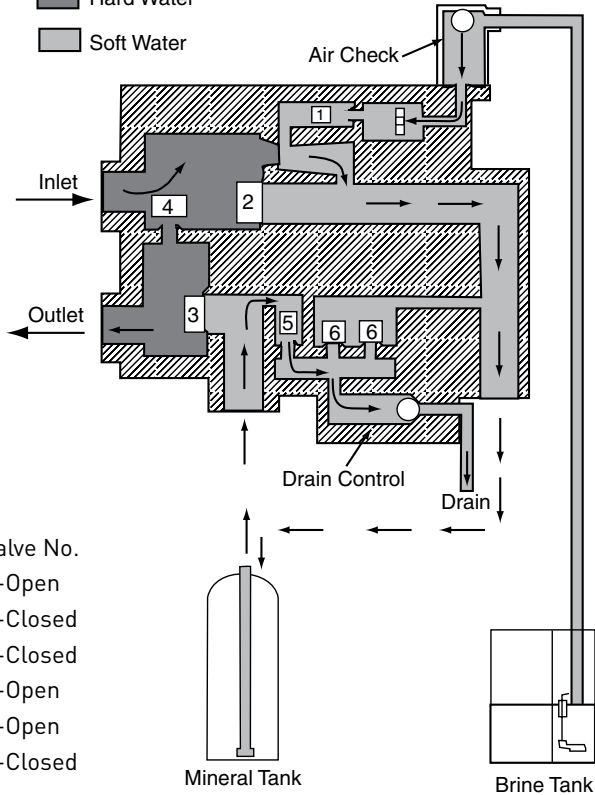

### Backwash Position

- Hard Water
- Soft Water

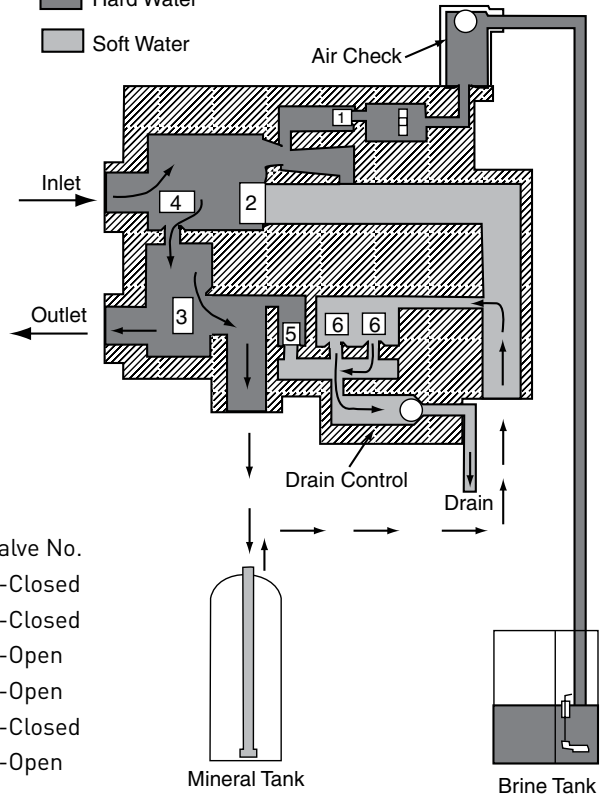

### Slow Rinse Position

- Hard Water
- Soft Water

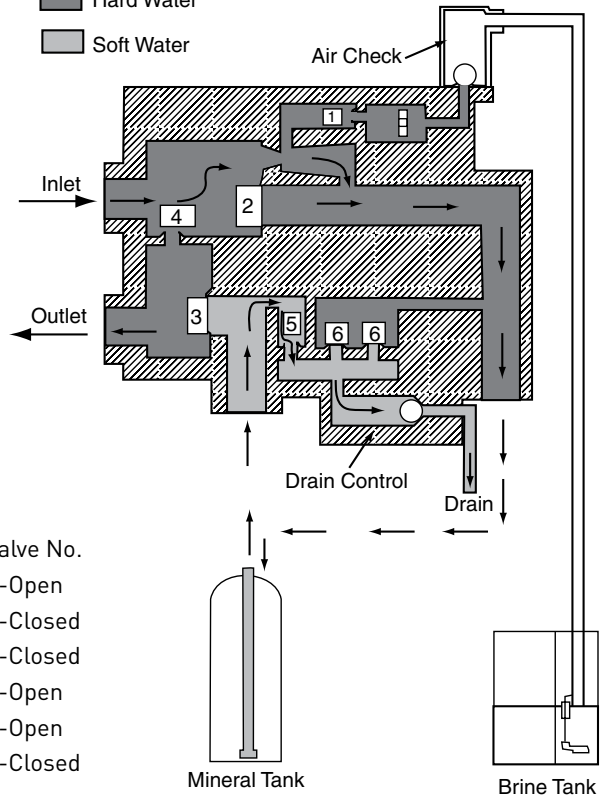



# FLOW DIAGRAMS CONTINUED

## Repressurize Position

- Hard Water
- Soft Water

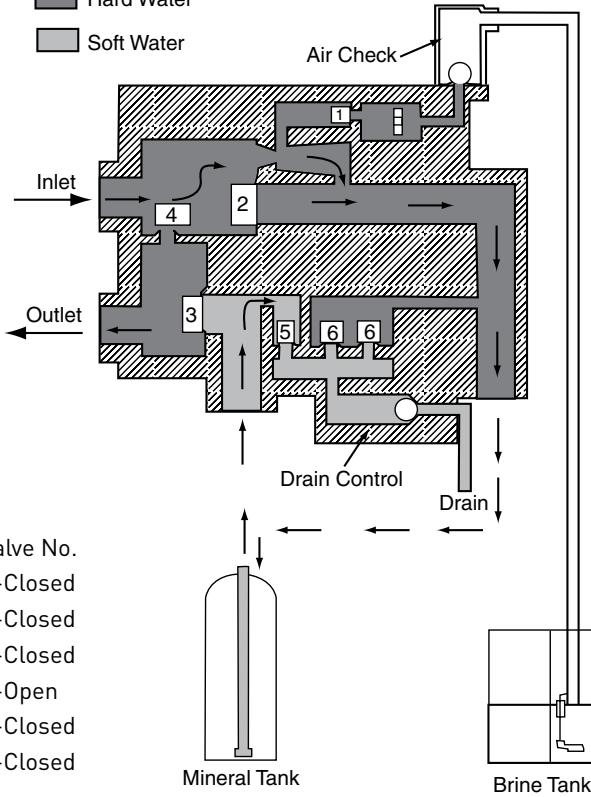

- Valve No.
- 1-Closed
  - 2-Closed
  - 3-Closed
  - 4-Open
  - 5-Closed
  - 6-Closed

## Fast Rinse Position

- Hard Water
- Soft Water

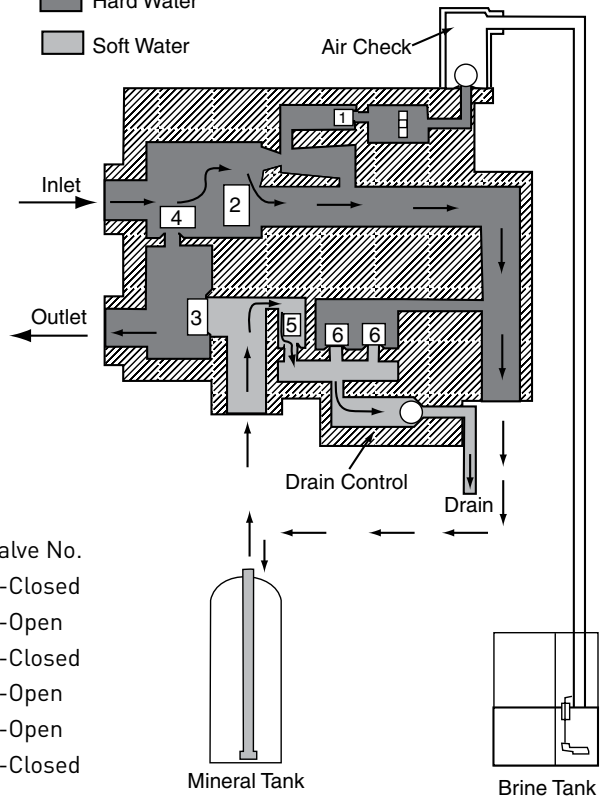

- Valve No.
- 1-Closed
  - 2-Open
  - 3-Closed
  - 4-Open
  - 5-Open
  - 6-Closed

## Brine Refill Position

- Hard Water
- Soft Water

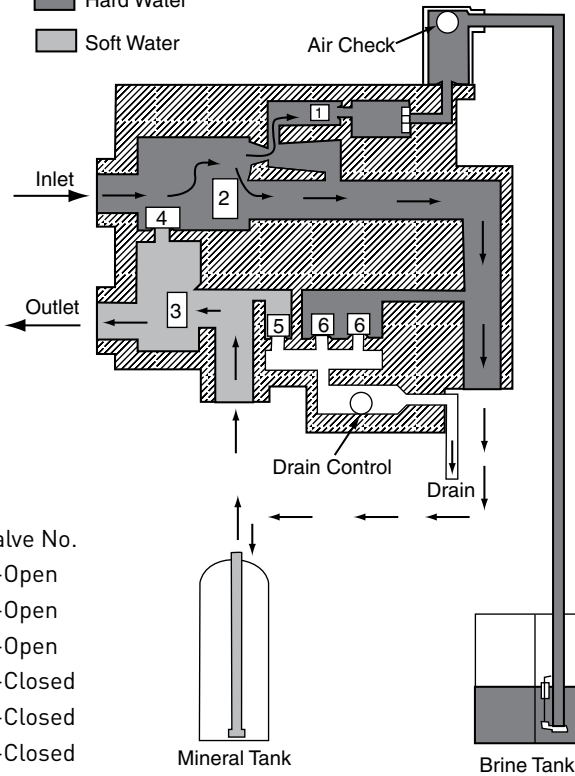

- Valve No.
- 1-Open
  - 2-Open
  - 3-Open
  - 4-Closed
  - 5-Closed
  - 6-Closed

## FLOW DATA CHARTS

### 255 Valve Flow Data

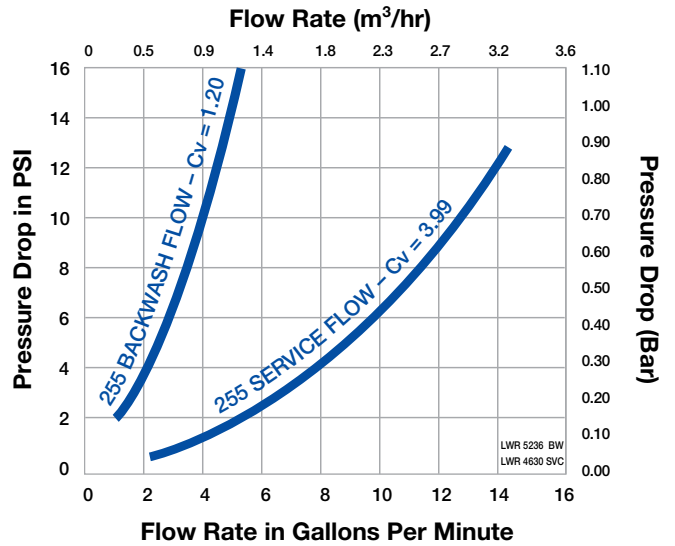

**Injector Performance Graphs**

**Injector "F" (Peach)**  
For 7-inch Tanks

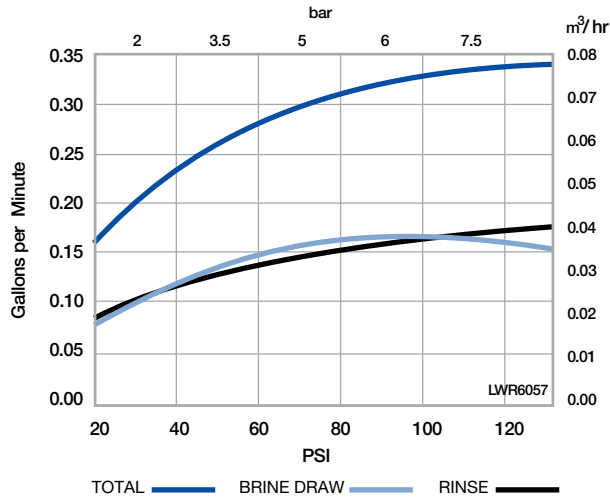

**Injector "J" (Light Blue)**  
For 10-inch Tanks

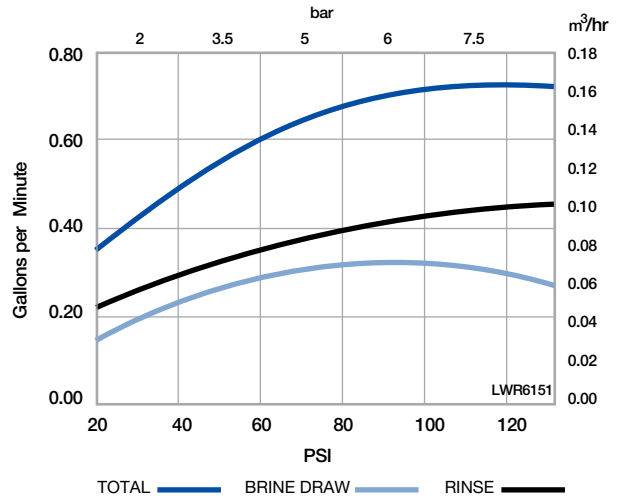

**Injector "G" (Tan)**  
For 8-inch Tanks

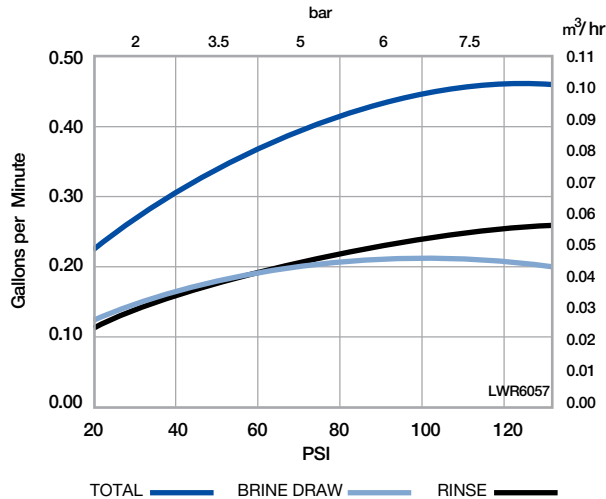

**Injector "K" (Pink)**  
For 12-inch Tanks

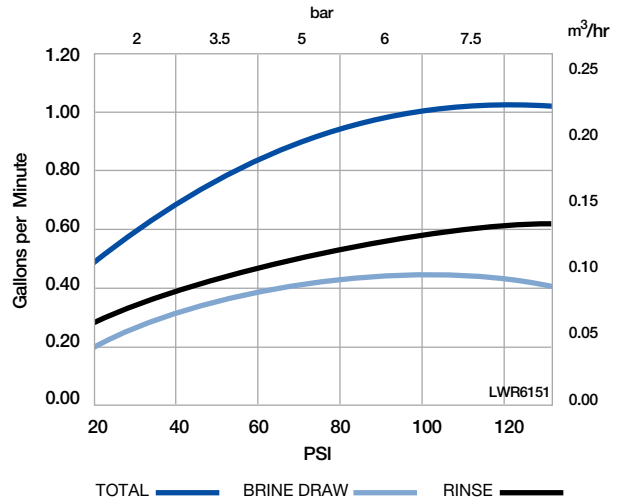

**Injector "H" (Light Purple)**  
For 9-inch Tanks

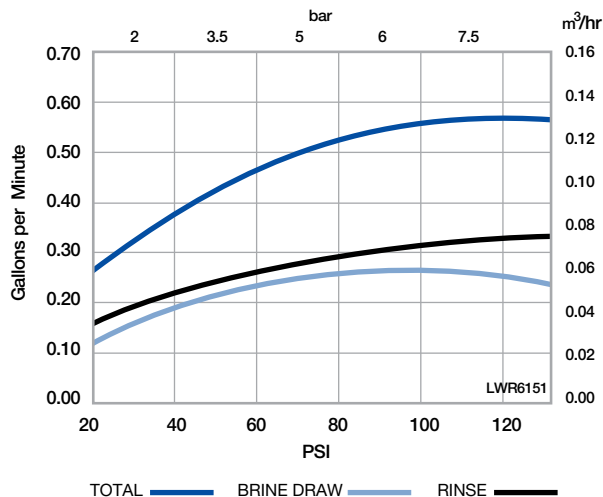

**Injector "L" (Orange)**  
For 13- and 14-inch Tanks

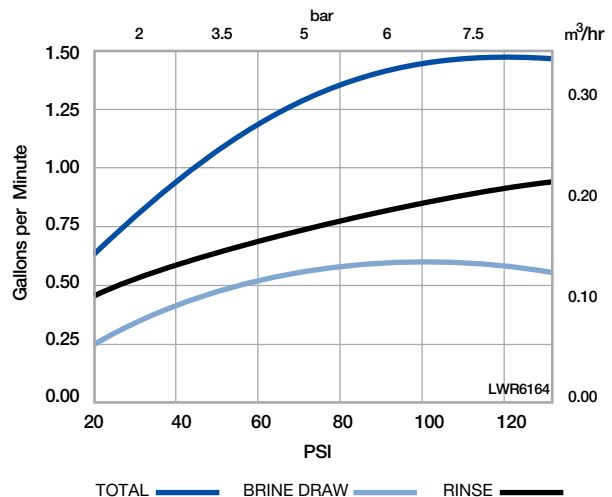



For Autotrol® Product Warranties visit:  
Autotrol® para las garantías de los productos visite: } [www.pentairaqua.com/pro](http://www.pentairaqua.com/pro)  
Pour Autotrol® garanties produit visitez le site :



**FILTRATION & PROCESS**

5730 NORTH GLEN PARK ROAD, MILWAUKEE, WI 53209

P: 262.238.4400 | [WWW.PENTAIRAQUA.COM](http://WWW.PENTAIRAQUA.COM) | CUSTOMER CARE: 800.279.9404 | [tech-support@pentair.com](mailto:tech-support@pentair.com)

All Pentair trademarks and logos are owned by Pentair, Inc. or its affiliates. All other registered and unregistered trademarks and logos are the property of their respective owners. Because we are continuously improving our products and services, Pentair reserves the right to change specifications without prior notice. Pentair is an equal opportunity employer.

1018075 REV R FE14 © 2014 Pentair Residential Filtration, LLC All Rights Reserved.