

MAXI WATER BOOST SYSTEM

System Part Number:
804-036 VAC 1/2" (13mm) Barb Fittings
804-038 VAC 3/8" (10mm) Barb Fittings



FEATURES • BENEFITS

- ◆ Provides consistent water pressure to fountain and beverage equipment to provide quality beverages
- ◆ Replaceable bladder helps extend tank life and allows for easy maintenance
- ◆ Self-priming pump can run dry without damage
- ◆ Eliminates pulsation at dispenser valve resulting in more accurate brix ratio and maximum syrup utilization
- ◆ Low profile allows for quick and easy under counter installation
- ◆ Rigid stainless steel tanks for reliable performance

APPLICATIONS

- ◆ Fountain beverages
- ◆ Coffee brewers
- ◆ Drinking water

INSTALLATION TIPS

- ◆ Must be installed BEFORE water filtration.
- ◆ Charge tank pre-charge at the time of installation is 50 psi (3.45 bar).
- ◆ Check the pre-charge each service visit to ensure optimum performance.
- ◆ Do not charge accumulator tank with CO₂.
- ◆ Use NSF listed high-pressure braided tubing for inlet/outlet port (not included).

MAXI WATER BOOST SYSTEM

804-036, 804-038

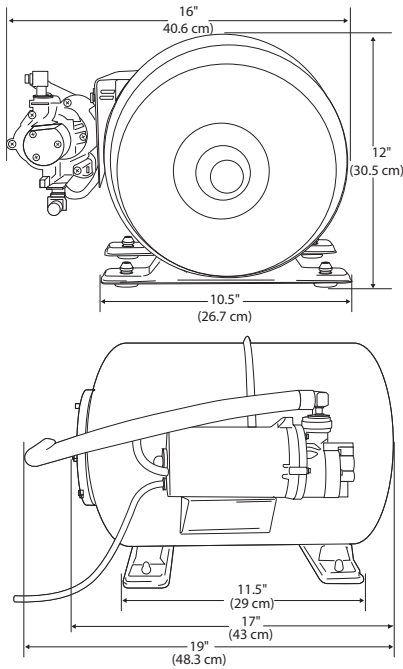

SPECIFICATIONS

- ◆ **Booster Pump**
Shurflo 90 psi 230 VAC 8000 series corded pump (NSF, UL, CUL listed)
- ◆ **Accumulator Tank**
6 gallon (22.7 L) SS and bladder (NSF listed)
- ◆ **Ports**
804-036: 1/2" (13 mm) barb
804-038: 3/8" (10 mm) barb inlet/outlet
- ◆ **Pre-charge**
Shipped without pre-charge.
50 psi (3.45 bar) recommended for most beverage applications.
- ◆ **Draw Down Volume**
3.1 gallons @ 50 psi
(11.7 L @ 3.4 bar)
- ◆ **Dimensions**
12" H x 19" W x 16" D
(30.5 x 48.3 x 40.6 cm)
- ◆ **Electrical**
230 Vac / 50-60 Hz
- ◆ **Operating Pressure**
117 psi (8 bar)
- ◆ **Water Temperature**
34 - 120°F (1.1 - 4.9°C)
- ◆ **Weight**
18 lbs (8.1 kgs) empty

REPLACEMENT PARTS

Description	Part No
Replacement Bladder	94-697-00

For Pentair Product Warranties visit:
<http://pentair.com/assets/foodservice-warranty>

Since the conditions under which our products may be used are beyond our control, we cannot accept any liability with respect to the improper installation, application and/or use of our products.



1040 Muirfield Drive | Hanover Park, IL 60133 | 800.942.1153 (US Only) 630.307.3000 Main | cseverpure@pentair.com | foodservice.pentair.com

All indicated Pentair trademarks and logos are property of Pentair. Third party registered and unregistered trademarks and logos are the property of their respective owners.

©2023 Pentair. All rights reserved.

804-036/038 AU23